

LoadLifter 5000™ SERIES



Installation Guide



Ford F-250/F-350 SRW/DRW 2WD



Watch the video

Info on Table of Contents page

Kits 57397 | 88397

For maximum effectiveness and safety, please read these instructions completely before proceeding with installation.

Failure to read these instructions can result in an incorrect installation.

Protect your Air Lift Purchase by Completing your Warranty Registration



Thank you for purchasing an Air Lift load support product!

Take a photo of your sales receipt and then scan the QR code to complete your online warranty registration.

TABLE OF CONTENTS

2 System Overview

3 Hardware and Tools

4 Introduction

Notation Explanation

Identifying the Differences Between Kits

5 Installing the System

Prepare the Vehicle

Side Brace Installation

Air Spring and Bracket Assembly

Attaching the Assemblies to the Frame

Lower Bracket Attachment

Final Steps

11 Installing the Air Lines

Installing Nylon Air Lines

Installing the Heat Shield

13 Before Operating

Installation Checklist

Maintenance and Use Guidelines

16 Limited Warranty and Return Policy

Video-enhanced installation guides

Visit airliftcompany.com/workshop/category/install-videos to access our installation video archive*.

System Overview

Driver side shown

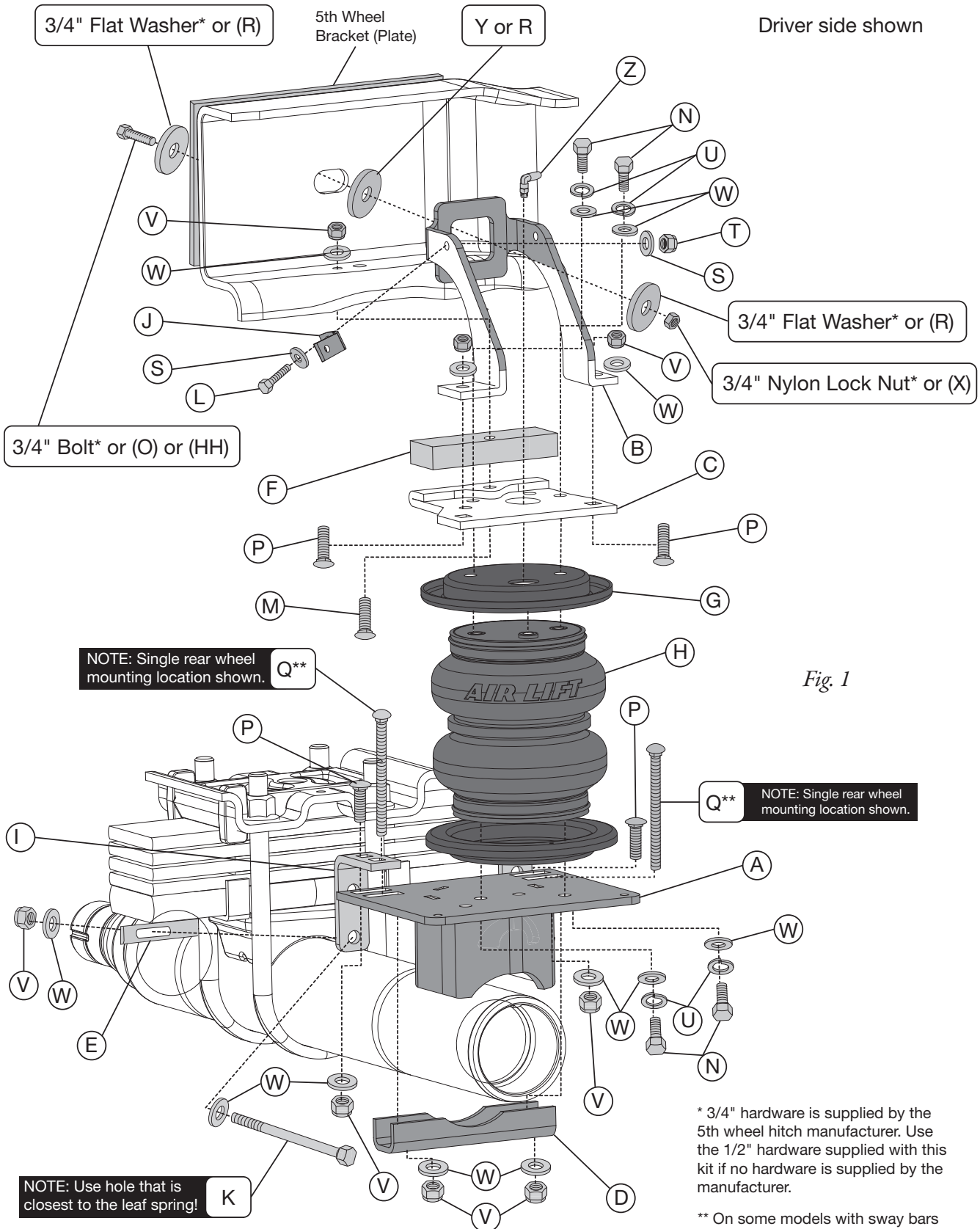

Fig. 1

Hardware and Tools

Common Parts Included in Both Kits

Item	Part#	Description	Qty
A	03991	Lower Bracket	2
B	07996	Upper Brace	2
C	07997	Upper Bracket	2
D	01531	Clamp Bar	2
E	10861	Spring Clamp Bar	2
F	13966	Spacer	2
I	10880	Four Hole Locating Bracket	4
J	10886	"L" Bracket	1
K	17110	3/8"-16 x 5 1/2" Hex Head Cap Screw	4
L	17135	1/4"-20 x 1" Hex Cap Screw	1
M	17141	3/8"-16 x 2 1/2" Carriage Bolt	2
N	17203	3/8"-24 x 7/8" Hex cap screw	4
O	17271	1/2"-13 x 3" Hex Cap Screw	2
P	17361	3/8"-16 x 1 1/4" Carriage Bolt	8
Q	17387	3/8"-16 x 10" Carriage Bolt	4
R	18207	1/2" Thick Flat Washer	6
S	18419	Flat Washer #12	2
T	18425	1/4"-20 Nylon Lock Nut	1
U	18427	3/8" Lock Washer	8
V	18435	3/8"-16 Nylon Lock Nut	18
W	18444	3/8" Flat Washer	34
X	18460	1/2"-13 Nylon Lock Nut	2
Y	18556	3/4" Flat Washer	2
Z	21837	1/8" MNPT-1/4" Swivel Elbow Fitting	2
AA*	10466	Zip Ties	6
BB*	18411	5/16" Lock Washer	2
CC*	21230	Valve Caps	2
DD*	21233	5/16" Hex Nut	2
EE*	21234	Rubber Washer	2
FF*	20086	Air Line Assembly	1
GG*	34924	Heat Shield Kit	1
HH	17208	1/2"-13 x 2" Hex Head Cap Screw	2

* These parts are not shown in the System Overview (Fig. 1).

Unique Parts in Each Kit

LoadLifter 5000™ KIT 57397

Item	Part#	Description	Qty
G	11951	Zinc-coated Roll Plate	4
H	58437	Air Spring	2

LoadLifter 5000™ ULTIMATE KIT 88397

Item	Part#	Description	Qty
G	11967	Black Powder Coated Roll Plate	4
H	58496	Air Spring with Integrated Jounce Bumper	2

TOOLS NEEDED

Description	Qty
7/16" and 9/16" Open-end or Box Wrenches	2
Adjustable Wrench	1
Ratchet with 3/8", 9/16", & 1/2" Deep Well Sockets	1
5/16" Drill Bits (very sharp)	1
DIE Grinder	1
Hacksaw	1
Heavy Duty Drill	1
Torque Wrench	1
Standard, Metric and SAE Sockets and Wrenches	1
Hose Cutter, Razor Blade, or Sharp Knife	1
Hoist or Floor Jacks	1
Safety Stands	2
Safety Glasses	1
Air Compressor or Compressed Air Source	1
Spray Bottle with Dish Soap/Water Solution	1



Missing or damaged parts? Call Air Lift customer service at (800) 248-0892 for a replacement part.

Introduction

The purpose of this publication is to assist with the installation and maintenance of the LoadLifter 5000 series air spring kits. All LoadLifter 5000 series kits utilize sturdy, reinforced, commercial-grade single or double, depending on the kit, convolute bellows.

The air springs are manufactured like a tire with layers of rubber and cords that control growth. LoadLifter 5000 kits provide up to 5,000 pounds (2,268kg) of load-leveling support with air adjustability from 5-100 PSI (.34-7BAR).

It is important to read and understand the entire installation guide before beginning installation or performing any maintenance, service or repair.

NOTATION EXPLANATION

Hazard notations appear in various locations in this publication. Information which is highlighted by one of these notations must be observed to help minimize risk of personal injury or possible improper installation which may render the vehicle unsafe. Notes are used to help emphasize areas of procedural importance and provide helpful suggestions. The following definitions explain the use of these notations as they appear throughout this guide.



DANGER

INDICATES IMMEDIATE HAZARDS WHICH WILL RESULT IN SEVERE PERSONAL INJURY OR DEATH.



WARNING

INDICATES HAZARDS OR UNSAFE PRACTICES WHICH COULD RESULT IN SEVERE PERSONAL INJURY OR DEATH.



CAUTION

INDICATES HAZARDS OR UNSAFE PRACTICES WHICH COULD RESULT IN DAMAGE TO THE VEHICLE OR MINOR PERSONAL INJURY.



Used to help emphasize areas of procedural importance and provide helpful suggestions.

IDENTIFYING THE DIFFERENCES BETWEEN KITS

Should you need to contact Air Lift customer service, you will need to know which kit you are inquiring about: standard LoadLifter 5000 or LoadLifter 5000 Ultimate. The kits are easily identifiable by looking at the roll plates and air lines.

- ❑ Standard **LoadLifter 5000** — Zinc-plated steel roll plates and black nylon air lines.
- ❑ **LoadLifter 5000 Ultimate** — Black powder-coated roll plates and black nylon air lines.



LoadLifter 5000
silver zinc-plated steel roll plate



LoadLifter 5000
nylon air line



LoadLifter 5000 Ultimate
black powder-coated roll plate



LoadLifter 5000 Ultimate
nylon air line

Installing the System

PREPARE THE VEHICLE

1. Jack up the rear of the vehicle or raise on a hoist.
Support the axle with safety stands (Fig. 2). Lower the axle or raise the body of the vehicle until the springs are completely extended.
2. Remove the jounce bumpers from under the frame, over the axle.
3. If necessary, disconnect the wiring harness from the driver side frame rail to gain clearance for the upper bracket.
4. For all dual rear wheel vehicles (DRW) it will be necessary to remove the sway bar strap and bolts holding the sway bar to the axle. Retain for later reinstallation.
5. If you have a fifth wheel hitch already installed, it will be necessary to remove the 3/4" hardware that bolts the side bracket to the outside of the frame above the axle (Fig. 1).

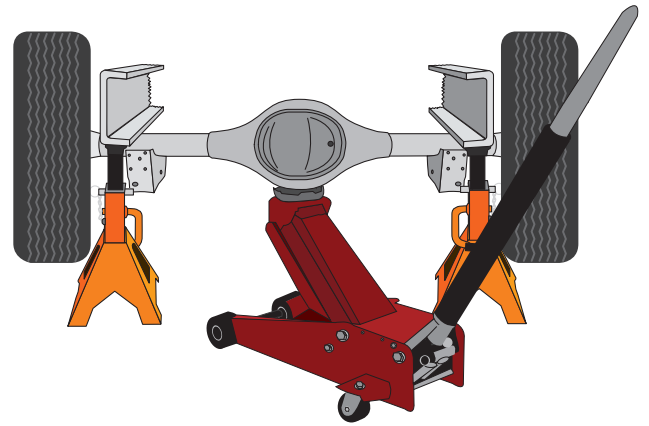

Fig. 2

NOTE

Some hitch models have a spacer between the bracket and the frame rail. Be sure to reinstall the spacer when attaching the upper bracket.

If your model truck has emissions lines running along the inside of the frame rail (Fig. 3), it will be necessary to relocate those lines as follows. Follow the directions in the section, "Attaching the Assemblies to the Frame" for reattaching these lines.

- Carefully push the line holder out of the frame above the axle. Try to minimize damage because it will be reused later. It may also be helpful to remove any holders forward or rearward of the axle to aid in positioning the lines once the upper bracket has been installed (Fig. 3).

- Attach the L-bracket (J) to the back frame brace using the 1/4" bolt (L), flat washers (S) and nylon lock nut (T) supplied (Fig. 1). This L-bracket will eventually be used to attach the previously removed emissions line. Do not attach the line holder to it at this time.

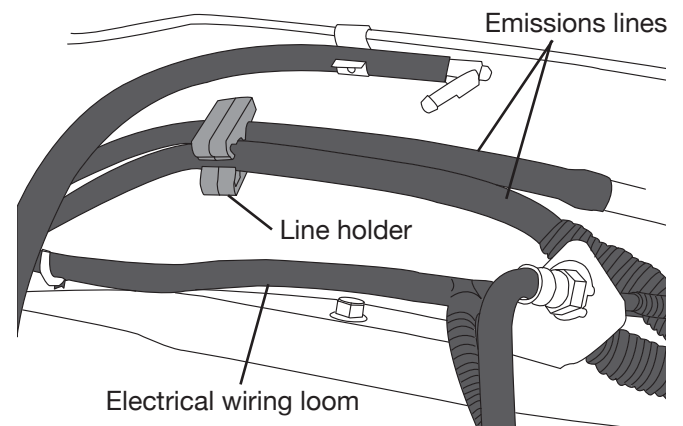

Fig. 3

SIDE BRACE INSTALLATION

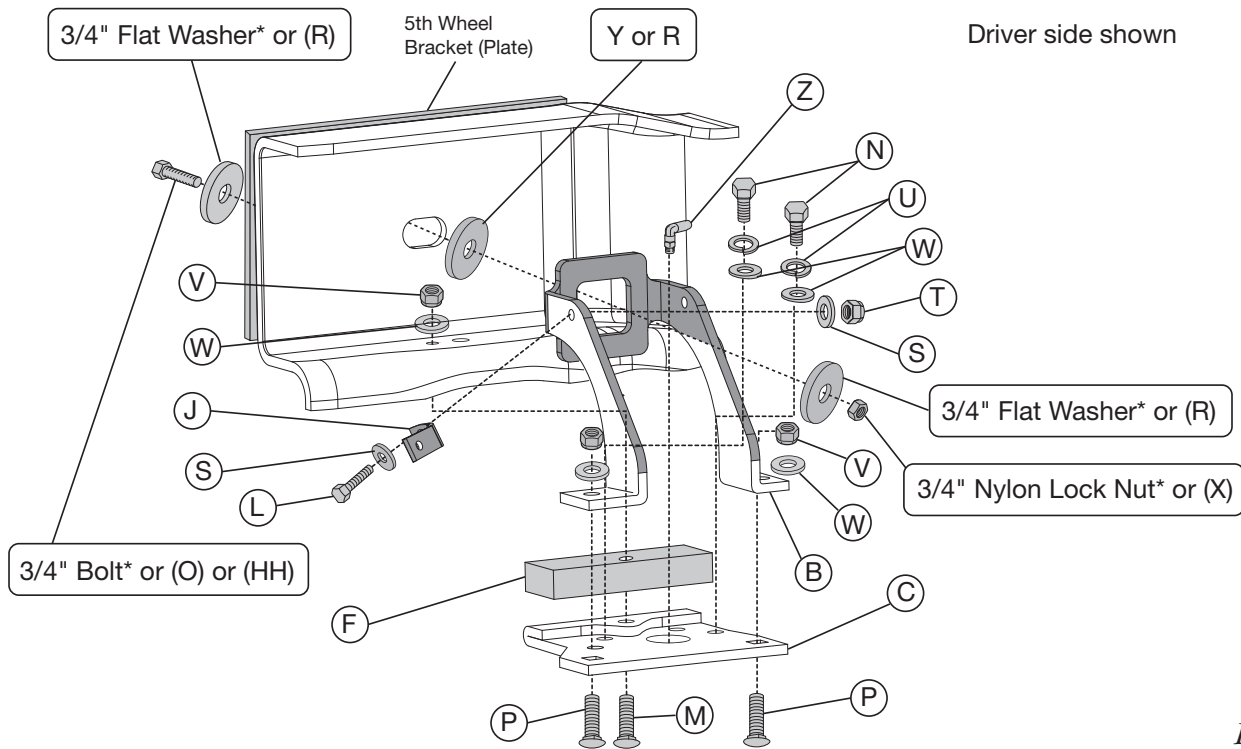

Fig. 4

1. Set the upper brace (B) into the driver and passenger side frame (Fig. 4).

If you have no fifth wheel hitch or a hitch that does not have a plate running along side the full length of the frame (these will have an “L” bracket forward and behind the axle leaving the middle frame open) use the 1/2”-13 x 2.00” hex cap screw (HH) with a flat washer (R) through the slot in the side of the frame, then through another flat washer (R) and finally through the upper brace. Cap with a flat washer (R) and a 1/2”-13 nylon lock nut (X) (Fig. 5). Leave loose at this time.

OR

If you have an aftermarket fifth wheel hitch that has a bracket (plate) running along side of the frame and it used this slot to secure the bracket to the frame with existing hardware, install the existing hardware previously removed in the “getting started section” from the fifth wheel installation for securing the brace (Fig. 4). Make sure to install the large 3/4” flat washer (Y) between the brace and frame (Figs. 1 and 4). Leave loose at this time.

OR

If you have an aftermarket fifth wheel hitch that has a bracket (plate) running along side of the frame and it does not have any attaching hardware on the side where the slot in the frame is, it will be necessary to drill a 1/2” hole through the plate using the slot in the frame as a template. Drill the hole as far back in the slot as you can.

NOTE

It may be necessary to mark and remove the bracket (plate) from the side of the frame in order to drill the hole correctly. Re-attach once the hole is drilled.

Insert a 1/2”-13 x 3” hex cap screw (O) with a flat washer (R) through the fifth wheel plate previously drilled, the frame, then through another flat washer (R) and finally the upper frame brace. Cap with a flat washer (R) and a 1/2”-13 nylon lock nut (X) (Fig. 4). Leave loose at this time.

AIR SPRING AND BRACKET ASSEMBLY

1. Set a roll plate (G) over the top and bottom of the air spring (H) (Fig. 1).

NOTE The radiused (rounded) edge of the roll plate (G) will be towards the air spring so that the air spring is seated inside both roll plates.

2. Install the swivel elbow fitting (Z) into the top of the air spring finger-tight. Tighten the swivel fitting one and a half turns.
3. The lower bracket (A) has two sets of air spring mounting holes. Using the corresponding holes in the lower bracket designated (Fig. 5), attach the air spring to the brackets using the 3/8" flat washers (W), lock washers (U), and 3/8"-24 x 7/8" hex head cap screws (N). Torque both mounting screws to 20 lb.-ft (27Nm).

NOTE The fitting on top of the air spring points inward (Fig. 7).

4. Insert two 3/8"-16 x 1 1/4" carriage bolts (P) up through the bottom of the upper brackets (Fig. 7), through the two square holes that are on the corresponding side. Also, insert one 3/8"-16 x 2 1/2" carriage bolt (M) through the remaining hole. The head of this carriage bolt will be hidden once mounted to the air spring.
5. Set the driver side (left) upper bracket onto the driver side air spring assembly previously assembled, using the holes in the upper bracket designated (Fig. 6), and attach to the air spring with two 3/8" flat washers (W), lock washers (U), and 3/8"-24 x 7/8" hex head cap screws (N). Torque both mounting screws to 20 lb.-ft (27Nm).
6. Repeat the above process for the opposite side assembly (Fig. 7).
7. Set the spacer (F) over both long carriage bolts (Fig. 7).

NOTE The hole in the flat spacer (F) is offset. Install the spacer so that the wide portion faces the outside of the vehicle (Fig. 7).

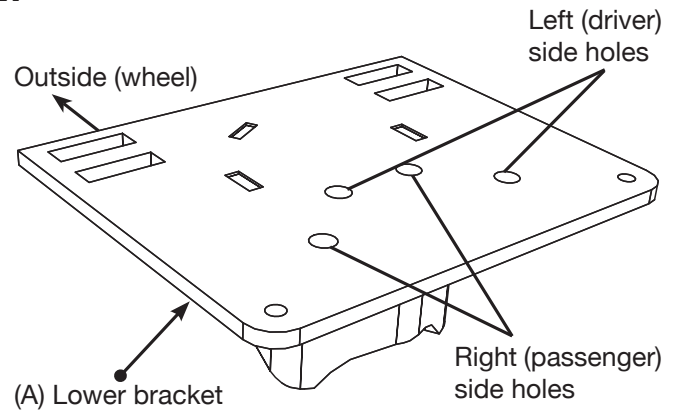

Fig. 5

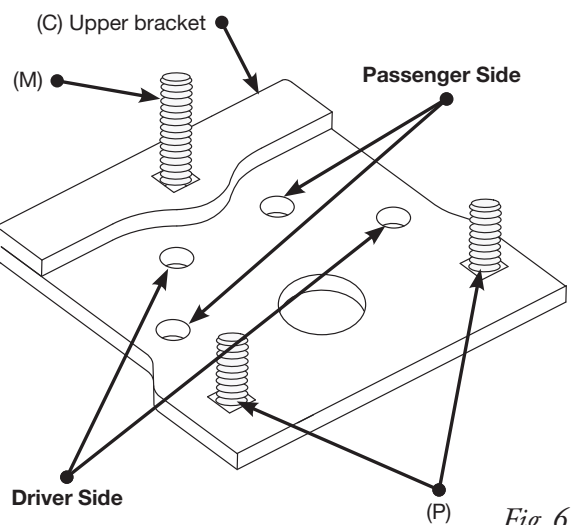

Fig. 6

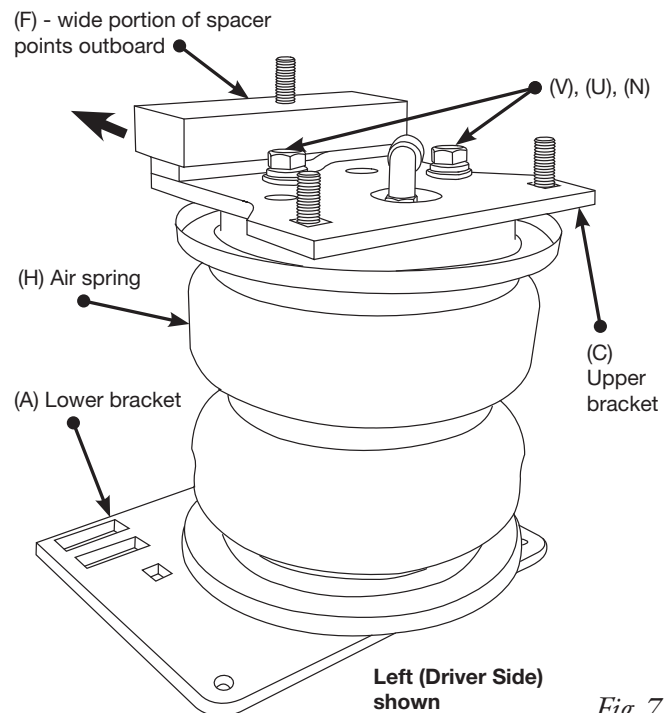

Fig. 7

ATTACHING THE ASSEMBLIES TO THE FRAME

1. If not done so yet, drop the axle or raise the frame up to make room for the assemblies to be put into position.
2. Set the left (driver side) assembly onto the axle (Fig. 1). Raise the axle just enough to insert the long carriage bolt (M) (that is installed in the upper bracket) through the existing jounce bumper hole in the bottom of the frame. At the same time, line up the upper brace previously installed onto the remaining two carriage bolts (P) in the upper bracket. Do this just enough for the carriage bolt to hold the assembly into position on the axle (Fig. 1).
3. Set the right (passenger side) assembly into position on the axle the same way the left side was positioned (Fig. 1).
4. Raise the axle or lower the frame down so that the thick spacer (F) on the upper bracket is parallel to, and contacts the frame (on both sides).
5. Install the 3/8" flat washer (W) and a 3/8"-16 nylon lock nut (V) on the carriage bolt (M) that went through the existing jounce bumper hole and tighten securely on both sides (Fig. 1).



BE SURE NOT TO PINCH THE PREVIOUSLY MOVED WIRING OR LINES INSIDE THE LEFT FRAME RAIL.

6. Cap the brace/upper bracket carriage bolts (P) with a 3/8" flat washer (W) and 3/8" nylon lock nut (V) and tighten both securely on both sides.
7. With the spacers (F) on the upper brackets tight to the bottom of the frame and the braces tight to the upper bracket, tighten the 1/2 or 3/4" hardware previously installed, that hold the braces to the frame. Tighten both sides securely.
8. If so equipped with the emissions line previously loosened from the frame, insert the line holder post into the L-bracket (J) attached to the back leg of the upper left brace (B) (Fig. 8). It may be necessary to move the line holder post forward or back on the lines to line up correctly with the L-bracket hole. Reattach any line holders removed forward or behind the axle, if possible, that were removed to aid in positioning the upper bracket.

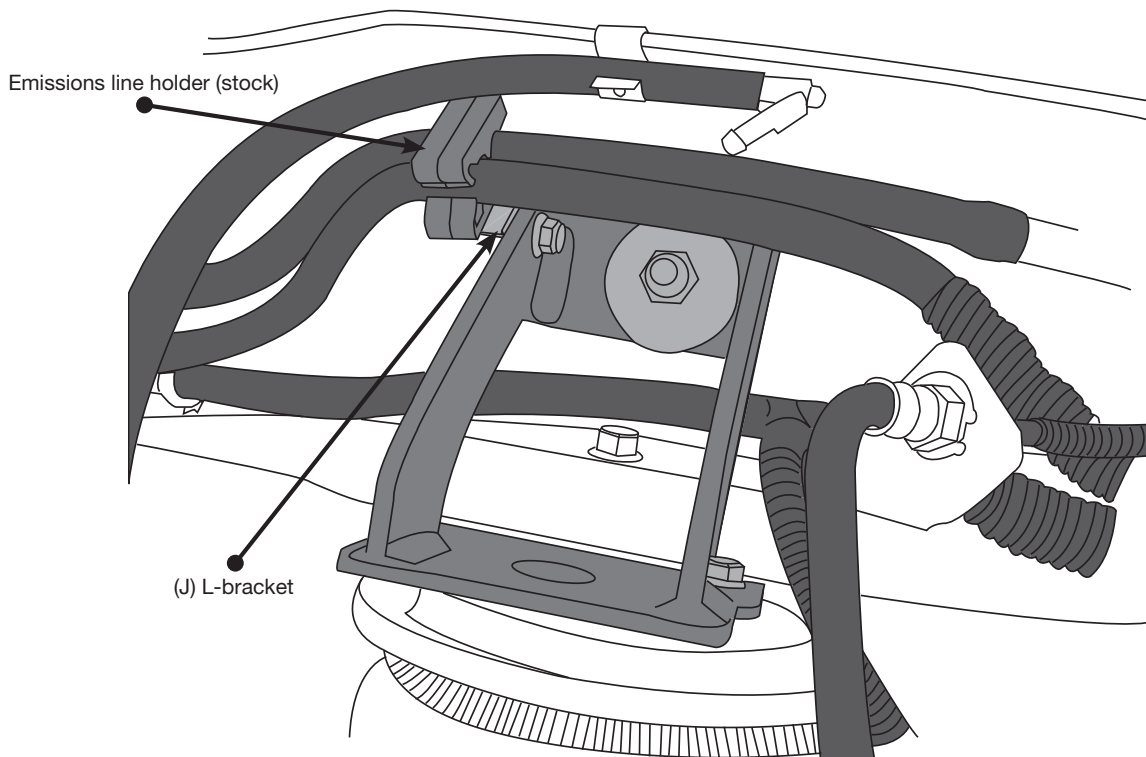

Fig. 8

LOWER BRACKET ATTACHMENT



ATTACHING THE LOWER BRACKET WILL DEPEND ON THE MODEL TRUCK YOU HAVE. SEE FIGURE 10 TO DETERMINE WHICH HOLES TO USE FOR INSERTING THE CARRIAGE BOLTS.

1. Insert a 3/8"-16 x 5 1/2" hex head bolt (K) and flat washer (W) into one of the two bottom holes of the locating bracket (I) (Fig. 9).



Use the hole that is closest to the leaf spring.

- 2a. If you are installing this kit on a single rear wheel (SRW) vehicle, use position 2 to insert the long 3/8"-16 x 10" carriage bolt (Q) through the top of the locating bracket and lower bracket (Fig. 9).
- 2b. If you are installing this kit on a dual rear wheel (DRW) vehicle, use position 1 to insert the long 3/8"-16 x 10" carriage bolt (Q) through the top of the locating bracket and lower bracket (Fig. 9).
3. Attach the locating bracket (I) to the lower bracket with a 3/8"-16 x 1 1/4" carriage bolt (P), flat washer (W) and nylon lock nut (V) using the remaining slot in the top of the locating bracket. Leave loose at this time.
4. Push the front and back locating brackets against the u-bolts and tighten the short carriage bolts at this time.
5. Using the 3/8"-16 x 5 1/2" hex head bolts (K) and flat washers (W) previously installed on the locating brackets, insert them into the spring clamp bar (E) on the opposite side of the leaf spring assembly (Fig. 9). Cap with 3/8" flat washers (W) and nylon lock nuts (V). Leave loose at this time.
6. Set the axle clamp bar (D) onto the long 3/8"-16 x 10" carriage bolts (Q) (Fig. 1) and cap with 3/8" flat washers (W) and nylon lock nuts (V).



If you have a sway bar under the axle and the carriage bolt (Q) interferes, invert the carriage bolt.

7. Carefully draw the side hardware and axle hardware evenly. Torque the spring clamp bar bolts to 10 lb.-ft (14Nm), and the axle clamp bar bolts to 16 lb.-ft (22Nm). Repeat for opposite side. Trim carriage bolts below nylon lock nuts if necessary.

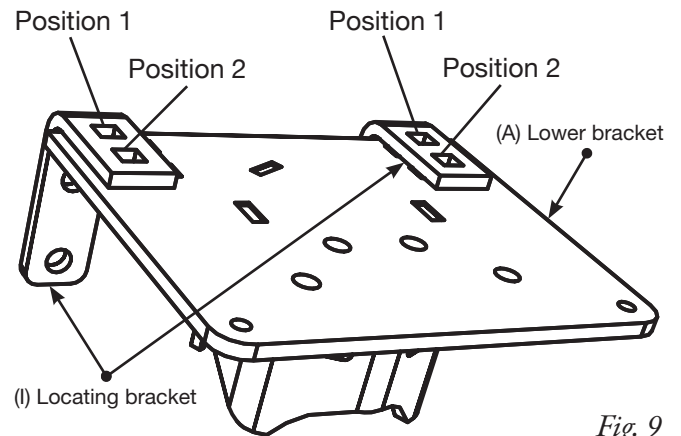

Fig. 9

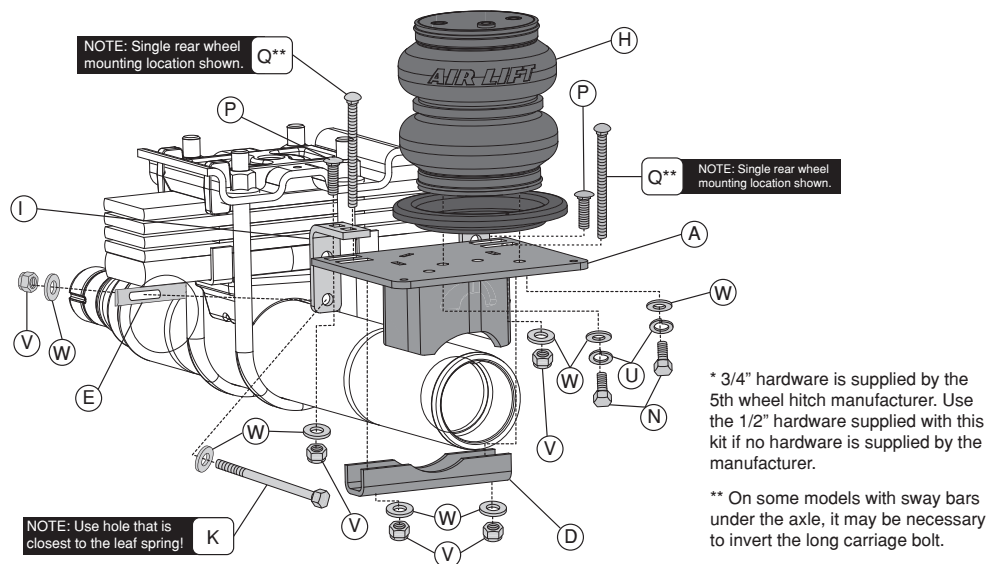
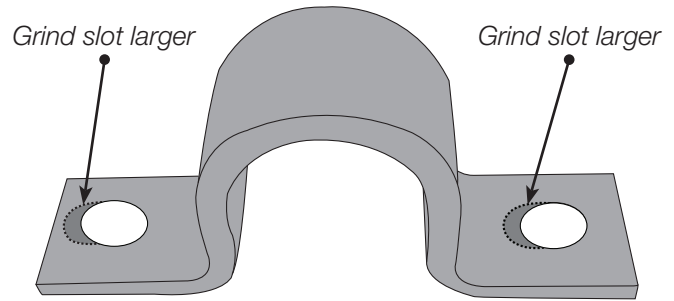

Fig. 10

NOTE

For 2WD and 4WD DRW vehicles, in order to install the sway bar and sway bar retaining straps back onto the axle, it will be necessary to slot the retaining straps (Fig. 11). Reattach the sway bar once this is done.

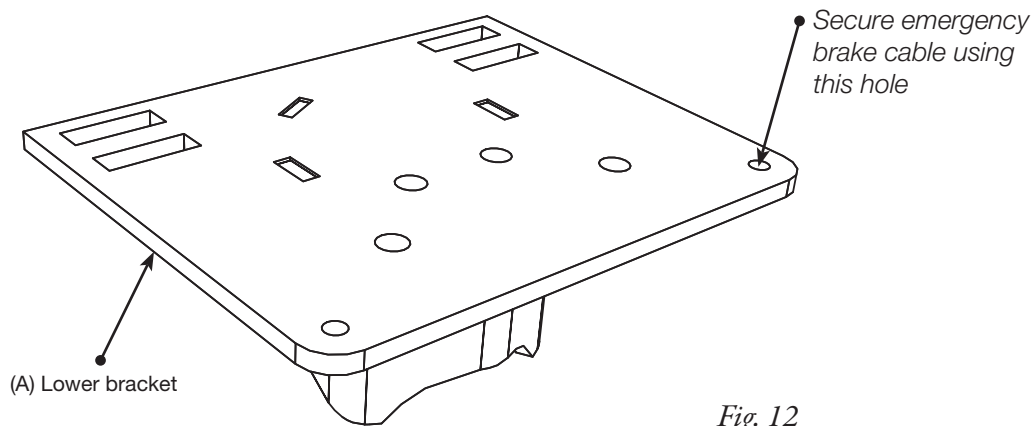

Fig. 11
FINAL STEPS

1. The emergency brake cable will have to be re-located away from the air spring.



FAILURE TO DO SO MAY CAUSE FAILURE TO THE AIR SPRING AND VOID THE WARRANTY.

2. Secure the emergency brake cable to the bottom bracket with supplied zip tie using the hole in the corner of the lower bracket (Fig. 12).

Fig. 12

Installing the Air Lines

Begin by choosing locations for the Schrader valves and drill a 5/16" (8mm) hole, if necessary.

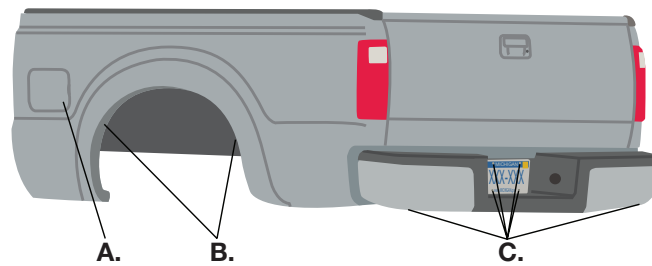

A. Inside fuel tank filler door B. Inside rear wheel wells C. License plate or rear bumper area



KEEP AT LEAST 6" (150MM) OF CLEARANCE BETWEEN ALL AIR LINES AND THE EXHAUST SYSTEM. AVOID SHARP BENDS AND EDGES.

INSTALLING NYLON AIR LINES

LoadLifter 5000 and LoadLifter 5000 Ultimate kits utilize nylon air lines. The nylon air lines are routed from the air springs to Schrader valves.

1. For nylon air line, it is recommended that the air line be routed along the top of the frame, forward of the axle, then down to the fitting. After cutting the air line to length, install the air line thermal sleeve over the air line on the passenger's (right) side before inserting into the fitting. Secure the air lines to the upper coil spring mount with zip ties (BB) supplied.
2. Cut the air line in half. Make clean, square cuts with a razor blade or hose cutter. Do not use scissors or wire cutters.

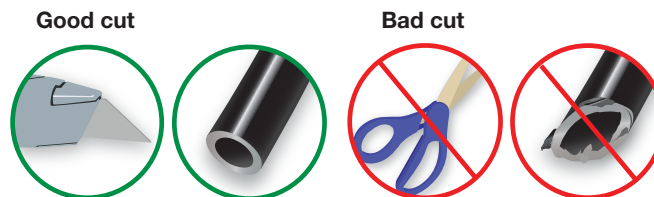

3. Use zip ties to secure the air line to fixed points along the chassis. Do not pinch or kink the air line. The minimum bend radius for the air line is 1" (25mm). Leave at least 2" (50mm) of slack in the air line to allow for any movement that might pull on the air line.
4. Install the Schrader valve in the chosen location.

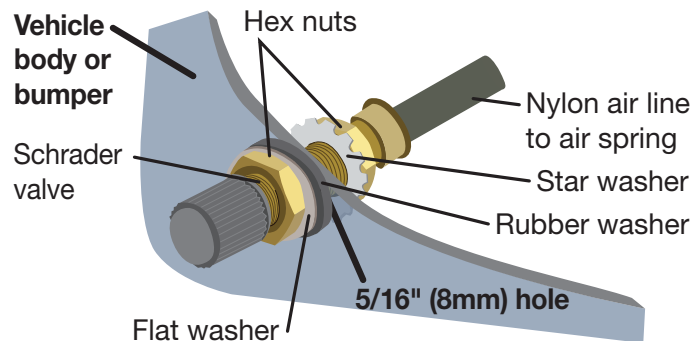

INSTALLING THE HEAT SHIELD

1. Attach the metal heat shield to the exhaust where it is closest to the air spring. Slide the air line thermal sleeve over the air line and place it where the air line is closest to the exhaust.

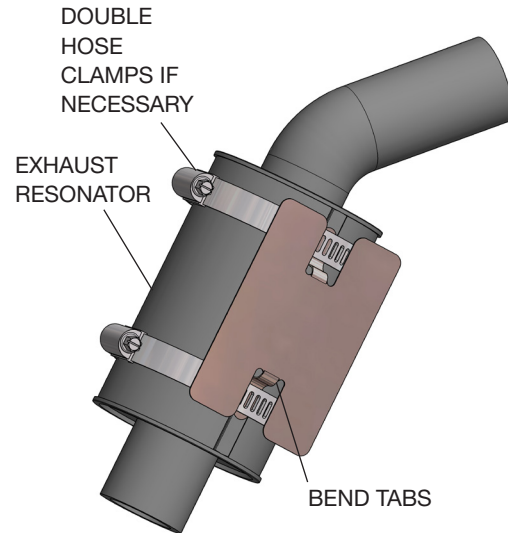
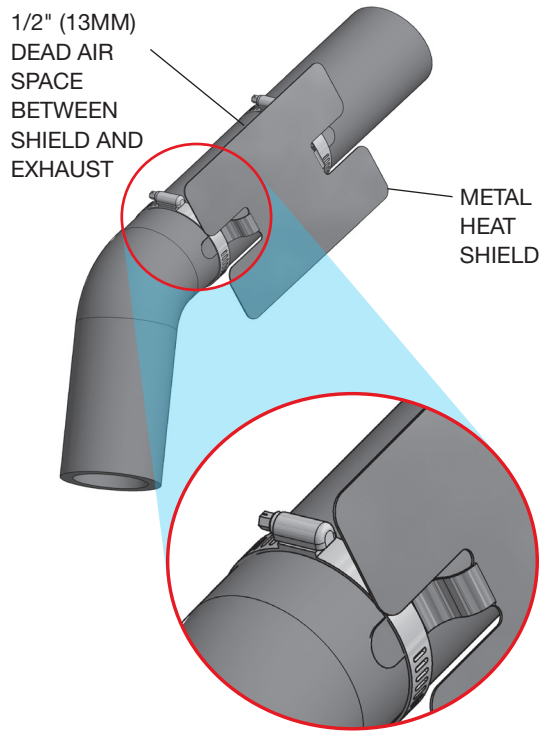

Before Operating

INSTALLATION CHECKLIST

- ❑ **Clearance test** — Inflate the air springs to 40-60 PSI (2.8-4.1BAR) and make sure there is at least 1/2" (13mm) clearance from anything that might rub against each sleeve. Be sure to check the tire, brakes, frame, shock absorbers and brake cables.
- ❑ **Leak test before road test** — Inflate the air springs to 40-60 PSI (2.8-4.1BAR) and check all connections for leaks. All leaks must be eliminated before the vehicle is road tested.
- ❑ **Heat test** — Be sure there is sufficient clearance from heat sources, at least 6" (152mm) for air springs and air lines. If a heat shield was included in the kit, install it. If there is no heat shield, but one is required, call Air Lift customer service at (800) 248-0892.
- ❑ **Fastener test** — After 500 miles (800km), recheck all bolts for proper torque.
- ❑ **Road test** — The vehicle should be road tested after the preceding tests. Inflate the air springs to recommended driving pressures. Drive the vehicle 10 miles (16km) and recheck for clearance, loose fasteners and air leaks.
- ❑ **Operating instructions** — If professionally installed, the installer should review the operating instructions with the owner. Be sure to provide the owner with all of the paperwork that came with the kit.

MAINTENANCE AND USE GUIDELINES

1. Check air pressure weekly.
2. Always maintain normal ride height. Never inflate beyond 100 PSI (7BAR).
3. If the system develops an air leak, use a soapy water solution to check all air line connections and the inflation valve core before deflating and removing the air spring.
4. Upon successful completion of the installation, follow these pressure requirements for the air springs.



**Minimum Recommended
Air Pressure**



Maximum Air Pressure



FOR SAFETY AND TO PREVENT POSSIBLE DAMAGE TO THE VEHICLE, DO NOT EXCEED MAXIMUM GROSS VEHICLE WEIGHT RATING (GVWR) OR PAYLOAD RATING, AS INDICATED BY THE VEHICLE MANUFACTURER.

ALTHOUGH THE AIR SPRINGS ARE RATED AT A MAXIMUM INFLATION PRESSURE OF 100 PSI (7BAR), THE AIR PRESSURE ACTUALLY NEEDED IS DEPENDENT ON LOAD AND GROSS VEHICLE WEIGHT RATING.



Notes

Notes



Limited Warranty and Return Policy

Air Lift Company provides a limited lifetime warranty to the original purchaser of its load support products, that the products will be free from defects in workmanship and materials when used on cars and trucks as specified by Air Lift Company and under normal operating conditions, subject to the requirements and exclusions set forth in the full Limited Warranty and Return Policy that is available at www.airliftcompany.com/warranty.

For additional warranty information contact Air Lift Company customer service.



Thank you for purchasing Air Lift Products — the Authorized Installer's choice!

Need Help?

Contact Air Lift Company Customer Service at (800) 248-0892
or email service@airliftcompany.com.

For calls outside the U.S. or Canada, dial (517) 322-2144.



Air Lift Company • 2727 Snow Road • Lansing, MI 48917 or P.O. Box 80167 • Lansing, MI 48908-0167

Air Lift Company reserves the right to make changes and improvements to its products and publications at any time.
For the latest version of this manual, contact Air Lift Company at (800) 248-0892 or visit airliftcompany.com.