

# ELECTRIC PYROMETER GAUGE WITH WARNING INDICATOR, PEAK RECALL AND PRO CONTROL

2650-1333-00



## Important

Pyrometers are sensitive, high accuracy instruments. They must be handled and installed with care to insure proper performance. Carefully read and follow these instructions, and your pyrometer will provide you with a long and accurate life.

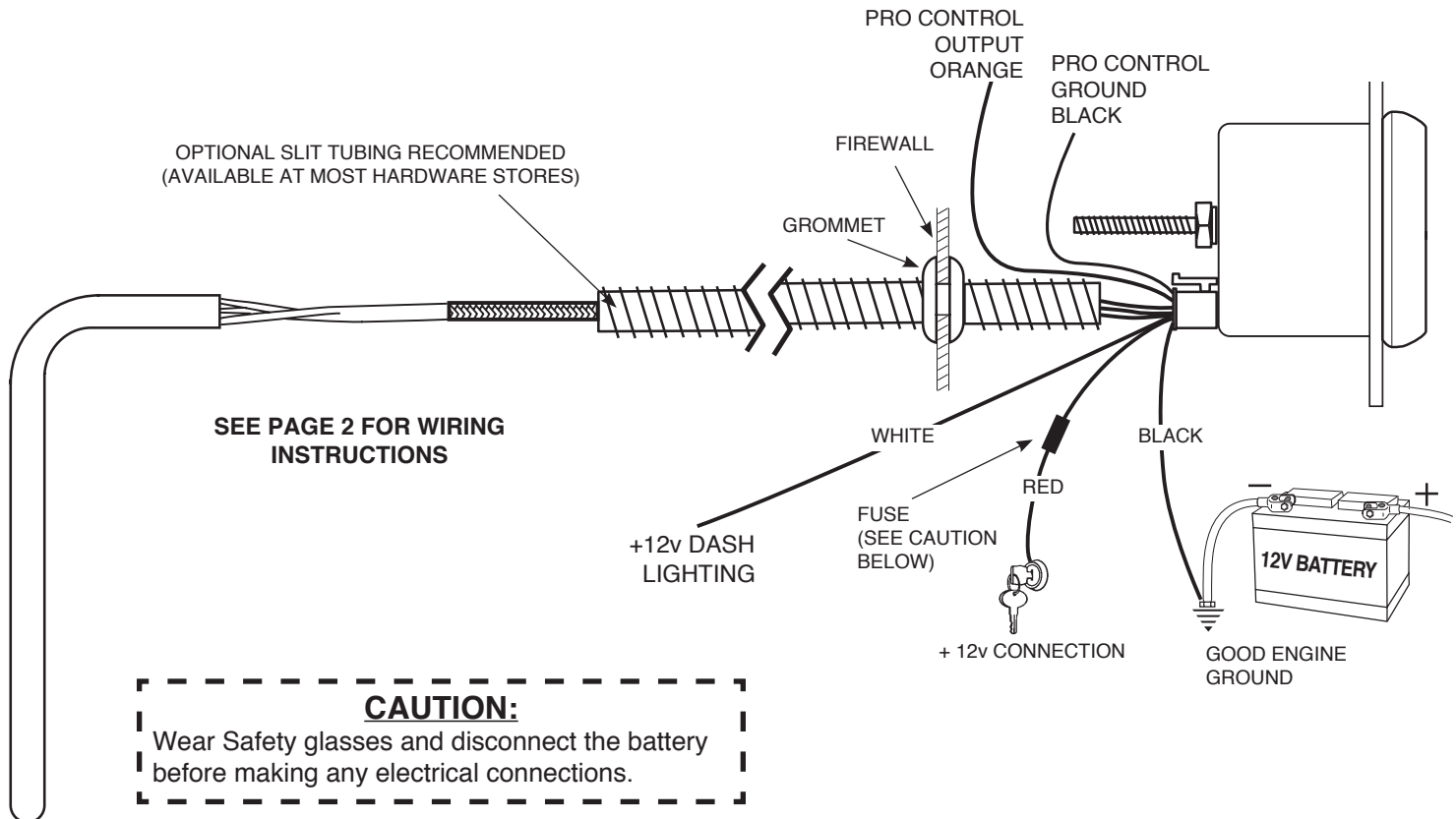

**CAUTION:**  
Wear Safety glasses and disconnect the battery before making any electrical connections.

**CAUTION:**  
As a safety precaution, the +12V terminal of this product should be fused before connecting to the 12V ignition switch. We recommend using a 1 Amp, 3AG fast-acting type cartridge fuse (Littlefuse® # 312 001 or an equivalent).

**NOTE:** When the ignition is off the pointer may not always rest at zero.

## INSTALLATION

1. Check that you have all parts required for installation, and the engine is cool.
2. Disconnect the negative (-) battery cable.
3. Gauge mounts in a 2 1/16" hole. Use supplied brackets and nuts to secure gauge to dash.
4. Drill 1" diameter hole where wires pass through sheet metal (such as firewall) and install rubber grommet provided. (Grommet will require slit.)
5. Connect the white wire to dash lighting or switchable 12v light source, red wire from harness to +12V terminal on ignition switch or other +12V power source, and black wire to ground.
6. Reconnect negative (-) battery cable.

# PROBE INSTALLATION

1. Begin by installing the thermocouple in the exhaust, then work back to the gauge. Installing the probe in the proper location will insure optimal temperature readings. For non-turbo engines, install the probe 1-2 inches from the cylinder head. For turbo engines, remove the exhaust manifold and install the probe 1-2 inches from the cylinder head. If the exhaust manifold can not be removed, install the probe 1-2 inches after the turbo exhaust outlet (Exhaust gas temps could drop over 200° when installing after the turbo). **CLEAN ALL METAL FILINGS** out of the exhaust manifold. Metal filings will damage the turbo impellor if they go through the turbo.

The probe can be mounted in two different ways, so please use the method best suited for your needs.

- A) **Pre-existing 1/8" NPT Threaded Hole:** Simply screw the threaded fitting into the hole, insert the probe, and tighten the set screw snugly onto the probe. (Caution: do not over tighten set screw or damage to probe may occur.) Make sure the probe is oriented so the wires do not come in contact with, or become too close to the manifold or other hot engine parts. See illustration for details.
  - B) **Stainless Clamp Method:** This method is for applications that require frequent removal of the manifold or header for service, or just faster and easier installation. Drill a 7/16" diameter hole about 6" down from the junction of the exhaust pipe to manifold junction. Undo the clamp and slide the probe into the hole in the clamp. Slide the set screw collar onto the probe. Before tightening the collar in position make sure that when inserted, the probe will have its tip in the middle two-thirds of the exhaust stream. Tighten screw collar in position. (Caution: do not over tighten set screw or damage to probe may occur.) Hold the clamp open when inserting the probe into the 13/32" hole. Re-join the clamp ends and tighten in position. Make sure the probe is oriented so the wires do not come in contact with, or become too close to the manifold or other hot engine parts. See the illustration below for details.
2. With the probe installed, the wire harness can now be routed to the gauge. The wire harness is an integral part of the pyrometer calibration. It may not be shortened or lengthened without affecting the gauge calibration. You will need to determine a suitable location to coil the excess wire, and tie it loosely with a wire tie. (Loosely tying the excess coil prevents embrittlement caused by vibration.) Pass the harness through the fire wall using an existing hole, or drill a 1" diameter hole and use the rubber grommet provided to protect the wire from damage.

**A. Pre-existing 1/8" NPT Threaded Hole**

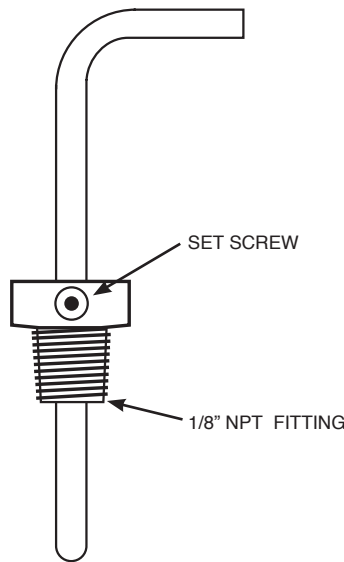

**B. Stainless Clamp Method**

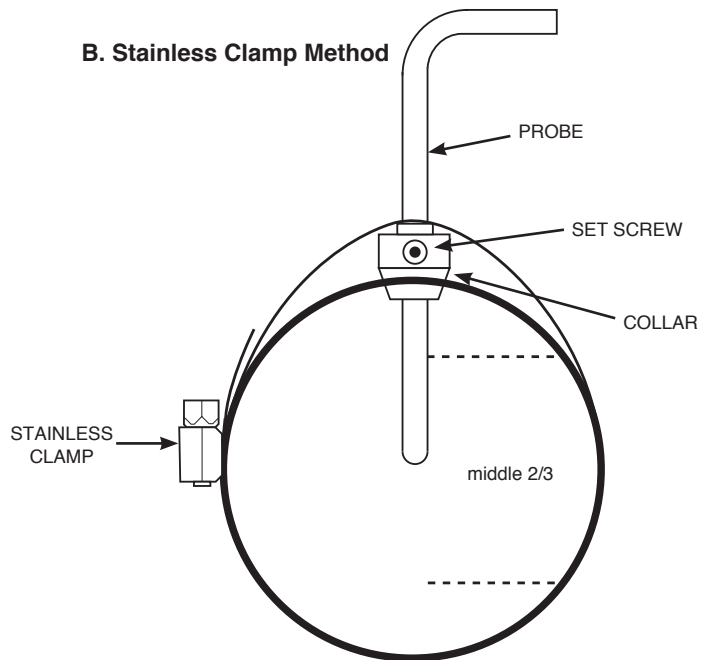

---

## Power-Up

The pointer will move backward to the stop pin and then display actual temperature. This procedure is an auto-calibration function and is performed on every power-up. While this test is being performed, the gauge may make a clicking sound. This is normal.

---

## Warning Indicator

To adjust the warning set point, momentarily press and release the WARN button. The warning light will begin to flash and the pointer will move to the previous set point signifying that warning set mode has been selected. Once in set mode, press the WARN button to move the pointer down, or press the PEAK button to move the pointer up. Three seconds after the last button press, the warning light will stop blinking and the pointer will return to the current temperature reading. The warning set point is retained when power is removed from the gauge. The warning set point is also the Pro Control set point.

---

## Peak Recall

Press and hold the PEAK button to recall the highest temperature reading since the memory was last cleared. To clear the memory, press and hold the PEAK button, and while still holding the PEAK button, press the WARN button. The pointer will move to the stop pin to indicate that the memory has been cleared. Release the PEAK and WARN buttons to resume normal operation. The peak recall point is retained when power is removed from the gauge.

# Pro Control

The Pro Control feature activates a switched ground output at a user defined set point. Pro Control can be used to switch on a relay to activate ignition kill, cooling fans, lamps, alarms, etc.

The Pro Control set point is the same as the Warning Indicator set point. Follow the directions above for Warning Indicator to change the set point.

The set point defines two regions on the gauge dial, the region below the set point and the region above the set point. Like the Warning Indicator on the gauge, the Pro Control output is active in the region above the set point (high temperature).

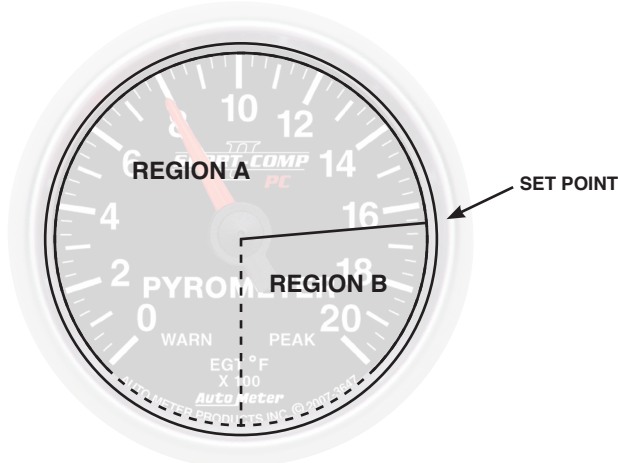

## PRO CONTROL RELAY DIAGRAM

POINTER REGION	PRO CONTROL OUTPUT	NORMALLY OPEN CONTACT	NORMALLY CLOSED CONTACT	WARNING INDICATOR
A	OFF	OPEN (OFF)	CLOSED (ON)	OFF
B	Active (ON)	CLOSED (ON)	OPEN (OFF)	ON

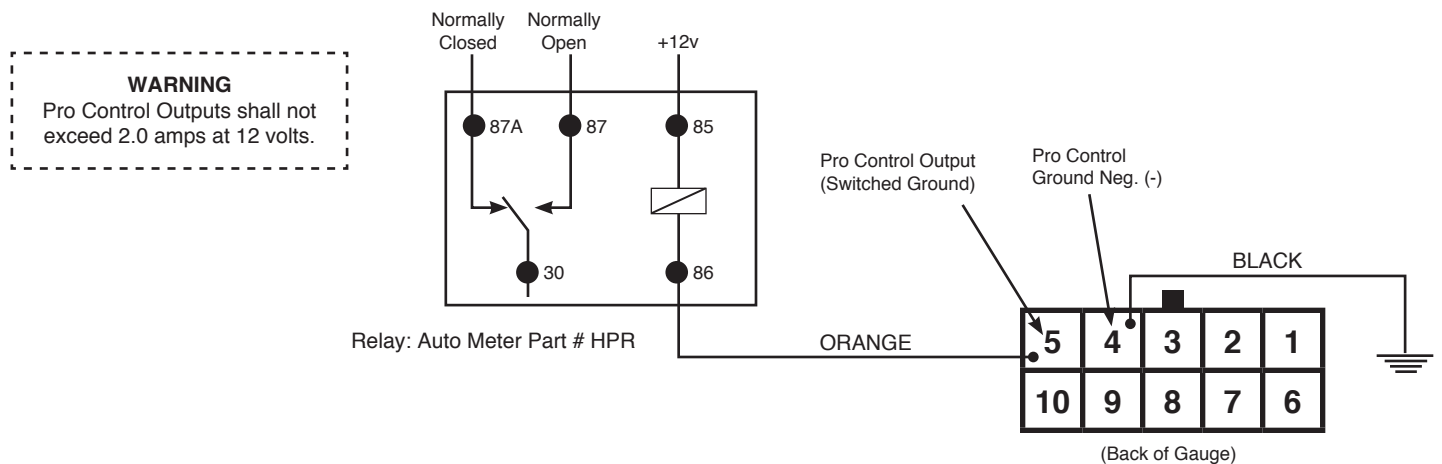

## SERVICE

For service send your product to Auto Meter in a well packed shipping carton. Please include a note explaining what the problem is along with your phone number. Please specify when you need the product back. If you need it back immediately mark the outside of the box "RUSH REPAIR," and Auto Meter will service product within two days after receiving it. (\$10.00 charge will be added to the cost of "RUSH REPAIR.") If you are sending product back for Warranty adjustment, you must include a copy (or original) of your sales receipt from the place of purchase.

## 12 MONTH LIMITED WARRANTY

Auto Meter Products, Inc. warrants to the consumer that all Auto Meter High Performance products will be free from defects in material and workmanship for a period of twelve (12) months from date of the original purchase. Products that fail within this 12 month warranty period will be repaired or replaced at Auto Meter's option to the consumer, when it is determined by Auto Meter Products, Inc. that the product failed due to defects in material or workmanship. This warranty is limited to the repair or replacement of parts in the Auto Meter instruments. In no event shall this warranty exceed the original purchase price of the Auto Meter instruments nor shall Auto Meter Products, Inc. be responsible for special, incidental or consequential damages or costs incurred due to the failure of this product. Warranty claims to Auto Meter must be transportation prepaid and accompanied with dated proof of purchase. This warranty applies only to the original purchaser of product and is non-transferable. All implied warranties shall be limited in duration to the said 12 month warranty period. Breaking the instrument seal, improper use or installation, accident, water damage, abuse, unauthorized repairs or alterations voids this warranty. Auto Meter Products, Inc. disclaims any liability for consequential damages due to breach of any written or implied warranty on all products manufactured by Auto Meter.

FOR SERVICE SEND TO: **AUTO METER PRODUCTS, INC.** 413 W. Elm St., Sycamore, IL 60178 USA (815) 899-0801

Email us at [service@autometer.com](mailto:service@autometer.com)

<http://www.autometer.com>

The Super Bezel is a registered trademark of Auto Meter Products, Inc.