

This model **5257** Pyrometer Module will only work the latest version of incandescent lit pyrometers. An incandescent pyrometer uses a twist in light socket toward the top of the rear of the gauge. The latest version will also use a 10-cavity, black connector that plugs into the rear of the gauge. The earlier version uses two threaded posts for the probe thermocouple wire connections and a red & black wire coming out of the bottom of the rear of the gauge. This module will **NOT** function with the early version. This module also will not function correctly with the factory LED lit version (with no twist in light socket).

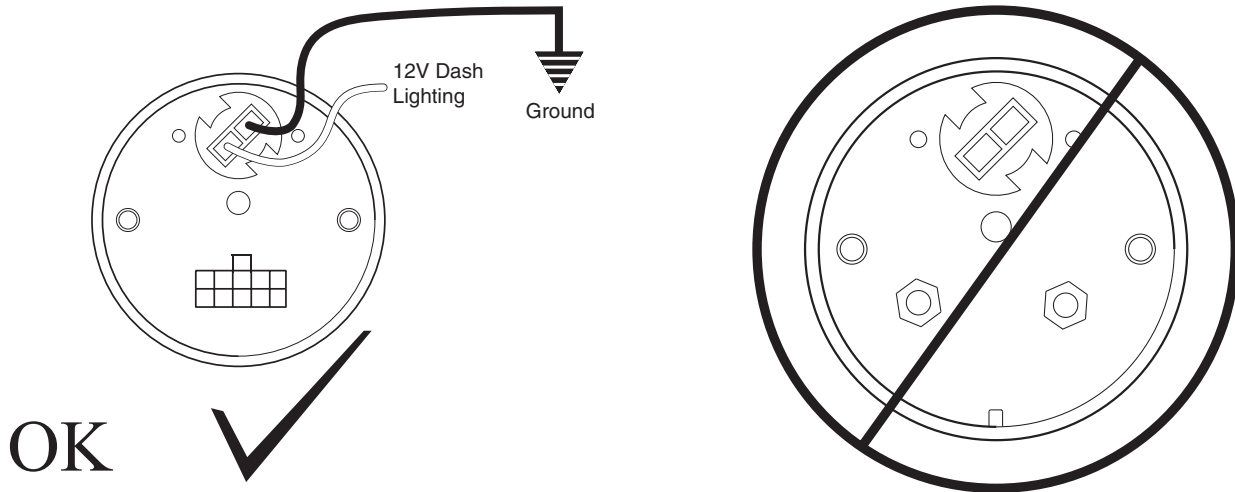

Product Overview

The Pyrometer Extension Module (PEM) has been design to be used with Auto Meter pyrometers in applications where the distance from the engine and the driver is longer than normal (i.e. rear engine motor homes and coaches).

The PEM is comprised of two components: a thermocouple amp and driver module (TCA - black case), and a new gauge harness containing a signal shunt module (shunt). The TCA has been designed to be placed near the engine compartment, but behind the fire wall, of a long vehicle with a rear-mounted engine and drive train (i.e. a pusher bus). The TCA will convert the signal generated by a K-type thermocouple (EGT probe)

mounted in the exhaust of the engine to a proportional output current that ranges from near 0 to 20mA. This current can be delivered over a pair of wires up to 75' to the shunt. The output of the shunt will be connected to the thermocouple inputs of a standard incandescent lit Auto Meter pyrometer gauge. It will not operate on LED lit pyrometers that utilize the black 10 pin connector on the back of the gauge.

The dynamic operating range of the TCA limits the lowest temperature signal to approximately 160°F. This is a design limitation. All temperatures measured by the EGT probe at or below this limit will result in a minimum reading on the pyrometer gauge at approximately 160°F.

The connections to the PEM are made through the terminal strip on the TCA. The following table describes the connections:

Terminal	Signal	Description
1	Loop Output	Signal to Shunt Module (Orange)
2	Loop Ground	Signal Return from Shunt Module (Black)
3	12V	Switched power from vehicle
4	Ground	Vehicle ground
5	TC+ (Yellow)	Thermocouple + (Yellow)
6	TC- (Red)	Thermocouple - (Red)

Installation, TCA Module (black case)

The TCA (black case) should be mounted securely on the interior side of the firewall, in a location for convenient connections to the exhaust gas thermocouple being used. The TCA is not to be mounted where it is exposed to the outside elements. Looking at the terminal strip on the TCA from the side the wires are inserted, and the screws up, the terminals are numbered from left to right, 1 to 6.

1. The thermocouple wires from the pyrometer probe are to be connected to terminals #5 and #6. Connect the Yellow wire to #5, and the Red wire to #6.
2. Connect terminal #4 to a good chassis ground, engine ground or the negative of the battery.
3. Connect terminal #3 to a switched (12V) power supply.
4. Connect the Shunt Module extension wires as detailed on next page.

Shunt Module Wiring

5257 - The Shunt Module will be located and plugged into the pyrometer gauge mounted in the vehicles' dash. The Shunt Module comes with a new gauge connector to replace the connector/harness that came with the gauge.

The extension wires (user provided) used to connection the Shunt Module to the TCA need to be routed and secured along the vehicles' chassis. The use of 18AWG or 16AWG wire is recommended. Two closed end crimp splices are provided to make the connections to the extension wire. It is recommended to use black and orange wire colors for the extension wires in order to be certain of the connections to the TCA are correct. If another wire color is used, be sure the connections to the TCA are the correct polarity.

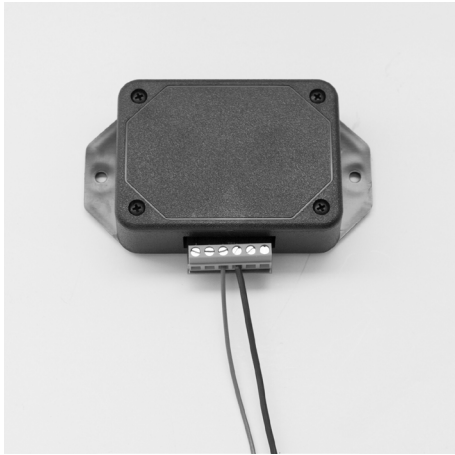

Wire power to terminal 3 of the module, and wire ground to terminal 4 of the module. We recommend 18g wire for this (terminal numbers are labeled on the back of module).

This module is provided with a new wire harness to plug into the rear of your gauge. You will however need to remove the two thermocouple wires (yellow & red in yellow sheathing) from your original gauge connector.

Figure 1

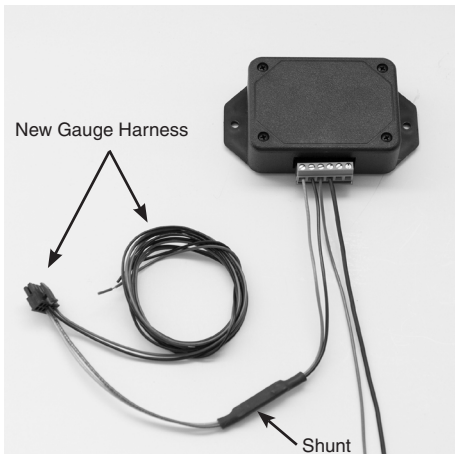

New gauge harness shown at left (but without the user supplied, extended wires between the shunt and the module).

You can pull the terminals from the original gauge connector by grasping the connector with a pair of pliers, then using another pair to pull the terminals from the connector (shown at the right, figure 1).

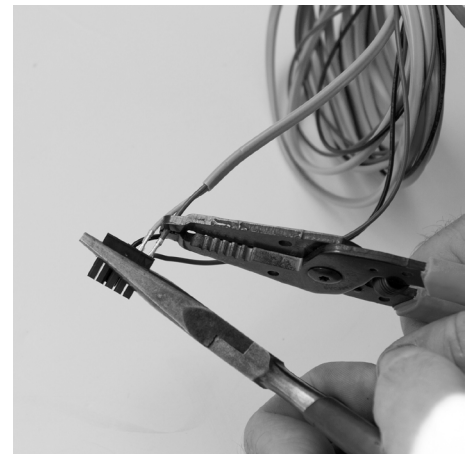

Cut the original gauge connector terminals off of the ends of these wires (figure 2), and strip 1/8" to 3/16" of insulation from each of these wires (figure 3). Insert the yellow thermocouple wire into terminal 5 of the module, and the red thermocouple into terminal 6 of the module (figure 4).

Figure 2

Figure 3

Figure 4

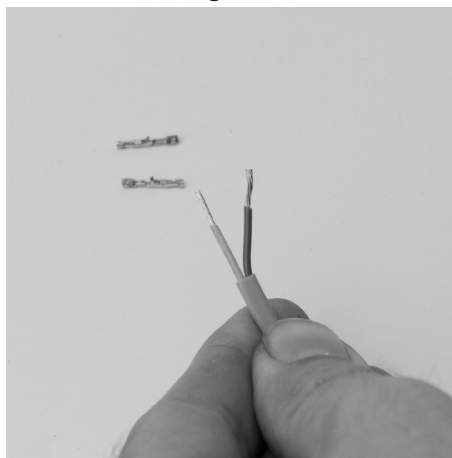
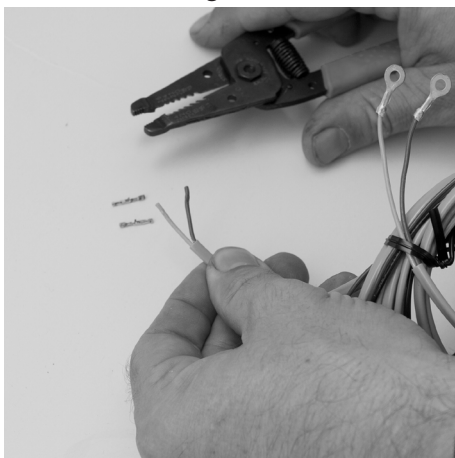

Plug the new supplied wire harness into the gauge. Connect the loose, red wire from the upper row of the new connector to 12v, key on power. Connect the loose, black wire from the upper row of the new connector to chassis ground. The red & yellow from the bottom row of the new connector go through a "Shunt", then turn into orange and black. You may now use your own 18g or 16g wire to connect from the orange and the black, to the module. Your newly extended orange wire goes to terminal 1,

and the newly extended black wire goes to terminal 2 of the module. This is illustrated in the wiring diagram on the next page.

Install the thermocouple probe into the exhaust per the gauge instructions, and connect the end of the thermocouple wires from the module to the thermocouple (red to red, and yellow to yellow).

EXTENSION MODULE

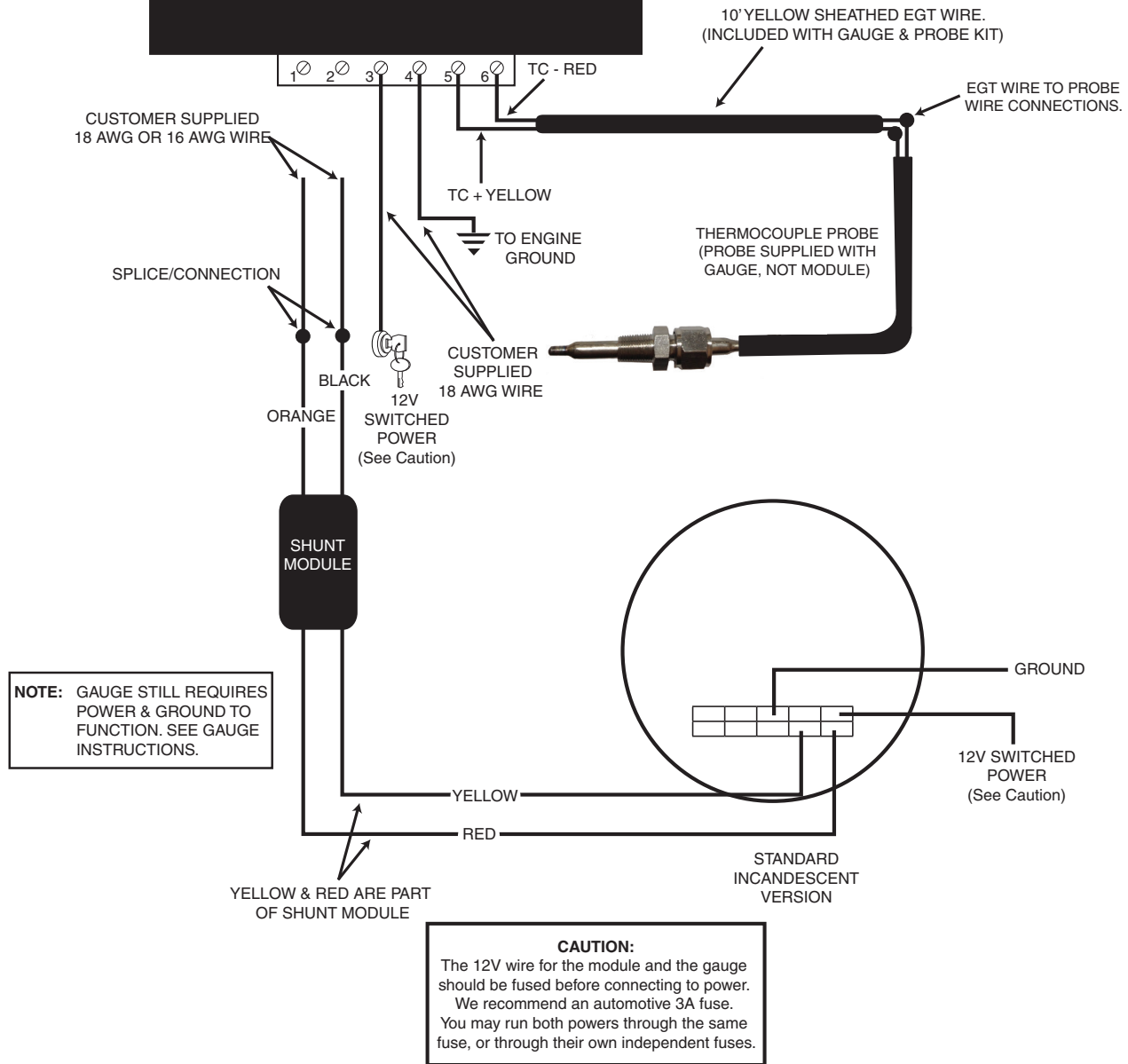

SERVICE

For service send your product to Auto Meter in a well packed shipping carton. Please include a note explaining what the problem is along with your phone number. If you are sending product back for Warranty adjustment, you must include a copy (or original) of your sales receipt from the place of purchase.

12 MONTH LIMITED WARRANTY

Auto Meter Products, Inc. warrants to the consumer that all Auto Meter High Performance products will be free from defects in material and workmanship for a period of twelve (12) months from date of the original purchase. Products that fail within this 12 month warranty period will be repaired or replaced at Auto Meter's option to the consumer, when it is determined by Auto Meter Products, Inc. that the product failed due to defects in material or workmanship. This warranty is limited to the repair or replacement of parts in the Auto Meter instruments. In no event shall this warranty exceed the original purchase price of the Auto Meter instruments nor shall Auto Meter Products, Inc. be responsible for special, incidental or consequential damages or costs incurred due to the failure of this product. Warranty claims to Auto Meter must be transportation prepaid and accompanied with dated proof of purchase. This warranty applies only to the original purchaser of product and is non-transferable. All implied warranties shall be limited in duration to the said 12 month warranty period. Breaking the instrument seal, improper use or installation, accident, water damage, abuse, unauthorized repairs or alterations voids this warranty. Auto Meter Products, Inc. disclaims any liability for consequential damages due to breach of any written or implied warranty on all products manufactured by Auto Meter.

FOR SERVICE SEND TO: **AUTO METER PRODUCTS, INC.** 413 W. Elm St., Sycamore, IL 60178 USA (866) 248-6357

Email us at service@autometer.com

<http://www.autometer.com>