



# INSTALLATION INSTRUCTIONS IN-DASH ELECTRIC TACHOMETER WITH INCANDESCENT LIGHTING

PART NUMBER P5155707



## QUESTIONS:

If after completely reading these instructions you have questions regarding the operation or installation of your instrument(s), please contact Mopar Technical Support at **(888) 528-HEMI**.

## Calibration

**IMPORTANT:** This tachometer is factory calibrated to operate on 8 cylinder engines. For 4 or 6 cylinder engines, it is necessary to make the proper adjustments to adapt this tachometer to your cylinder range.

Locate the black plastic plug covering the switch access hole. Remove the plastic plug covering the access hole. Use a small screwdriver or an unwound paper clip to change the switch settings. Move each of the two switches to the proper cylinder selection according to the diagram illustrated on the right. Reinstall the plastic plug/cap into the access hole.

**NOTE:** This tachometer has an air core meter. With power off, it is normal for the pointer to leave zero. When power is applied, the pointer will move to the correct position.

Figure A.

- 4 CYL. - Switch One up, Switch Two down
- 6 CYL. - Switch One down, Switch Two up
- 8 CYL. - Both switches up

If you are unsure of your vehicle's pulse(s) per revolution or specific calibration requirements, contact Mopar Technical Support at (888) 528-HEMI.

Figure A

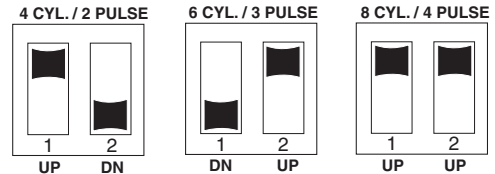

(Angle view through access hole)

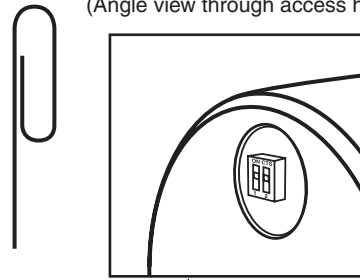

Access switch through access hole.

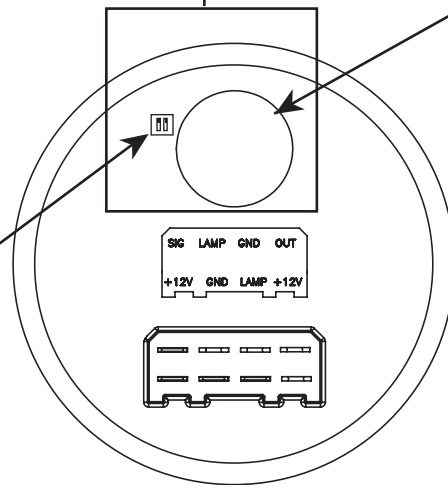

Switch is not visible from this angle, shown for location only.

## Lens Cleaning

To prevent scratching the lens when cleaning, use a mild, soapy solution to clean. Wipe lightly with a soft cloth.

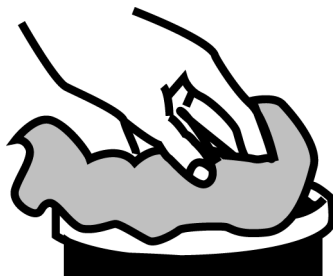

## Note:

This tachometer operates on most early model ignitions, factory electronic and high performance electronic racing ignitions.

# Mounting

1. Mount tachometer in a 3<sup>3</sup>/<sub>8</sub>" dia. hole. Be careful not to cut the hole too large.
2. Cut a 3<sup>9</sup>/<sub>8</sub>" dia. hole in the firewall for the tachometer wires. Place a rubber grommet in the hole and route the wires through the grommet to the engine compartment.
3. Connect the tachometer wires as shown in the wiring sections.
4. Secure the tachometer to the dashboard using the provided bracket and hardware.

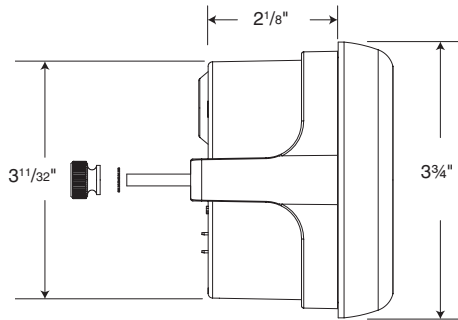

# Wiring

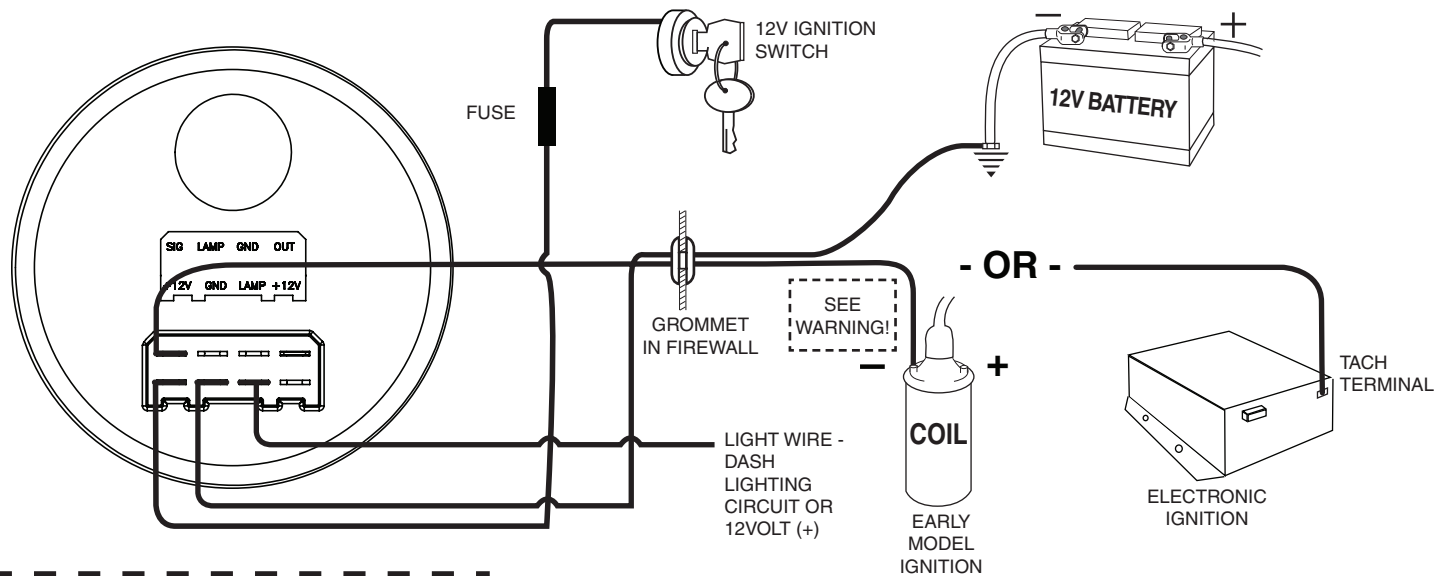

## WARNING

Warranty will be void if connected to coil when using an aftermarket ignition box such as, but not limited to products from the following manufacturers: MSD, Crane, Jacobs, Mallory, Holley, Etc.. Prior to installation of your tachometer, check with the ignition box manufacturer for recommended tachometer signal location.

## CAUTION!!!

As a safety precaution, the 12V terminal of this product should be fused before connecting it to the 12V ignition switch. We recommend using a 1 Amp, fast-acting automotive fuse.

## MOPAR PERFORMANCE PARTS ARE SOLD "AS IS," WITHOUT ANY WARRANTY WHATSOEVER.

Implied warranties, including warranties of merchantability or fitness for a particular purpose, are excluded. The entire risk as to quality and performance of such parts is with the buyer. Should such parts prove defective following their purchase, the buyer and not the manufacturer, distributor or retailer, assumes the entire cost of all necessary servicing or repair. Chrysler, Dodge, and Jeep® vehicle and parts warranties are voided if the vehicle or parts are used for competition or if they fail as a result of modification.

