



www.skyjacker.com

2005 - 2017 Ford Super Duty 1" - 2.5" Metal Spacer Installation Instructions

REQUIRED TOOL LIST:

- * Safety Glasses
- * Metric / Standard Wrenches & Sockets
- * Floor Jack
- * Jack Stands
- * Measuring Tape
- * Torque Wrench



Before beginning the installation, thoroughly & completely read these instructions & the enclosed driver's WARNING NOTICE. Affix the WARNING decal in the passenger compartment in clear view of all occupants. Please refer to the Parts List to insure that all parts & hardware are received prior to the disassembly of the vehicle. If any parts are found to be missing, contact SKYJACKER® Customer Service at 318-388-0816 to obtain the needed items. If you have any questions or reservations about installing this product, contact SKYJACKER® Technical Assistance at 318-388-0816.

Make sure you park the vehicle on a level concrete or asphalt surface. Many times a vehicle is not level (side-to-side) from the factory & is usually not noticed until a lift kit has been installed, which makes the difference more visible. Using a measuring tape, measure the front & rear (both sides) from the ground up to the center of the fender opening above the axle. Record this information below for future reference.

Driver Side Front: _____

Passenger Side Front: _____

Driver Side Rear: _____

Passenger Side Rear: _____

IMPORTANT NOTES:

- If larger tires (10% more than the OEM diameter) are installed, speedometer recalibration will be necessary. Contact your local Ford dealer or an authorized dealer for details.
- After installation, a qualified alignment facility is required to align the vehicle to the OEM specifications.

Kit Box Breakdown:

Part #: F51MS

<u>ITEM#</u>	<u>DESCRIPTION</u>	<u>QTY</u>
F51MS-S	1" METAL SPCR 05-11 F250/350	2
HB-F51MS	HDWR BAG: F51MS SPACER KIT	1
I-F51/52MS	INST SHEET: F51MS / F52MS	1

Hardware Bag Breakdown:

HB-F51MS HARDWARE BAG

<u>ITEM#</u>	<u>DESCRIPTION</u>	<u>QTY</u>
14X90MMB	14MM X 90MM - 2.0 TP BOLT	2
916XTFW	9/16"EXTRA THICK WASHER,GR8	2
LT100	NUTS N' BOLTS 427 1 ML TUBE	1

Part #: F52MS

<u>ITEM#</u>	<u>DESCRIPTION</u>	<u>QTY</u>
F52MS-S	2.5" METAL SPCR 05-11 F250/350	2
HB-F52MS	HDWR BAG: F52MS SPACER KIT	1
I-F51/52MS	INST SHEET: F51MS / F52MS	1

Hardware Bag Breakdown:

HB-F52MS HARDWARE BAG

<u>ITEM#</u>	<u>DESCRIPTION</u>	<u>QTY</u>
14X120MMB	14MM X 120MM - 2.0 TP BOLT	2
916XTFW	9/16"EXTRA THICK WASHER,GR8	2
LT100	NUTS N' BOLTS 427 1 ML TUBE	1

Installation:

1. With the vehicle on flat level ground, set the emergency brake & chock the rear tires.
2. Raise the front of the vehicle & support securely using jack stands.
3. While supporting front axle with a floor jack, remove the front tires / wheels using a 21mm socket.

4. Disconnect the drag link from the pitman arm using a 24mm socket & disconnect the front sway bar end links from the axle using 18mm & 21mm socket. (See Photo # 1)

5. Disconnect the upper & lower brake line brackets using a 10mm socket.

6. Disconnect the track bar from the track bar bracket using a 1 3/16" socket. (See Photo # 2)

7. Disconnect the front shocks from the axle using a 18mm socket & lower the axle so the coil springs can be removed. (See Photo # 3)

8. Remove the lower coil spring seat using a 18mm socket & install the new Skyjacker coil spring seat spacer, aligning the angle of the new coil spring seat spacer with the contour of the axle knuckle. (See Photo # 4)

9. Install the coil spring seat on top of the new coil spring seat spacer, aligning the angle of the new coil spring seat spacer with the contour of the coil spring seat. (See Photo # 4) **Note:** The OEM coil spring seat is labeled "FRT" designating the orientation of the coil spring seat on the vehicle. ↑

10. Install the supplied 9/16" washers onto the supplied 14mm bolts & apply the supplied thread locking compound to the threads of each new 14mm bolt. Install the new 14mm bolt thru the coil spring seat & new Skyjacker coil spring seat spacer & tighten using a 22mm socket. (See Photo # 4)

11. Install the coil springs & reconnect the front shocks using the OEM hardware & 18mm socket. (See Photo # 3)

12. Connect the track bar to the track bar bracket using the OEM hardware & 1 3/16" socket. (See Photo # 2)

13. Connect the upper & lower brake line brackets using the OEM hardware & 10mm socket.

14. Connect the drag link to the pitman arm using the OEM hardware & 24mm socket. Reconnect the front sway bar end links using the OEM hardware, 18mm, & 21mm socket (See Photo # 1)

15. Install the front tires / wheels using a 21mm socket & lower the vehicle to the ground.



Photo # 4

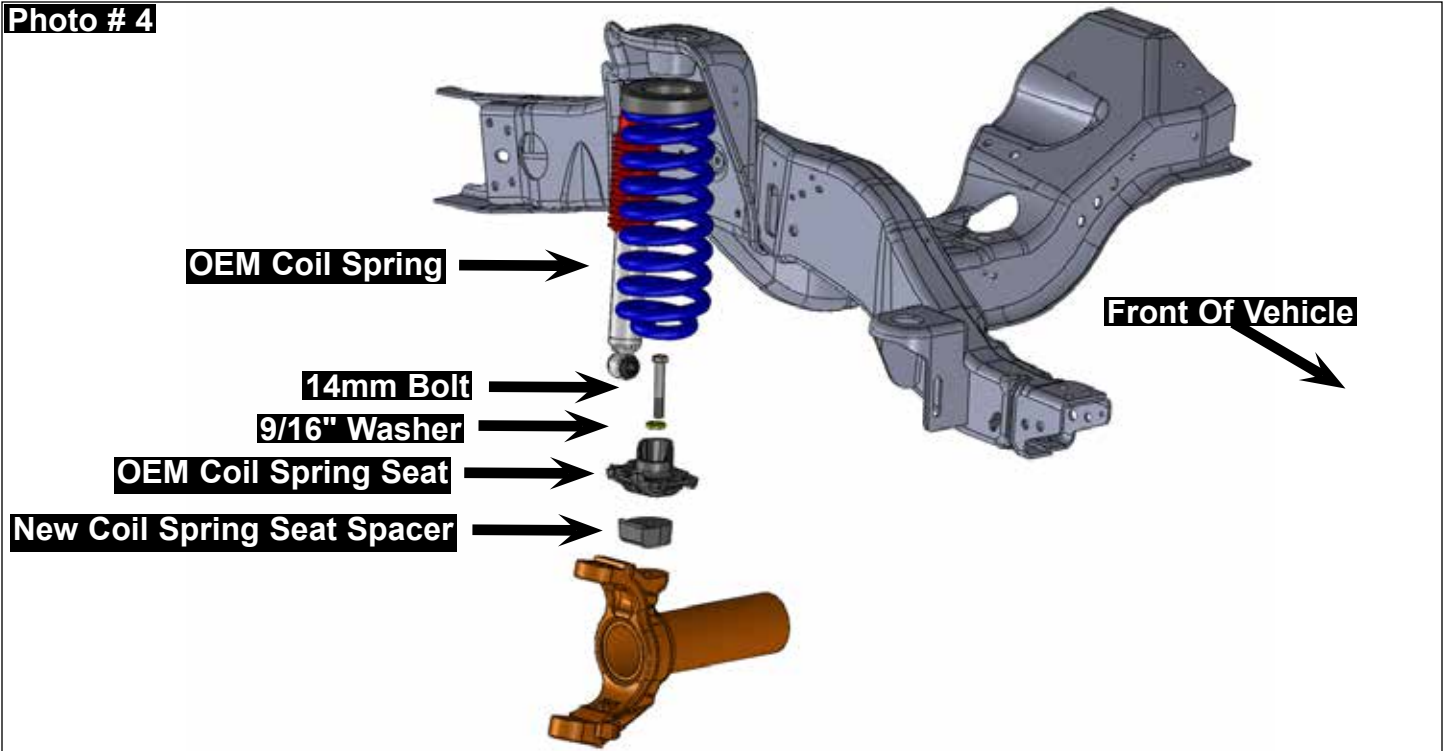

Final Notes:

- After the installation is complete, double check that all nuts & bolts are tight. Refer to the following chart for the proper torque specifications. (Do not retighten the nuts & bolts where thread lock compound was used.)
- With the vehicle placed on the ground, cycle the steering lock to lock & inspect the steering, suspension, brake lines, front & rear drivelines, fuel lines, & wiring harnesses for proper operation, tightness, & adequate clearance.
- Have the headlights readjusted to the proper settings.
- Have a qualified alignment center align the vehicle to the OEM specifications.
- After the first 100 miles, check all hardware for the proper torque & periodically thereafter.

TORQUE SPECIFICATIONS					
INCH SYSTEM			METRIC SYSTEM		
Bolt Size	Grade 5	Grade 8	Bolt Size	Class 8.8	Class 10.9
5/16	15 FT LB	20 FT LB	6MM	5 FT LB	9 FT LB
3/8	30 FT LB	35 FT LB	8MM	18 FT LB	23 FT LB
7/16	45 FT LB	60 FT LB	10MM	32 FT LB	45 FT LB
1/2	65 FT LB	90 FT LB	12MM	55 FT LB	75 FT LB
9/16	95 FT LB	130 FTLB	14MM	85 FT LB	120 FT LB
5/8	135 FT LB	175 FT LB	16MM	130 FT LB	165 FT LB
3/4	185 FT LB	280 FT LB	18MM	170 FT LB	240 FT LB

- The above specifications are not to be used when the bolt is being installed with a bushing.