



# **BD BrakeLoc EBP Valve Control** **Ford Powerstroke (Manual Transmissions)**

**Part# 1030755**

*\* Please read this instruction manual before starting installation \**

Installation Manual Part# I1030750  
Printed in Canada

BD Engine Brake, Inc.  
Plant Address: Unit A10, 33733 King Rd, Abbotsford, BC, Canada V2S 7M9  
U.S. Shipping Address: #88-446 Harrison St, Sumas, WA 98295 U.S. Mailing Address: P.O. Box 231, Sumas, WA 98295  
Phone: 604-853-6096 Fax: 604-853-8749 Internet: [www.bd-power.com](http://www.bd-power.com)

# TABLE OF CONTENTS

Welcome ..... 3  
The BD BrakeLoc Advantage ..... 3  
Operating the BD BrakeLoc ..... 3  
Wiring ..... 3  
Cruise Control Disconnect Wiring ..... 4  
EBP Valve & Final Wiring ..... 5  
DFIV Adjustment & Testing ..... 9  
Have any questions? ..... 9  
Ford Exhaust Brake RetroFit Kit (California Trucks) ..... 10  
Warranty Statement ..... 11

BD Engine Brake, Inc.

Plant Address: Unit A10, 33733 King Rd, Abbotsford, BC, Canada V2S 7M9

U.S. Shipping Address: #88-446 Harrison St, Sumas, WA 98295 U.S. Mailing Address: P.O. Box 231, Sumas, WA 98295

Phone: 604-853-6096 Fax: 604-853-8749 Internet: [www.bd-power.com](http://www.bd-power.com)

## Welcome

Thank you for purchasing the BD **BrakeLoc** Kit. This manual is to aid you with your installation and operation of the unit. We strongly suggest that you retain this manual for any future reference.

## The BD BrakeLoc Advantage

Though not as efficient as a **BD Exhaust Brake**, the **BrakeLoc** offers a cost effective solution of engine retarding for towing with the Ford PowerStroke by utilizing the OEM **Exhaust Back Pressure (EBP)** valve.

The **BD BrakeLoc** commands the **EBP valve** to activate. This allows the use of the Ford OEM stock **Exhaust Back Pressure Valve** to act as an engine brake.

## Operating the BD BrakeLoc

The **BrakeLoc** is controlled by a manual toggle switch and works off of the power signal from the throttle position sensor to activate the **EBP Valve** circuit allowing it to close, and, will only operate when the toggle switch is on AND the throttle pedal is at idle.

Once the toggle switch for the **1030755 BD BrakeLoc** is turned on, the kit monitors the accelerator pedal position for the signal that it is at the "idle" position. When this occurs, the kit will begin to activate the **EBP** valve, which after an approximately 3 second delay, you will feel and hear the **EBP Valve** apply.

When the accelerator pedal is applied or the toggle switch is turned off, the kit will disengage the **EBP** valve, allowing the EBP Valve to continue stock OEM operation.

## Wiring

**CAUTION: Before installing any wiring modifications or equipment ensure to disconnect the battery Ground (Negative) terminals on all vehicle batteries as damage to the vehicle's ECU and/or installed component may result.**

Remove lower section of dash, under the steering column, and mount the DFIV module to the cross member under the steering column. Connect the Black wire from the DFIV module to a good ground.

Using a Posi-Tap™ connector, attach the fused wire from the toggle switch to either one of the two Red w/Black tracer wires (ignition switched power) under the steering column.

Mount Toggle Switch in a convenient spot on the dash.

BD Engine Brake, Inc.

Plant Address: Unit A10, 33733 King Rd, Abbotsford, BC, Canada V2S 7M9

U.S. Shipping Address: #88-446 Harrison St, Sumas, WA 98295 U.S. Mailing Address: P.O. Box 231, Sumas, WA 98295

Phone: 604-853-6096 Fax: 604-853-8749 Internet: www.bd-power.com

Locate the Throttle Position Sensor (TPS) at the throttle pedal and, using a Posi-Tap connector, attach the **yellow** wire attached to the “**APPS**” terminal on the DFIV module to the grey w/white tracer wire on the TPS.

Ensure the **green** wire is connected to the “**COM**” terminal of the DFIV module and the **blue** wire is connected to the “**FORD**” terminal of the DFIV module. Connect the **pink** wire to the “**BRAKE**” terminal of the DFIV module.

Run the other end of the pink, blue and green wires through a grommet on the firewall making sure all wires are secure and away from moving objects and heat sources. Reinstall the lower dash cover.

### *Cruise Control Disconnect Wiring*

Consult the schematic on page 8 for proper connections and assistance in connecting wires.

Locate the Brake Applied Switch on the front of the master cylinder.

Expose the wiring approximately 3-6” from the switch. Cut the black w/yellow tracer wire, then strip both ends and attach a blue Posi-Lock™ connector.

Run the blue and green wires that were brought through the firewall and connect them to the connectors just attached to the Black wire w/Yellow tracer.

For 1999-2003 Powerstrokes, Run the pink wire that was brought through the firewall and tap into the EBP valve wiring harness using a black (14-18ga) or grey (18-22ga) Posi-Tap.

For 1994-1997 Powerstrokes, disconnect the EBP valve wiring harness connection (see page 8) and tee in the small harness supplied with this kit (1300742). Attach the female end of the EBP valve harness into the male end of the BrakeLoc harness, and attach the male end of the EBP valve harness into the female end of the BrakeLoc harness. Use the blue bullet connector supplied to attach the red wire coming off the tee harness to the **pink** wire attached to the “**BRAKE**” terminal of the DFIV module that was brought through the firewall.

## *EBP Valve & Final Wiring*

To gain access to the EBP Valve and wiring, remove the top intercooler hose and then remove the sensor hose and wire connector from the MAP sensor.

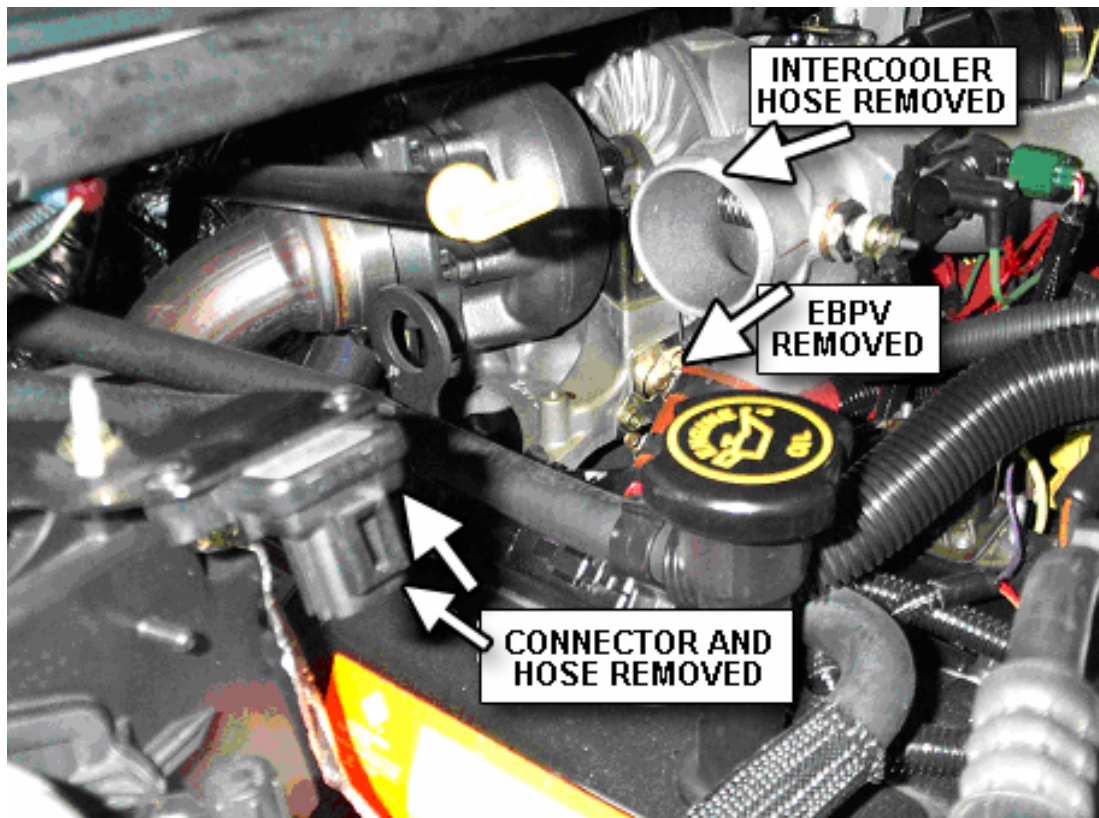
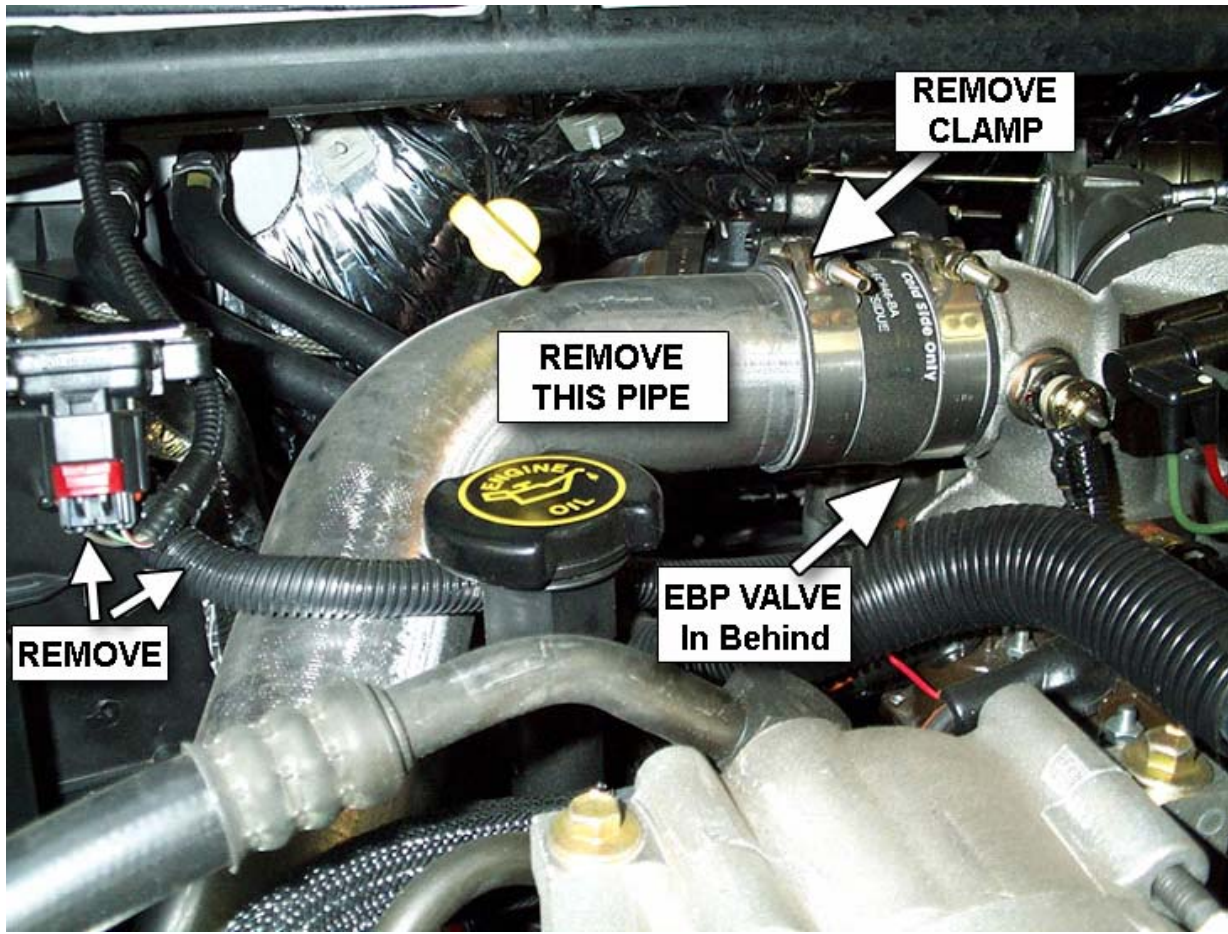

BD Engine Brake, Inc.

Plant Address: Unit A10, 33733 King Rd, Abbotsford, BC, Canada V2S 7M9

U.S. Shipping Address: #88-446 Harrison St, Sumas, WA 98295 U.S. Mailing Address: P.O. Box 231, Sumas, WA 98295

Phone: 604-853-6096 Fax: 604-853-8749 Internet: [www.bd-power.com](http://www.bd-power.com)

For ease of access and hook up, remove the connector from the EBP Valve and pull the wiring through and underneath to the front of the intake Y-plenum. This will allow access to install a Posi-Tap™ or Connector harness.

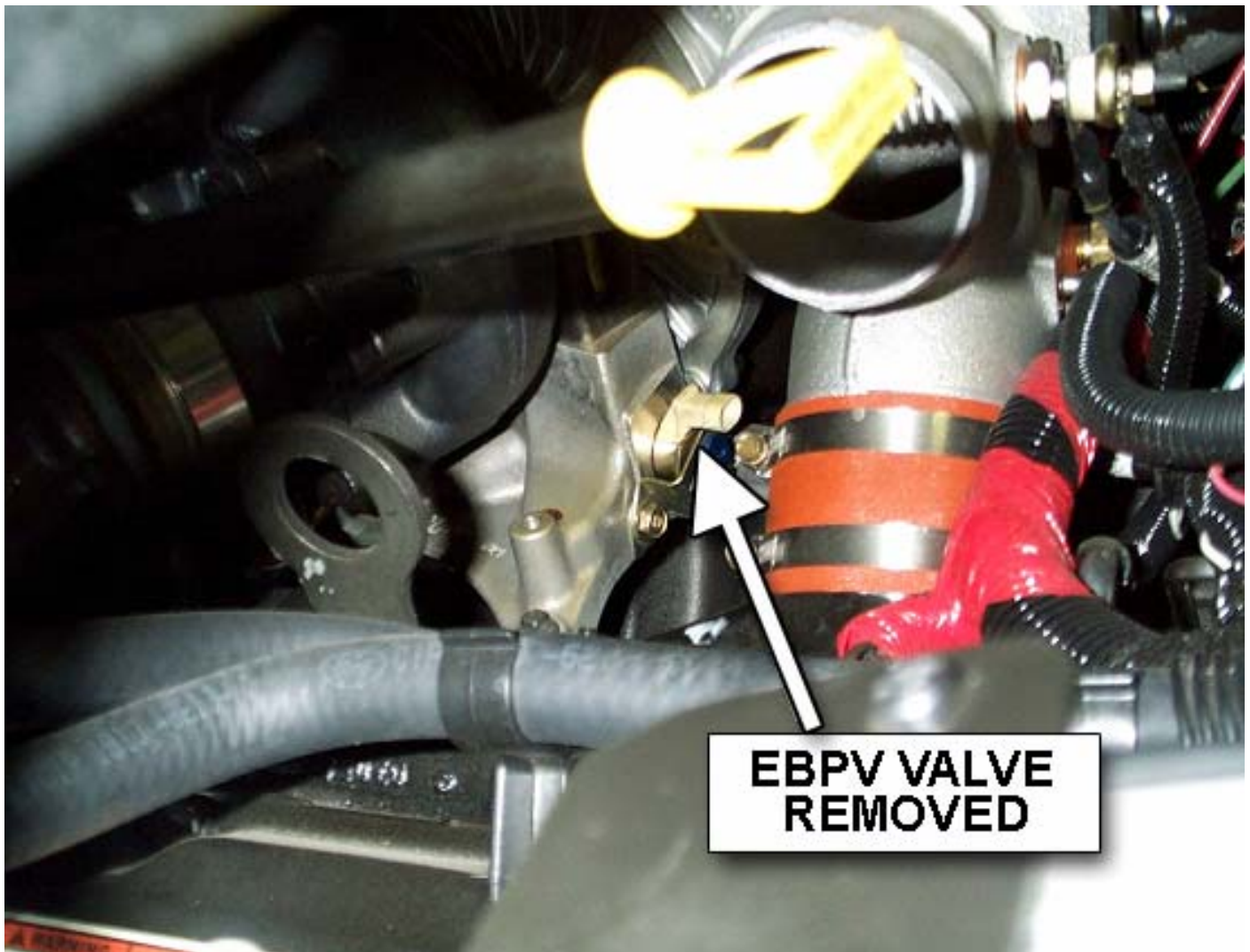

BD Engine Brake, Inc.

Plant Address: Unit A10, 33733 King Rd, Abbotsford, BC, Canada V2S 7M9

U.S. Shipping Address: #88-446 Harrison St, Sumas, WA 98295 U.S. Mailing Address: P.O. Box 231, Sumas, WA 98295

Phone: 604-853-6096 Fax: 604-853-8749 Internet: [www.bd-power.com](http://www.bd-power.com)

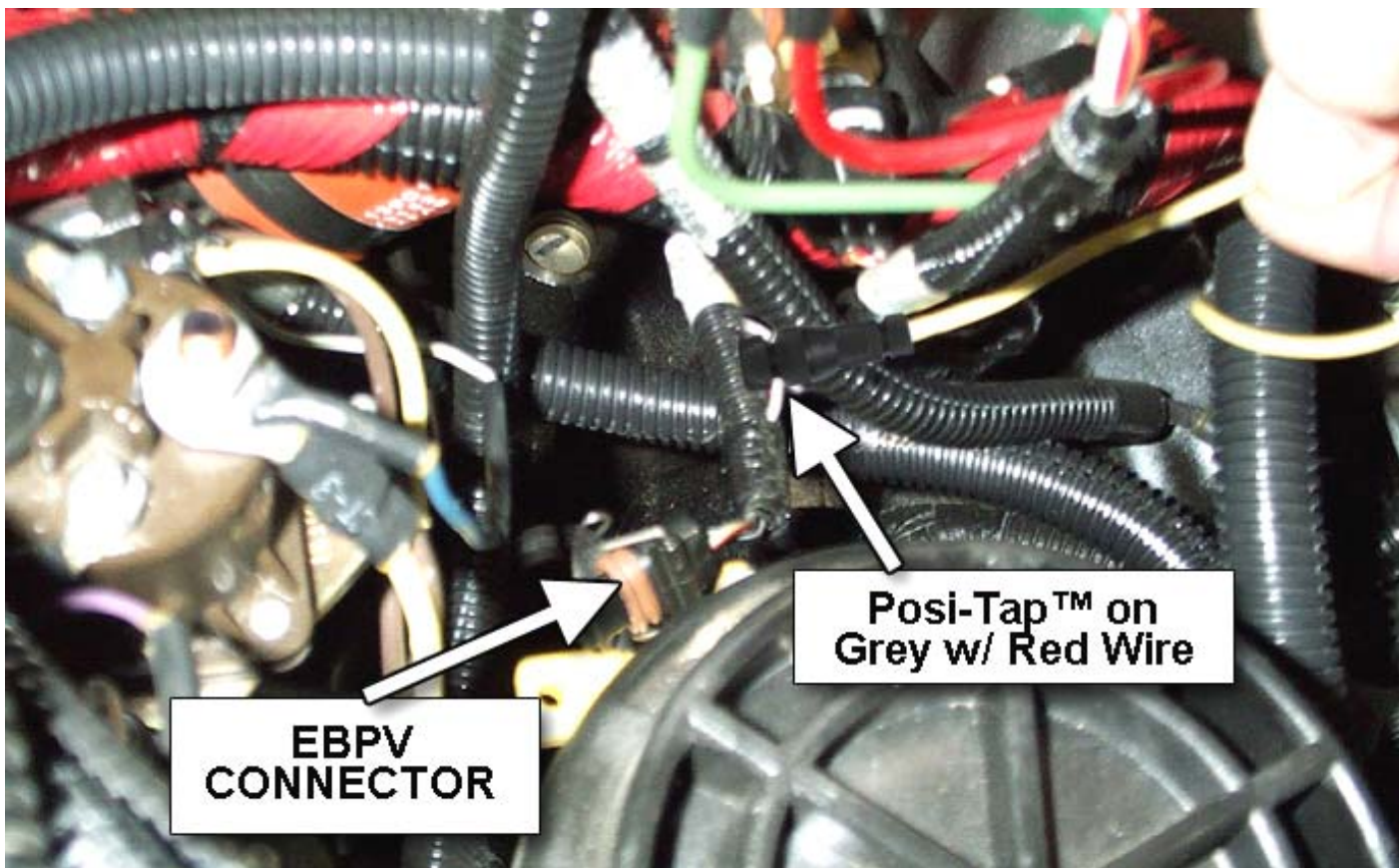

<p><u>FORD 1999-2003</u> <b>(7.3L)</b></p>	<p>Locate the wire harness at the EBP Valve and peel back the insulation to allow access to the wires. Locate and attach a Posi-Tap™ to the Grey w/Red tracer wire.</p> <p>Install the Gray wire to this connection.</p>
<p><u>FORD 1995-1997</u> <b>(7.3L)</b></p>	<p>Remove the wiring connector from the EBP Valve and install the Red wiring harness with a Posi-Tap™ connector. Then attach the other end of the Red wire to the end of the Gray wire.</p> <p>Reroute the EBP Valve electrical connector back underneath the intake Y-plenum and reinstall into the EBP Valve.</p>

**NOTE:** After installation, ensure to replace the intercooler hose and clamps. Reattach the MAP sensor hose and wiring connector. Check all connections for security and tightness and secure all wiring to ensure they are out of the way of moving and heated items.

Reconnect and secure all battery connections removed at the beginning of this installation.

# Wiring Diagram

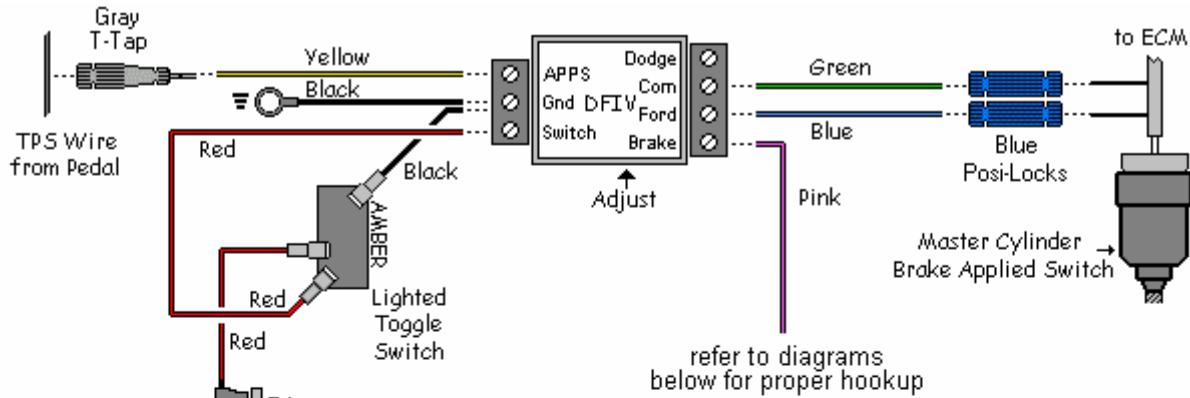

refer to diagrams below for proper hookup

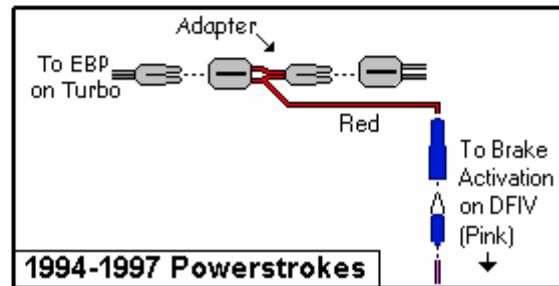
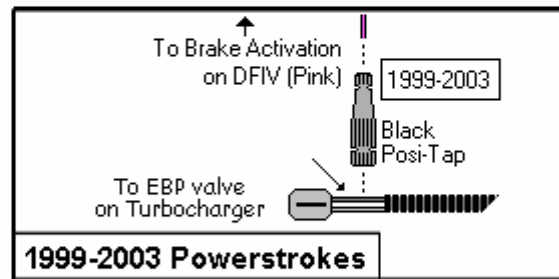

**NOTE:** After installation ensure to replace the intercooler hose and clamps. Reattach the MAP sensor hose and wiring connector. Check all connections for security and tightness and secure all wiring to ensure they are out of the way of moving and heated items.

Reconnect and secure all battery connections removed at the beginning of this installation.



## *DFIV Adjustment & Testing*

Ensure the connections of the corresponding wires to the DFIV Control Module are correct as shown in the wiring diagram.

To achieve the correct setting for the activation of the exhaust brake in relation to the throttle pedal the DFIV Module must be calibrated for your vehicle.

Connect a test light to the 'BRAKE' terminal of the DFIV module.

With the throttle at idle, start the engine and turn on brake switch. Then, using a small flat bladed screwdriver, turn the small adjusting screw in the DFIV Module counterclockwise or clockwise until the test light JUST turns on.



**CAUTION:** THE ADJUSTING SCREW IS A MICRO-SWITCH WHICH IS VERY DELICATE, SO TURN USING SMALL ADJUSTMENTS.

Test by revving up the engine to approximately 1200 RPM and releasing the throttle. As the accelerator pedal is applied the test light should turn off just before the engine starts to rev, indicating proper calibration of the DFIV Module with the APPS.

Then the test light should activate again when the throttle pedal returned to idle. If not, readjust the DFIV Module so that it does.

Check for any exhaust leaks and recheck all connections and hoses for security and interference from moving or heated items. After about 100 miles (160 km), re-torque the flange bolts.

## *Have any questions?*

Thank you for purchasing the BD BrakeLoc, please check out our web site at [www.bd-power.com](http://www.bd-power.com) for other performance products such as BD PressureLoc, BD Performance Chip or for info on our Performance Transmissions and components please call, fax or E-mail our **BD Technical Service or Sales Department**, 8:30am to 4:30pm Pacific Time, Monday to Friday.

BD Engine Brake, Inc.

Plant Address: Unit A10, 33733 King Rd, Abbotsford, BC, Canada V2S 7M9

U.S. Shipping Address: #88-446 Harrison St, Sumas, WA 98295 U.S. Mailing Address: P.O. Box 231, Sumas, WA 98295

Phone: 604-853-6096 Fax: 604-853-8749 Internet: [www.bd-power.com](http://www.bd-power.com)

## Ford Exhaust Brake Retrofit Kit (California Trucks)

The purpose of this kit is to cure the problematic Ford P-Code in regards to exhaust back pressure being too high. This code is normally set with California Powerstrokes when using an exhaust brake. This kit should only be used on California trucks that exhibit the problem.

To install, locate the Exhaust Back Pressure sensor at the front of the engine, just behind the idler pulley and to the left of the water pump outlet hose.

Install the supplied Posi-Tap™ connector on to the Violet with Light Blue wire (2000 – 03) or the Pink with Light Blue wire (1999).

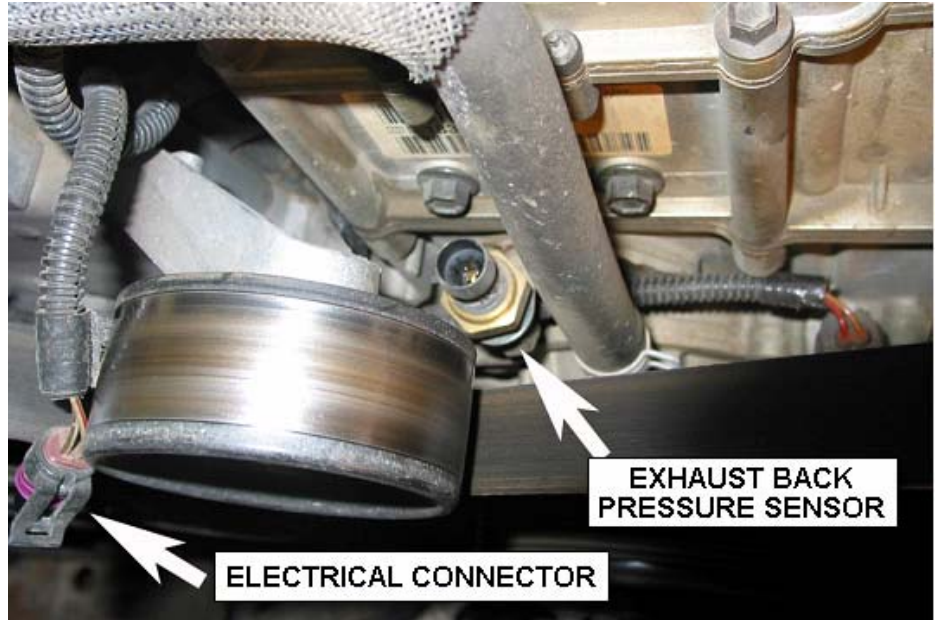

Connect the black wire pigtail to the Posi-Tap™ connector using the male blade connector. Run the remaining wire away from the belt and the pulley and use the nearest engine bolt as a ground.

**Do not cut or shorten the supplied wire. There is a diode located inside of it.**

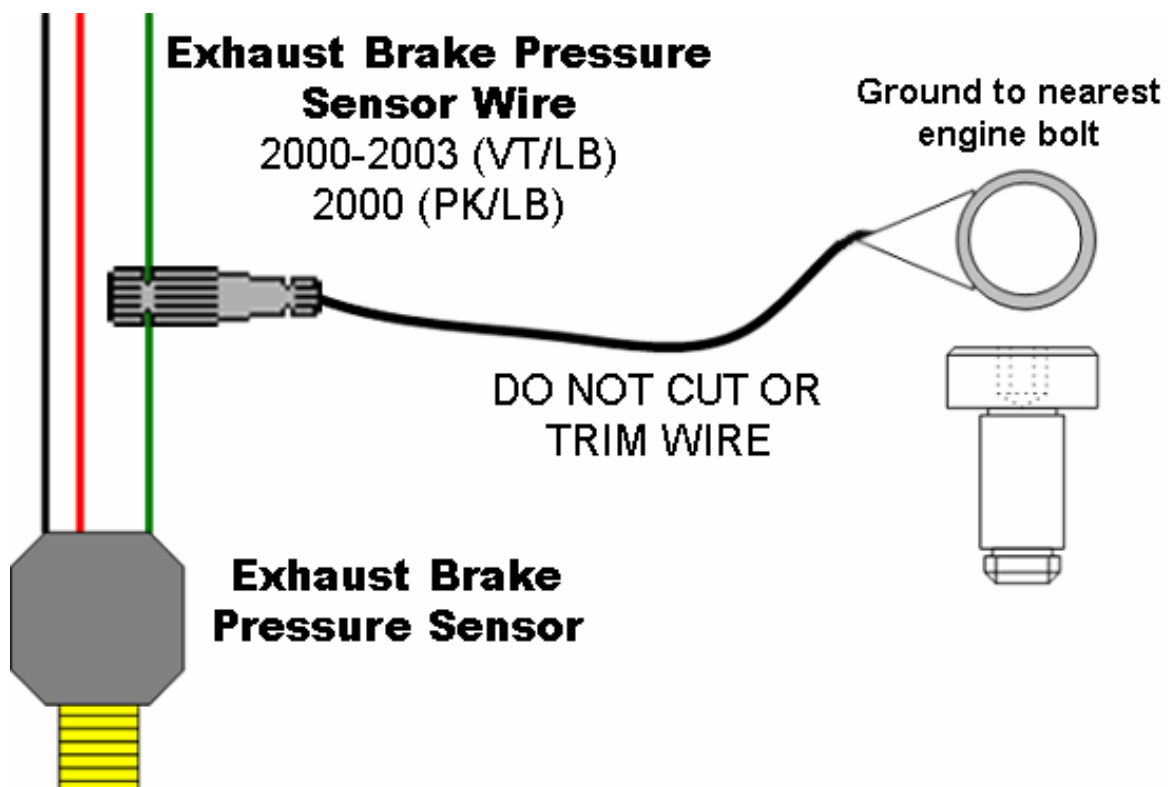

BD Engine Brake, Inc.

Plant Address: Unit A10, 33733 King Rd, Abbotsford, BC, Canada V2S 7M9

U.S. Shipping Address: #88-446 Harrison St, Sumas, WA 98295 U.S. Mailing Address: P.O. Box 231, Sumas, WA 98295

Phone: 604-853-6096 Fax: 604-853-8749 Internet: [www.bd-power.com](http://www.bd-power.com)

## BD Engine Brake, Inc. *Warranty Statement*

BD Engine Brake, Inc. (BD) warrants to the original purchaser that any parts purchased shall be free from defects in material workmanship. A defect is defined as a condition within the product that would render the product inoperable. BD limits the liability to the repair or replacement, at BD's option, of any warrantable product, returned prepaid with a complete service history and proof of purchase to the factory. A valid proof of purchase is a dated bill of sale. Repaired or replaced product will be returned to the customer freight collect. Accepted warranty units, which have been replaced, become the sole property of BD.

A Return Material Authorization (RMA) number obtained in advance from a BD customer service representative must accompany product returned for warranty determination. BD will be the final authority on all warranty decisions.

This warranty shall not apply to any unit that has been improperly stored or installed; or to misapplication, improper operation conditions, accidents, or neglect, or which has been improperly repaired or altered or otherwise mistreated by the owner or his agent.

**This parts warranty shall terminate at the end of 12 months in service with the original user. Labor costs incurred by the removal and replacement of the BD product, while performing warranty work, will be covered for 12 months at authorized centers with prior approval. Until the product has been approved at the original installing dealer or at one of our distributors, the consumer should be responsible for these costs.**

Except as set forth in our parts outline, BD disclaims any implied warranties of merchantability and fitness for a particular purpose. **BD also disclaims any liability for incidental or consequential damages including but not limited to, repair labor, rental vehicles, hotel cost or any other inconvenience costs.** This warranty is in lieu of all other warranties or guaranties, either expressed or implied, and shall not extend to any consumer or to any person other than the original purchaser residing within the boundaries of the continental U.S. or Canada.

BD Engine Brake, Inc.

Plant Address: Unit A10, 33733 King Rd, Abbotsford, BC, Canada V2S 7M9

U.S. Shipping Address: #88-446 Harrison St, Sumas, WA 98295 U.S. Mailing Address: P.O. Box 231, Sumas, WA 98295

Phone: 604-853-6096 Fax: 604-853-8749 Internet: [www.bd-power.com](http://www.bd-power.com)