



# **BD Cool Down Timer 2**

## **Application Chart --**

<b><u>1081160</u></b>	Dodge Cummins (5.9/6.7)	<b>1994-2005</b>
	Ford F Series (6.0/6.4/7.3L)	<b>1994-2008</b>
	GMC/Chevy Duramax	<b>2001-2009</b>
<b><u>1081160-D1</u></b>	Dodge Cummins (5.9/6.7)	<b>2006-2009</b>
<b><u>1081160-D2</u></b>	Dodge Cummins (6.7)	<b>2010-2012</b>

**\*\*\* Please read this manual before starting installation. \*\*\***

**OWNER'S MANUAL - LEAVE IN GLOVE BOX**

Install Manual Part # I1081160

Printed in Canada

BD Engine Brake Inc.

Plant Address: 33541 MacLure Rd. Abbotsford, BC, Canada V2S 7W2

U.S. Shipping Address: 88-446 Harrison St, Sumas, WA 98295 U.S. Mailing Address: P.O. Box 231, Sumas, WA 98295

Phone: 604-853-6096 | Fax: 604-853-8749 | Internet: [www.bd-power.com](http://www.bd-power.com)

# **TABLE OF CONTENTS**

<b>Kit Contents</b> .....	<b>3</b>
Required Tools.....	4
Options.....	4
Compatibility .....	4
<b>Notes On Connectors</b> .....	<b>5</b>
<b>What Is The Cool Down Timer 2 (CDT2)?</b> .....	<b>5</b>
<b>How Does The Cool Down Timer 2 Work?</b> .....	<b>6</b>
<b>Precautions</b> .....	<b>6</b>
<b>Safety Features</b> .....	<b>7</b>
<b>Vehicle Wiring</b> .....	<b>7</b>
<b>NOTES</b> .....	<b>8</b>
<b>GENERAL WIRING</b> .....	<b>8</b>
<b>FORD POWERSTROKE WIRING DIAGRAM</b> .....	<b>9</b>
<b>DODGE CUMMINS WIRING DIAGRAM</b> .....	<b>12</b>
<b>2004½ - 2005 Dodge Trucks Wastegate Solenoid Power Wiring</b> .....	<b>13</b>
<b>Dodge 2006-2009</b> .....	<b>14</b>
<b>Dodge 2010-2012</b> .....	<b>15</b>
<b>DURAMAX WIRING DIAGRAMS</b> .....	<b>16</b>
<b>Thermocouple Wiring (Not needed if monitoring with Time vs. Temp)</b> .....	<b>19</b>
Direct Thermocouple Connection .....	19
Amplified Pyrometer Gauge Kit .....	19
Conventional Non-Amplified Pyrometer Kit .....	20
<b>Temperature Adjustment</b> .....	<b>20</b>
<b>Time Adjustment</b> .....	<b>21</b>
<b>Communication / Operation Lights</b> .....	<b>22</b>
<b>Mounting</b> .....	<b>22</b>
<b>Technical Assistance</b> .....	<b>22</b>
<b>Wire Color Glossary</b> .....	<b>23</b>
<b>Troubleshooting</b> .....	<b>24</b>

BD Engine Brake Inc.

Plant Address: 33541 MacLure Rd. Abbotsford, BC, Canada V2S 7W2







U.S. Shipping Address: 88-446 Harrison St, Sumas, WA 98295 U.S. Mailing Address: P.O. Box 231, Sumas, WA 98295

Phone: 604-853-6096 | Fax: 604-853-8749 | Internet: [www.bd-power.com](http://www.bd-power.com)

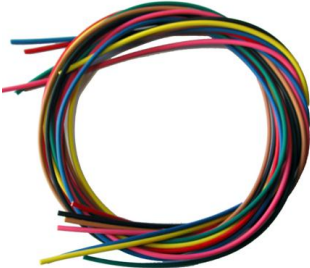
# Kit Contents

Please check to make sure that you have all the parts listed in this kit before you begin to install this kit.

## BD Cool Down Timer 2 (P/N# 1081160)

1801160	1801161	1300131	
			
<p><i>CDT2 Control Module</i></p>	<p><i>CDT2 Wiring Harness</i></p>	<p><i>Cable Tie (Medium)</i></p>	
<p><b>Qty: 1</b></p>	<p><b>Qty: 1</b></p>	<p><b>Qty: 10</b></p>	
1300348	1300349	1300350	1801151
			
<p><i>Posi-Tap Connector (18-22ga – Red in color)</i></p>	<p><i>Posi-Tap Connector (12-18ga – Black in color)</i></p>	<p><i>Posi-Tap Connector (10-12ga – Yellow in color)</i></p>	<p><i>Ring Connector</i></p>
<p><b>Qty: 5</b></p>	<p><b>Qty: 2</b></p>	<p><b>Qty: 2</b></p>	<p><b>Qty: 2</b></p>

BD Engine Brake Inc.

Plant Address: 33541 MacLure Rd. Abbotsford, BC, Canada V2S 7W2



U.S. Shipping Address: 88-446 Harrison St, Sumas, WA 98295 U.S. Mailing Address: P.O. Box 231, Sumas, WA 98295

Phone: 604-853-6096 | Fax: 604-853-8749 | Internet: www.bd-power.com

**DODGE 2006-2009 (P/N# 1081160-D1)**

1801160	1801162-1	1300348	1300131
			
CDT2 Control Module	2006-09 Harness	Posi-Tap Connector (Red)	Cable Tie (Medium)
Qty: 1	Qty: 1	Qty: 1	Qty: 5

**DODGE 2010-2012 (P/N# 1081160-D2)**

1801160	1801162-2	1300131
		
CDT2 Control Module	2010-2012 Harness	Cable Tie (Medium)
Qty: 1	Qty: 1	Qty: 5

**Required Tools**

- Wire strippers
- Wire crimpers
- Small Flat Nose Screwdriver
- Philips Screwdriver
- Pliers (Needle / Flat Nose)
- Soldering Gun (Optional)
- Heat Shrink / Liquid Tape (Optional)

**Options**

- 1081151 Probe (Thermocouple) Kit

**Compatibility**

This Cool Down Timer will work with virtually all "K" type of thermocouples offered by companies such as ISSPRO or EGT.

BD Engine Brake Inc.

Plant Address: 33541 MacLure Rd. Abbotsford, BC, Canada V2S 7W2

U.S. Shipping Address: 88-446 Harrison St, Sumas, WA 98295 U.S. Mailing Address: P.O. Box 231, Sumas, WA 98295

Phone: 604-853-6096 | Fax: 604-853-8749 | Internet: www.bd-power.com

## Notes On Connectors

The kit includes a number of Posi-Tap™ connectors (Gray or Red/Black/Green or Yellow) to tap onto OEM wiring. It is important to select the correct color of connector so that it matches the gauge of the OEM wire that it is being installed on. Using the incorrect connector could cause an inadequate connection and/or the OEM wire could be severed.

OEM Wire	Posi-Tap™ Color
18-22ga	Gray
12-18ga	Black
10-12ga	Yellow

Though these connectors offer a quicker installation, the best option would be to solder the wires and isolate the joints with heat shrink or liquid electrical tape. Proper soldering techniques should be used to ensure adequate connections.

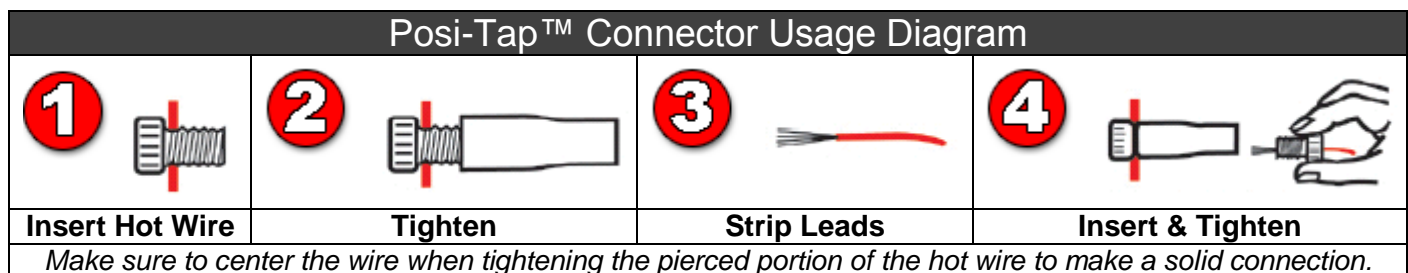

The ground terminals of the vehicle's batteries should be disconnected before performing any piercing/posi-tapping onto any ECM/PCM wire.

## What Is The Cool Down Timer 2 (CDT2)?

The CDT2 is designed to keep the engine running when the ignition key is turned off and the exhaust temperature is above a set point (between 250-550°F) to prevent turbocharger bearing failure that could occur when the engine is shut down too quickly.

A typical turbocharger can spin in excess of 100,000rpm under load, which will continue spinning when the engine is turned off.

The turbocharger is lubricated and cooled by the engine oil, and when the engine is turned off, that oil supply is cut off. If a turbocharger is still spinning at a high RPM when the oil supply is cut off, the internal bearings will utilize what remaining oil is around them then start to heat up - essentially cooking the oil, which causes premature bearing failure. By allowing the turbocharger to slow down to a safe RPM, this bearing failure can be prevented.

A very efficient means of gauging a safe time to turn the engine off is by the exhaust temperature. The suggested temperature range to go by is below 400°F (with the thermocouple mounted post-turbo). The further away the probe is away from the turbocharger, the lower the shut-off temperature should be. If the thermocouple is mounted pre-turbo, then the shut-off temperature can be higher.

BD Engine Brake Inc.

Plant Address: 33541 MacLure Rd. Abbotsford, BC, Canada V2S 7W2

U.S. Shipping Address: 88-446 Harrison St, Sumas, WA 98295 U.S. Mailing Address: P.O. Box 231, Sumas, WA 98295

Phone: 604-853-6096 | Fax: 604-853-8749 | Internet: www.bd-power.com

## ***How Does The Cool Down Timer 2 Work?***

The CDT2 module utilizes the signal from the thermocouple that is measuring the exhaust gas temperature. The thermocouple may already be connected to a gauge or it can be connected to the CDT2 module on its own.

When the key is turned off and the exhaust gas temperature is above the shutdown setting, the CDT2 module will keep power supplied to the ECM/PCM, which in turn will keep the engine running until the temperature falls below the setting.

As well a new feature of the CDT2 is to shut the truck down based on an adjustable time. This time is adjustable using the potentiometer on the side of the control unit.

## ***Precautions***

The CDT2 by default will **not** lock the doors or set the alarm. With most vehicles, once you shut the door you can use the keyless remote or key to lock the doors.

Most OEM and aftermarket alarms will have to be activated after the CDT2 has shutdown the engine. Due to the wide variety of the alarms and immobilizers, it is best to test the system(s) thoroughly to ensure proper procedures of activation or use in conjunctions with the CDT2.

The “Relay Output (NO)” and the “Relay Common” terminals can be configured to lock the doors automatically. Depending on the vehicle and the method of locking the doors you can wire either a Ground or 12V source to the “Relay Common” terminal. When the CDT2 shuts down the “Relay Common” terminal will be pulsed out to the “Relay Output (NO) terminal. See the below wiring diagram. Note BD cannot provide support on this option.

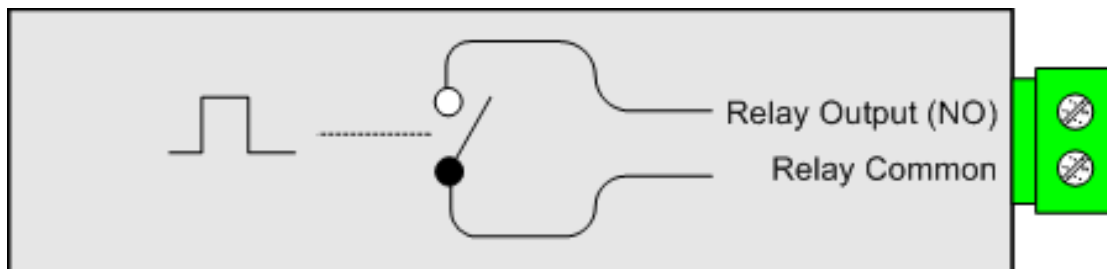

Proper parking procedures should be adhered to before leaving the vehicle including the engagement of the parking brake. Children or animals should not be left unattended in the vehicle while the CDT2 is keeping the vehicle running.

BD Engine Brake Inc.

Plant Address: 33541 MacLure Rd. Abbotsford, BC, Canada V2S 7W2

U.S. Shipping Address: 88-446 Harrison St, Sumas, WA 98295 U.S. Mailing Address: P.O. Box 231, Sumas, WA 98295

Phone: 604-853-6096 | Fax: 604-853-8749 | Internet: [www.bd-power.com](http://www.bd-power.com)

## ***Safety Features***

The CDT2 module has a few safety features built-in that the driver should be aware of. If for some reason the exhaust gas temperature does not fall below the shutdown setting within five (5) minutes from the key being turned off, the CDT2 will automatically shutdown the engine.

As well if the engine starts to initiate a REGEN cycle causing the EGT's to rise the CDT2 will shut the truck off.

The CDT2 module is also designed to monitor the vehicle's hydraulic brakes when it is connected to the brake pedal switch via the Brake Pedal terminal on the module. While the CDT2 module is keeping the engine alive (ignition key turned off and exhaust gas temperature above the shutdown setting), if the brake pedal is depressed the CDT2 will shutdown the engine. This was implemented to protect the vehicle from being stolen when the engine is in cool down mode; eventually the brake pedal would have to be pressed which will shutdown the engine preventing the thief from easily driving away with the vehicle. This is also useful in situations where the engine needs to be shutdown immediately or is desired to be shutdown sooner.

## ***Vehicle Wiring***

Using the following diagrams applicable to your vehicle, tap onto the vehicles wires using the appropriate sized Posi-Tap™ connector (not necessary if soldering the connections). All the vehicle wires are located under the dash where the module will be located.

Excess wire can be trimmed but please keep in mind that the module may have to be accessed to adjust the shutdown temperature so we suggest leaving enough slack to perform this function.

Connect to the appropriate terminals as per the charts and diagrams. Tighten each terminal by turning the terminal screws clockwise until the wire is secure.

When connecting the wires to the module, leave enough slack to so that the module can be accessed to temperature adjustments.

BD Engine Brake Inc.

Plant Address: 33541 MacLure Rd. Abbotsford, BC, Canada V2S 7W2

U.S. Shipping Address: 88-446 Harrison St, Sumas, WA 98295 U.S. Mailing Address: P.O. Box 231, Sumas, WA 98295

Phone: 604-853-6096 | Fax: 604-853-8749 | Internet: [www.bd-power.com](http://www.bd-power.com)

# NOTES

Please be advised that when the engine is in cool down mode (CDT2 is active) a number of trouble lights or message center errors maybe displayed. This is completely normal and should not be a concern. The vehicle will function normally once the key is inserted again.

# GENERAL WIRING

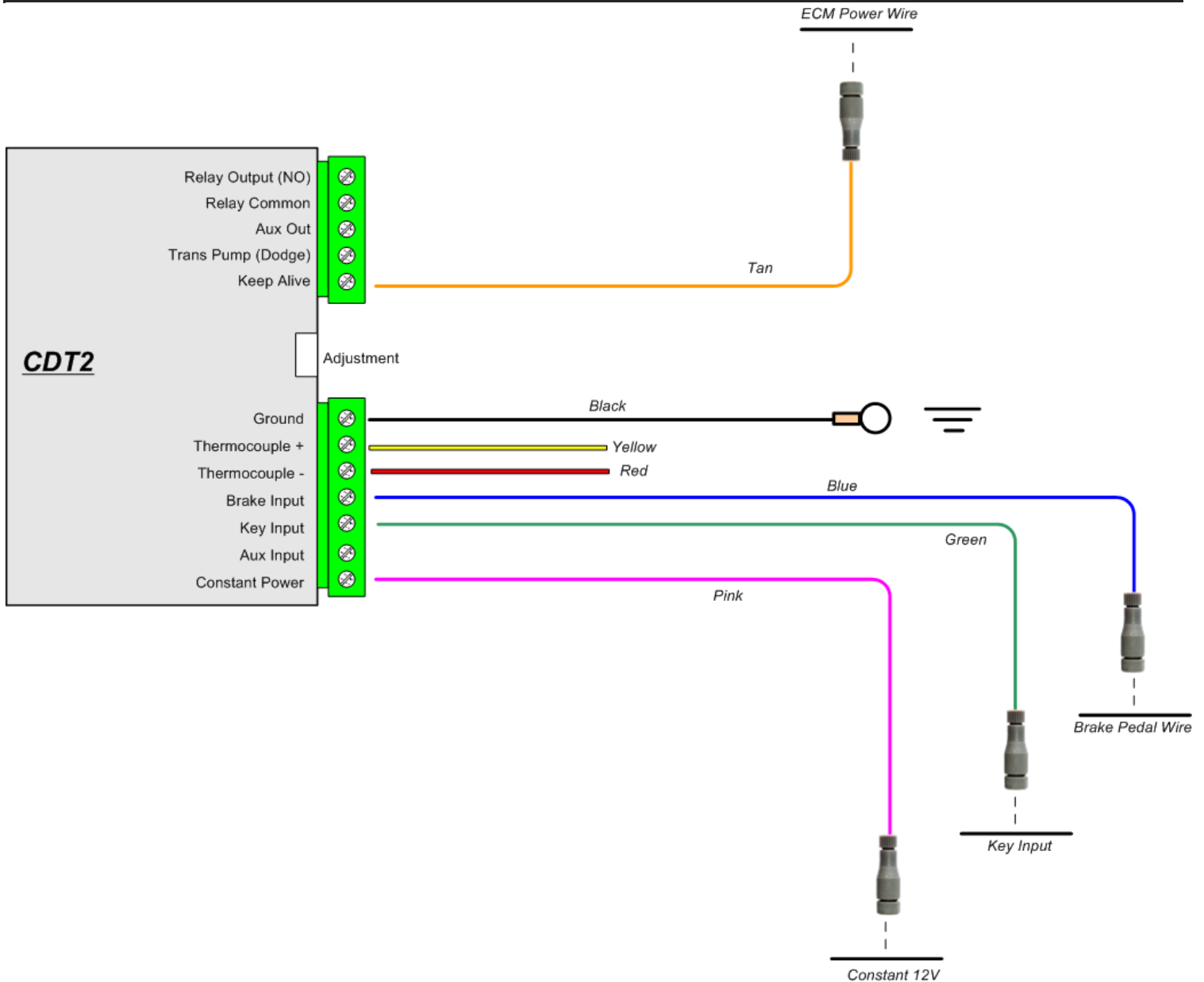

BD Engine Brake Inc.

Plant Address: 33541 MacLure Rd. Abbotsford, BC, Canada V2S 7W2

U.S. Shipping Address: 88-446 Harrison St, Sumas, WA 98295 U.S. Mailing Address: P.O. Box 231, Sumas, WA 98295

Phone: 604-853-6096 | Fax: 604-853-8749 | Internet: www.bd-power.com



# FORD POWERSTROKE WIRING DIAGRAM

## Steering Column

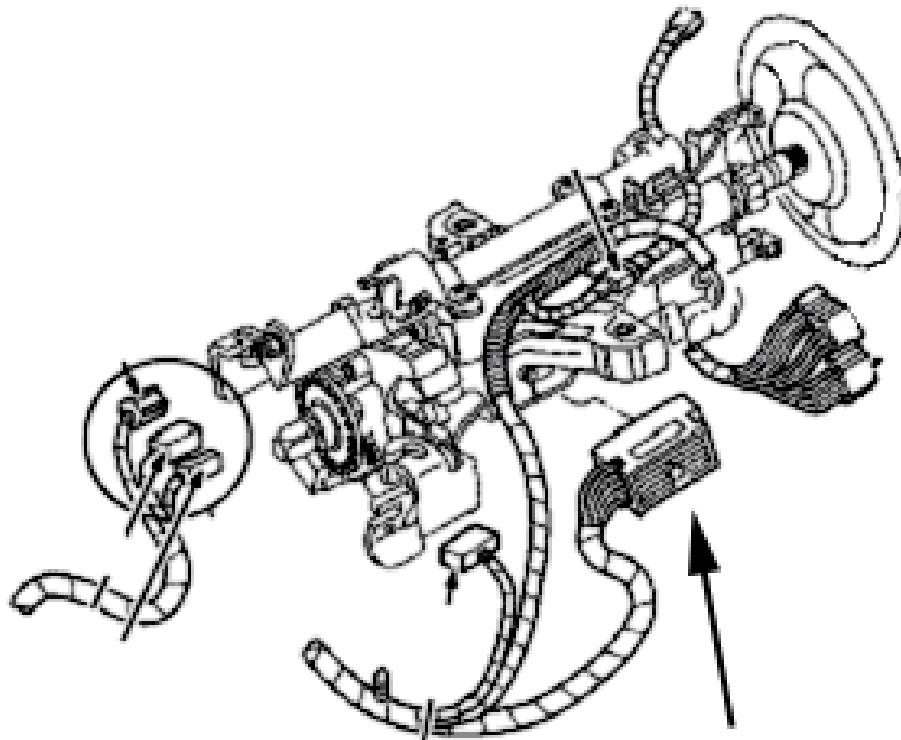

**Ignition Switch  
(11572)**

**1994-2004 Fords**

**2005-2007 Fords**

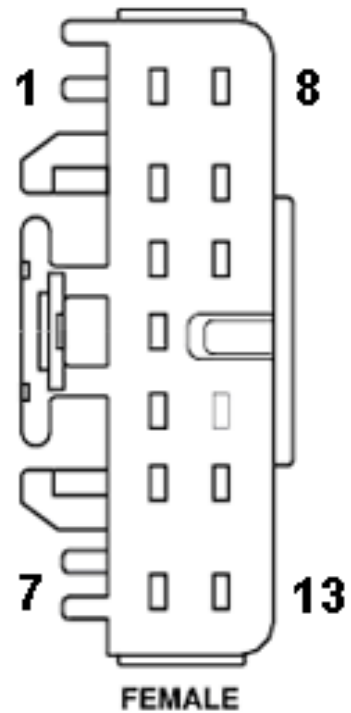
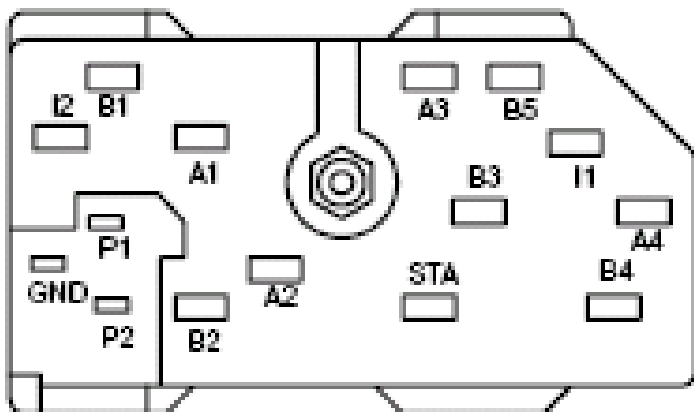

BD Engine Brake Inc.

Plant Address: 33541 MacLure Rd. Abbotsford, BC, Canada V2S 7W2

U.S. Shipping Address: 88-446 Harrison St, Sumas, WA 98295 U.S. Mailing Address: P.O. Box 231, Sumas, WA 98295

Phone: 604-853-6096 | Fax: 604-853-8749 | Internet: www.bd-power.com

### 2008-2010 Fords

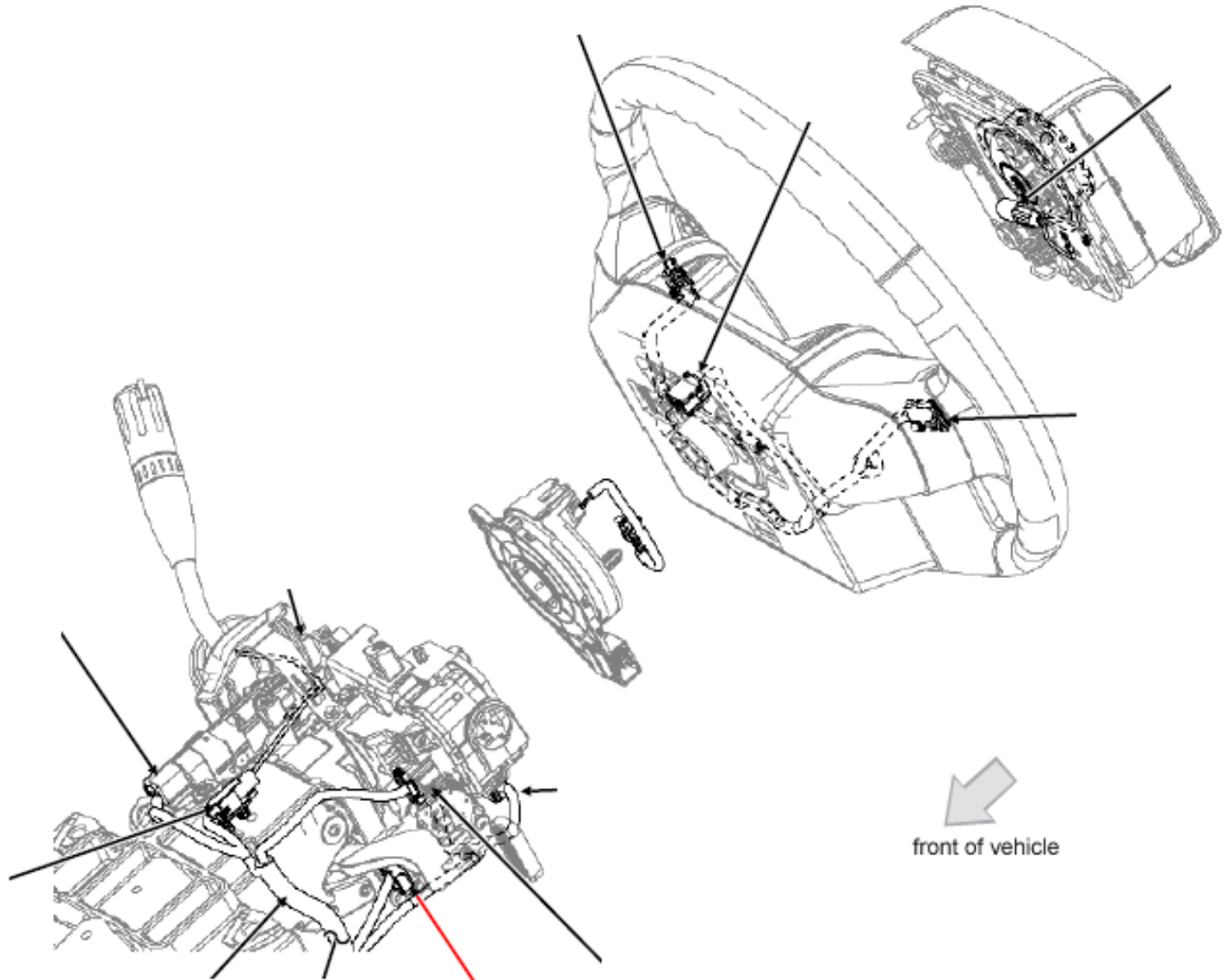

**C250  
Ignition  
switch**

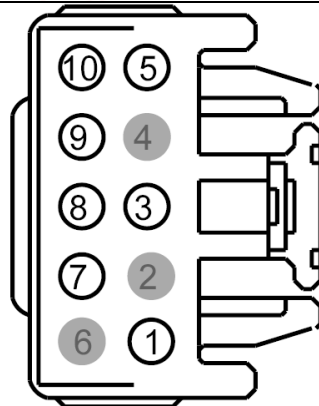

BD Engine Brake Inc.

Plant Address: 33541 MacLure Rd. Abbotsford, BC, Canada V2S 7W2

U.S. Shipping Address: 88-446 Harrison St, Sumas, WA 98295 U.S. Mailing Address: P.O. Box 231, Sumas, WA 98295

Phone: 604-853-6096 | Fax: 604-853-8749 | Internet: [www.bd-power.com](http://www.bd-power.com)

**Connect the black wire to a good grounding point.**

Model	Location	OEM Wire	Pin
<b>Brake Pedal (Blue Wire)</b>			
1994-2003 7.3L	Brake Pedal Switch	GN	
2003-2007 6.0L		RD/GN	
2008-2010 6.4L		VT/WH	
<b>Key (Green Wire)</b>			
1994-1997 7.3L	Ignition Connector C269	BK/LG 297	A1
1999-2003 7.3L		RD/BK 1040	A3
2003-2004 6.0L	Ignition Connector C250	RD/BK 1040	A3
2005-2007 6.0L		RD/BK 1040	13
2008-2010 6.4L		BR/YE or YE/OG	7
<b>Keep Alive (Tan Wire)</b>			
1994-1997 7.3L	Ignition Switch Harness	RD/LG 16	I1
1999-2001 7.3L		RD/BK 1000	I1
2002-2003 7.3L		RD/LG 16	I1
2003-2004 6.0L	Ignition Connector C250	WH/YL 1044	I1
2005-2007 6.0L		RD/LG 16	1
2008-2010 6.4L		WH/OG	1
<b>Constant (Pink Wire)</b>			
1994-2003 7.3L	Ignition Switch Harness	YL 37	B1 or B3
2003-2004 6.0L	Ignition Connector C250	YL 37	B1 or B3
2005-2007 6.0L		YL 37	7
2007-2010 6.4L		DB/RD	8

BD Engine Brake Inc.

Plant Address: 33541 MacLure Rd. Abbotsford, BC, Canada V2S 7W2

U.S. Shipping Address: 88-446 Harrison St, Sumas, WA 98295 U.S. Mailing Address: P.O. Box 231, Sumas, WA 98295

Phone: 604-853-6096 | Fax: 604-853-8749 | Internet: www.bd-power.com

# DODGE CUMMINS WIRING DIAGRAM

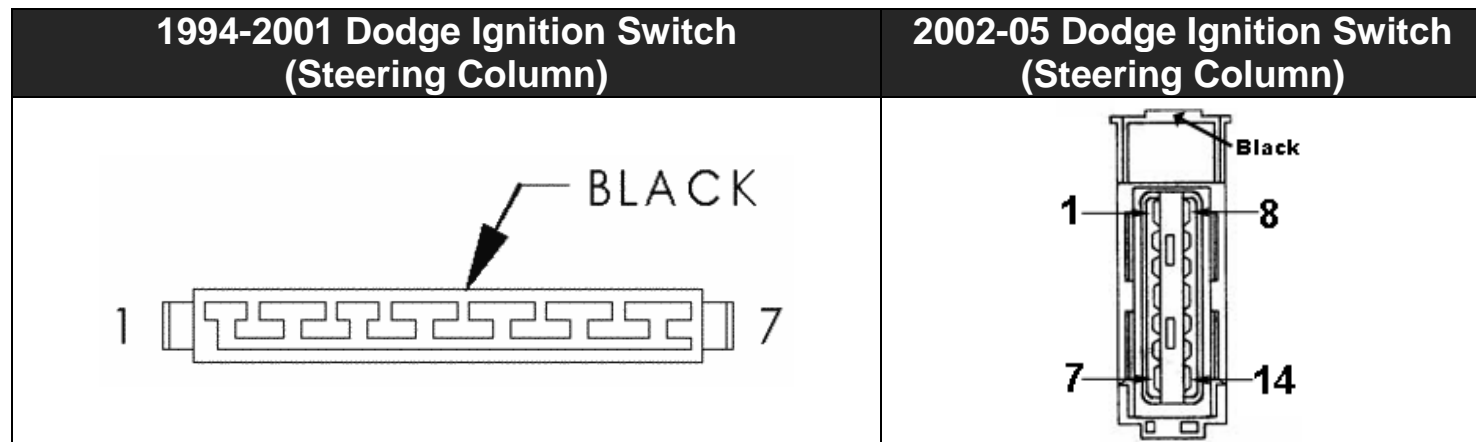

Model	Location	OEM Wire	Pin #
<b>Brake Pedal (Blue Wire)</b>			
1994-2001	Brake Pedal Switch	WT/TN L50	5
2002-2009		WT/TN L50	2
<b>Key (Green Wire)</b>			
1994-2002	Ignition Switch Harness	BK/OR A22	5
2003		BK/WT A31	9
2004-2005		PK/YL F982	9
<b>Keep Alive (Tan Wire)</b>			
1994-2002	Ignition Switch Harness	DB A21	2
2003		DB A21	3
2004-2005		PK/LG F951	3
<b>Constant (Pink Wire)</b>			
1994-2002	Ignition Switch Harness	RD A1	7
2003		RD A1	4
2004-2005		RD A951	4

BD Engine Brake Inc.

Plant Address: 33541 MacLure Rd. Abbotsford, BC, Canada V2S 7W2

U.S. Shipping Address: 88-446 Harrison St, Sumas, WA 98295 U.S. Mailing Address: P.O. Box 231, Sumas, WA 98295

Phone: 604-853-6096 | Fax: 604-853-8749 | Internet: www.bd-power.com

## 2004½ - 2005 Dodge Trucks Wastegate Solenoid Power Wiring

Dodge trucks in the year 2004½ & 2005 have a waste gate solenoid that requires power when the CDT2 keeps the ECM alive in cool down mode. You may notice that the check engine light comes on (with codes P0480 & P0243) approximately 30 seconds after the key is turned off.

The codes being set do not affect performance or drivability in any way but only causes the annoyance of the engine light coming on. See the diagram below and on the next page for reference.

This step is **not** required for 2006 and newer Dodge trucks.

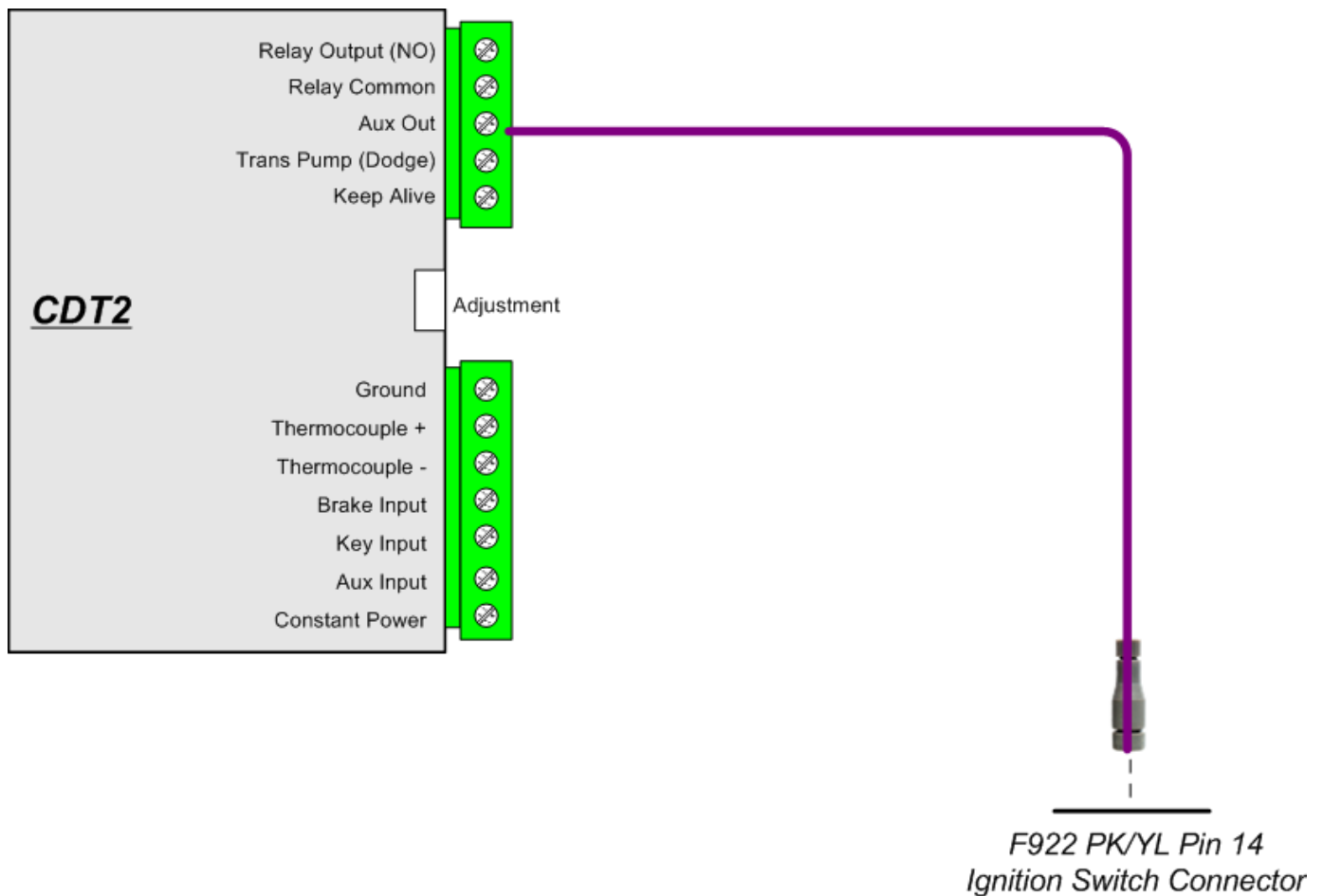

## Dodge 2006-2009

1. Record radio settings and disconnect the negative terminal from both batteries.

2. Remove the knee bolster and upper and lower steering column covers.

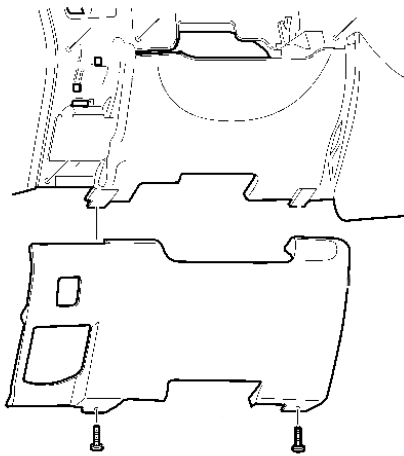

**Knee Bolster**

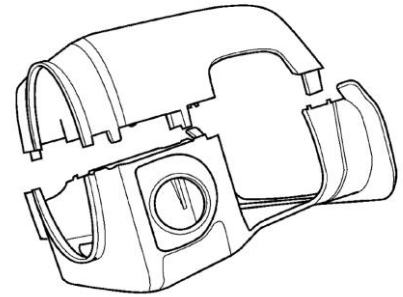

**Steering Column Covers**

3. Disconnect ignition switch connector. Then connect the CDT harness to the ignition switch connectors.
4. Connect blue brake switch wire to the WT/TN wire on the brake pedal switch. **(see table on page 12 above for details)**
5. Secure module away from pedals. Route wires to module and connect using the general wiring diagram on page 8 in this manual.
6. Reinstall knee bolster and steering column covers.
7. Reconnect batteries and test for functionality.

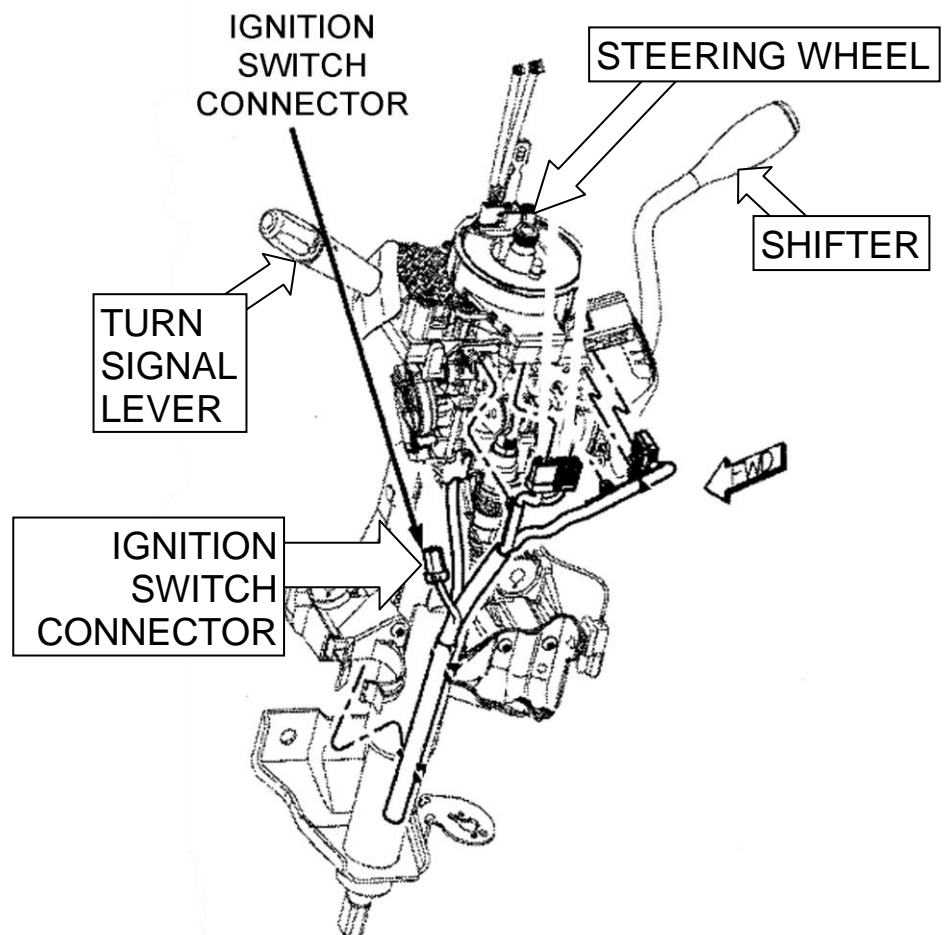

BD Engine Brake Inc.

Plant Address: 33541 MacLure Rd. Abbotsford, BC, Canada V2S 7W2

U.S. Shipping Address: 88-446 Harrison St, Sumas, WA 98295 U.S. Mailing Address: P.O. Box 231, Sumas, WA 98295

Phone: 604-853-6096 | Fax: 604-853-8749 | Internet: [www.bd-power.com](http://www.bd-power.com)

**Dodge 2010-2012**

1. Record radio settings and disconnect the negative terminal from both batteries.

2. Remove knee bolster.

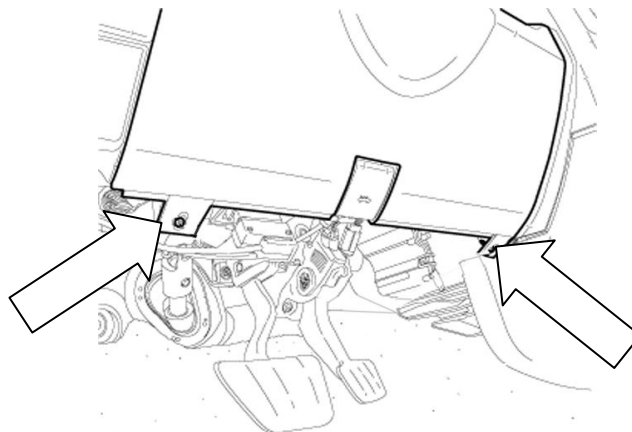

3. Disconnect ignition switch connector and plug CDT harness inline.
4. Mount module securely away from pedals. Route wires to module and connect wires using the general wiring diagram on page 8 in this manual.
5. Reinstall knee bolster.
6. Reconnect batteries and test for functionality.

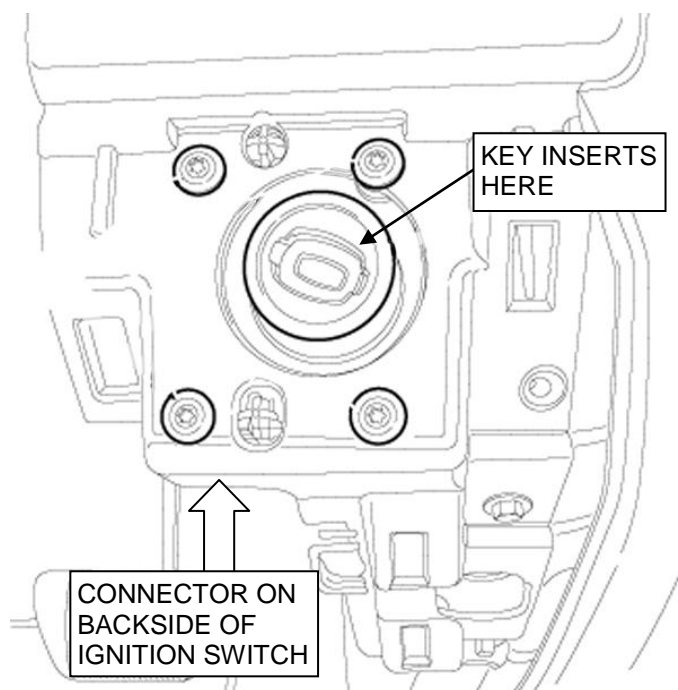

BD Engine Brake Inc.

Plant Address: 33541 MacLure Rd. Abbotsford, BC, Canada V2S 7W2

U.S. Shipping Address: 88-446 Harrison St, Sumas, WA 98295 U.S. Mailing Address: P.O. Box 231, Sumas, WA 98295

Phone: 604-853-6096 | Fax: 604-853-8749 | Internet: [www.bd-power.com](http://www.bd-power.com)

# DURAMAX WIRING DIAGRAMS

## Duramax Ignition Connector Location

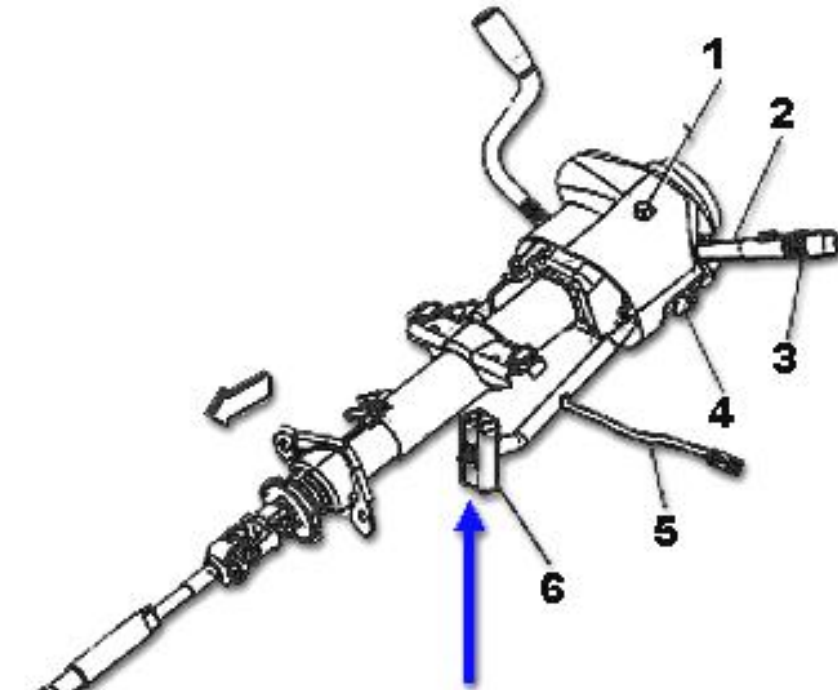

### Legend

- 1. Hazard Button
- 2. Multi-Function Lever
- 3. Cruise Control Switches
- 4. Tilt Steering Actuator
- 5. Inflatable Restraint Harness
- 6. 201 Inline Connector

**Connect the black wire to a good grounding point.**

## 2001-2002 Duramax Ignition Connector (C201)

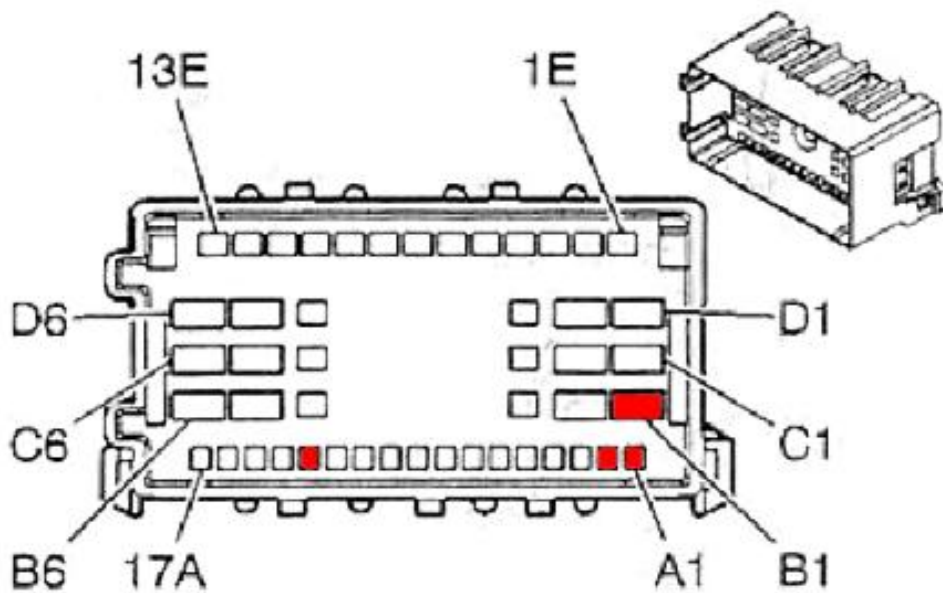

BD Engine Brake Inc.

Plant Address: 33541 MacLure Rd. Abbotsford, BC, Canada V2S 7W2

U.S. Shipping Address: 88-446 Harrison St, Sumas, WA 98295 U.S. Mailing Address: P.O. Box 231, Sumas, WA 98295

Phone: 604-853-6096 | Fax: 604-853-8749 | Internet: [www.bd-power.com](http://www.bd-power.com)



### 2003-2007 Duramax Trucks

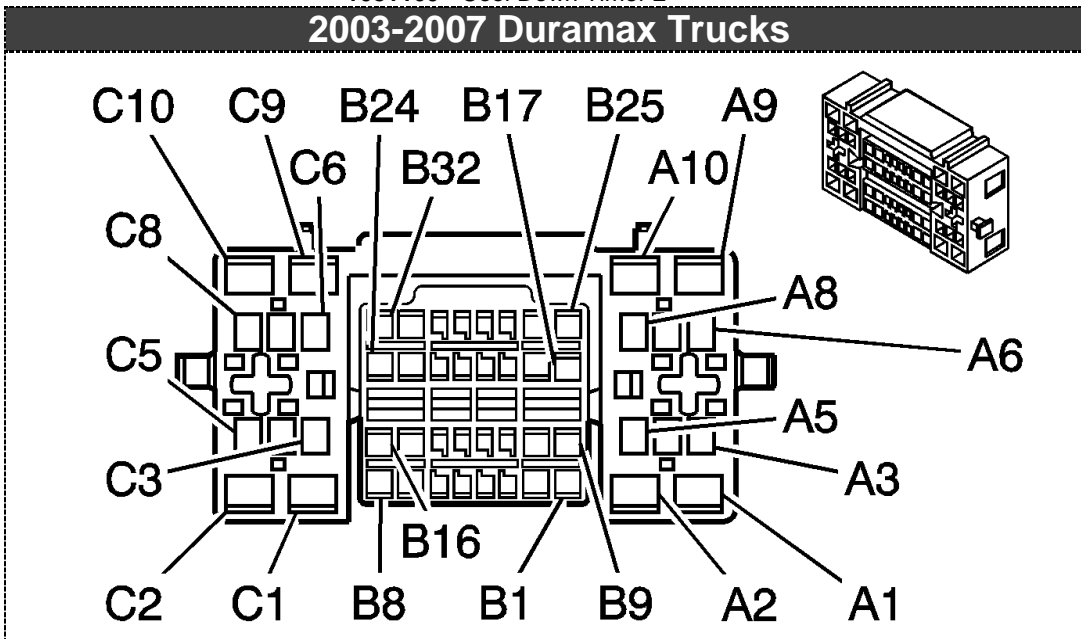

### 2007.5-9 Duramax Trucks

Below the I/P

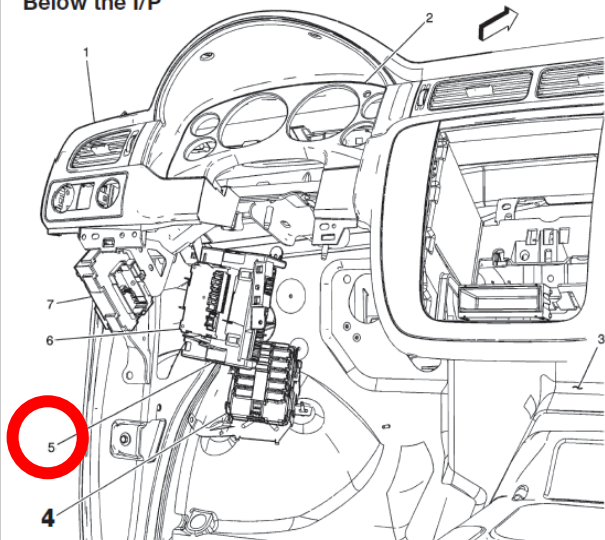

- (1) I/P Trim
- (2) I/P Cluster Trim
- (3) Floor Panel
- (4) Junction Block - Left I/P**
- (5) Body Control Module (BCM)
- (6) Transfer Case Shift Control Module
- (7) Fuse Block - I/P

1888353

Locate the BCM (#5).

Connector X1, Light Green in color. Face shown is internal matting face. You will need to access the reverse of this.

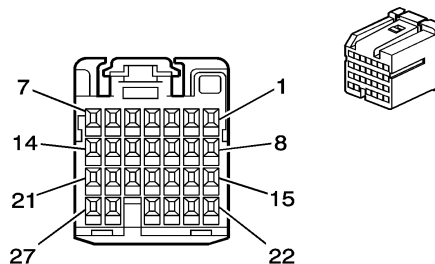

Connector X2, White in color. Face shown is internal matting face. You will need to access the reverse of this.

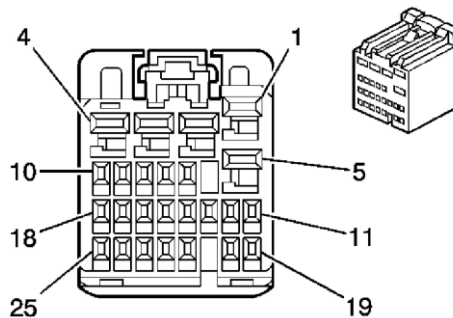

BD Engine Brake Inc.

Plant Address: 33541 MacLure Rd. Abbotsford, BC, Canada V2S 7W2

U.S. Shipping Address: 88-446 Harrison St, Sumas, WA 98295 U.S. Mailing Address: P.O. Box 231, Sumas, WA 98295

Phone: 604-853-6096 | Fax: 604-853-8749 | Internet: www.bd-power.com

<b>Model</b>	<b>Location</b>	<b>OEM Wire</b>	<b>Pin</b>
<b>Brake Pedal (Blue Wire)</b>			
<b>2001-2002</b>	Ignition Connector C201	<b>WT 17</b>	A1
<b>2003-2007</b>	Brake Pedal Connector	<b>WT 5689</b>	2
<b>2007.5-2009</b>	Brake Pedal Connector	<b>Light Blue/White</b>	B
<b>Key (Green Wire)</b>			
<b>2001-2002</b>	Ignition Connector C201	<b>BR 41</b>	A13
<b>2003-2007</b>		<b>BR 41</b>	B18
<b>2007.5-2009</b>	Body Control Module (BCM) X1	<b>PK 1020</b>	2
<b>Keep Alive (Tan Wire)</b>			
<b>2001-2007</b>	Ignition Connector C201	<b>PK 139</b>	A2
<b>2007.5-2009</b>	Body Control Module (BCM) X1	<b>PK 3</b>	14
<b>Constant (Pink Wire)</b>			
<b>2001-2002</b>	Ignition Connector C201	<b>RD 242</b>	B1
<b>2003-2007</b>		<b>RD 342</b>	C1
<b>2007.5-2009</b>	Body Control Module (BCM) X2	<b>Red/White</b>	2

BD Engine Brake Inc.

Plant Address: 33541 MacLure Rd. Abbotsford, BC, Canada V2S 7W2

U.S. Shipping Address: 88-446 Harrison St, Sumas, WA 98295 U.S. Mailing Address: P.O. Box 231, Sumas, WA 98295

Phone: 604-853-6096 | Fax: 604-853-8749 | Internet: [www.bd-power.com](http://www.bd-power.com)

## ***Thermocouple Wiring (Not needed if monitoring with Time vs. Temp)***

On most common “K” type thermocouples and wiring, a **yellow** wire is connected to the positive (+) side and a **red** wire is connected to the negative (-) side. The following are three common ways to connect the thermocouple to the CDT2 module. In all cases, the positive side of the thermocouple will be connected to the “Thermocouple +” terminal as indicated on the CDT2 module drawings and the negative side will be connected to the “Thermocouple -” terminal.

### **Direct Thermocouple Connection**

If there is no pyrometer gauge in the vehicle and a thermocouple is being installed to connect to the CDT2 module, follow this diagram:

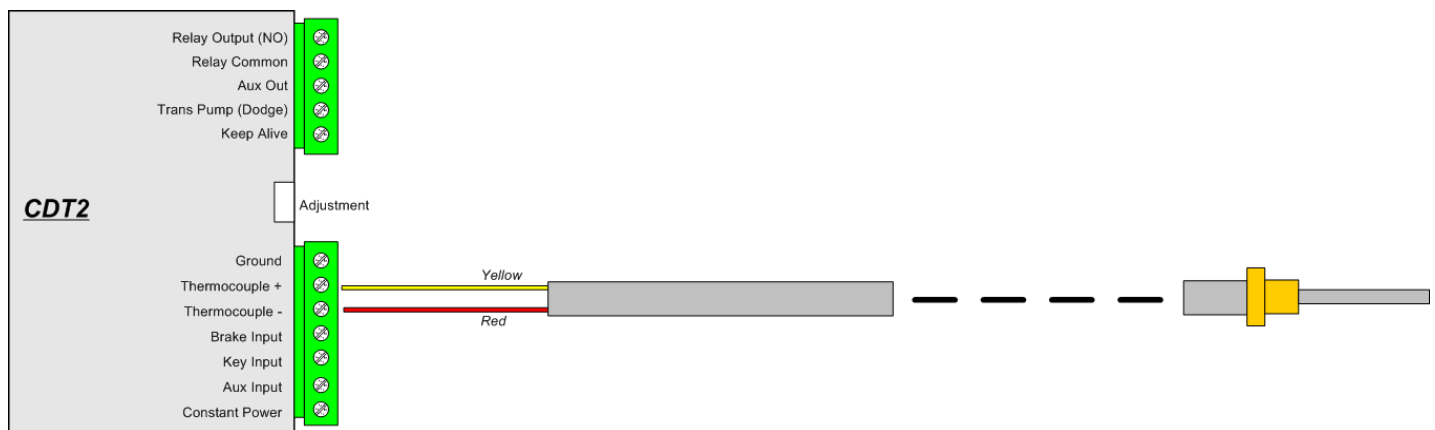

### **Amplified Pyrometer Gauge Kit**

Some pyrometer gauge kits utilize a powered amplifier in between the pyrometer gauge head and the thermocouple. If the vehicle has one of these systems installed, use the following diagram:

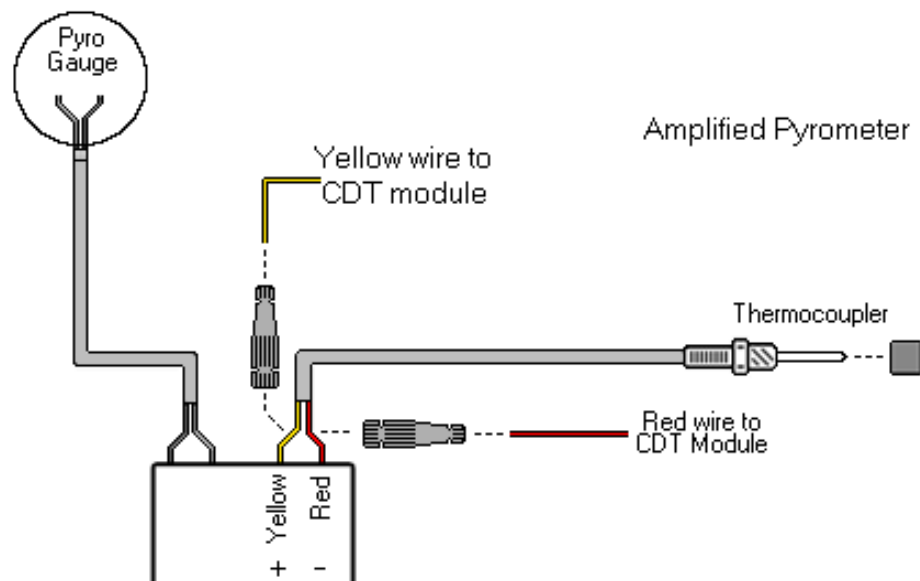

BD Engine Brake Inc.

Plant Address: 33541 MacLure Rd. Abbotsford, BC, Canada V2S 7W2

U.S. Shipping Address: 88-446 Harrison St, Sumas, WA 98295 U.S. Mailing Address: P.O. Box 231, Sumas, WA 98295

Phone: 604-853-6096 | Fax: 604-853-8749 | Internet: [www.bd-power.com](http://www.bd-power.com)

## **Conventional Non-Amplified Pyrometer Kit**

A conventional pyrometer gauge kit will have the thermocouple connected to the pyrometer gauge head via a lead wire. If the vehicle has one of these systems installed, use the following diagram:

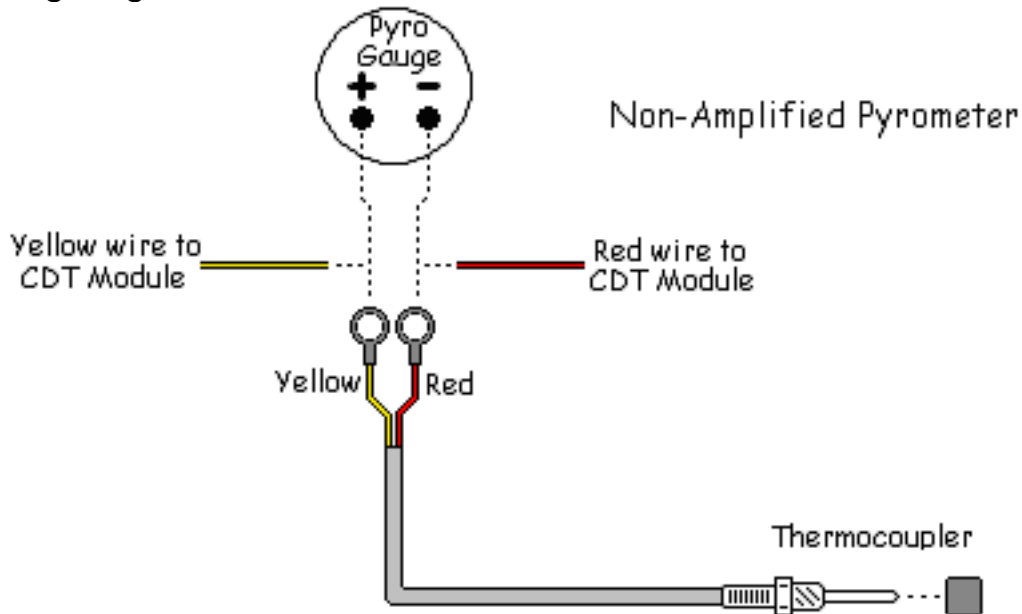

## ***Temperature Adjustment***

The shutdown temperature can be set by using a small flat-headed screwdriver to adjust the potentiometer that can be accessed through the hole on the left side of the CDT2 module.

By turning the screw all the way to the right (clockwise), the CDT2 will shutdown at approximately 550°F. By turning the potentiometer all the way counter-clockwise, the CDT2 will shutdown at approximately 250°F. The CDT2 may have to be adjusted a few times until the desired shutdown temperature is achieved.

**NOTE:** Be careful not to apply too much pressure as the potentiometer is plastic and can break.

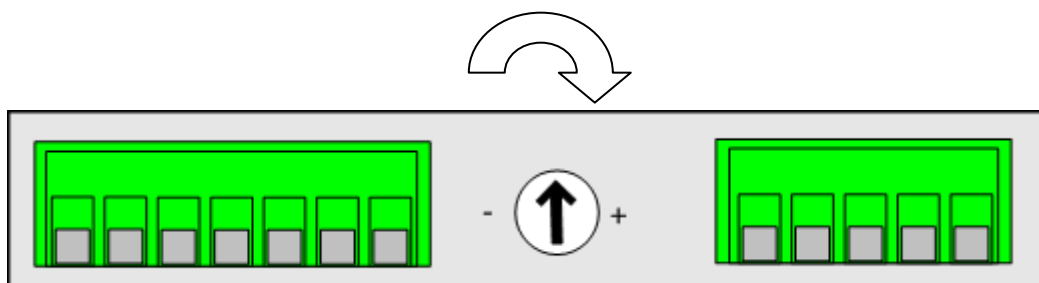

**Adjustment Range: 250° to 550°**

BD Engine Brake Inc.

Plant Address: 33541 MacLure Rd. Abbotsford, BC, Canada V2S 7W2

U.S. Shipping Address: 88-446 Harrison St, Sumas, WA 98295 U.S. Mailing Address: P.O. Box 231, Sumas, WA 98295

Phone: 604-853-6096 | Fax: 604-853-8749 | Internet: [www.bd-power.com](http://www.bd-power.com)

# Time Adjustment

By default the CDT2 is setup to use the temperature as the default shutoff source. The unit can now be configured to use an adjustable time. If you unscrew the unit separating the two enclosure halves (the screw is located under the CDT2 sticker, in the middle of the module), you will see a jumper. You will need to set the jumper so that it connects pins 1 & 2. See the diagram below for more information.

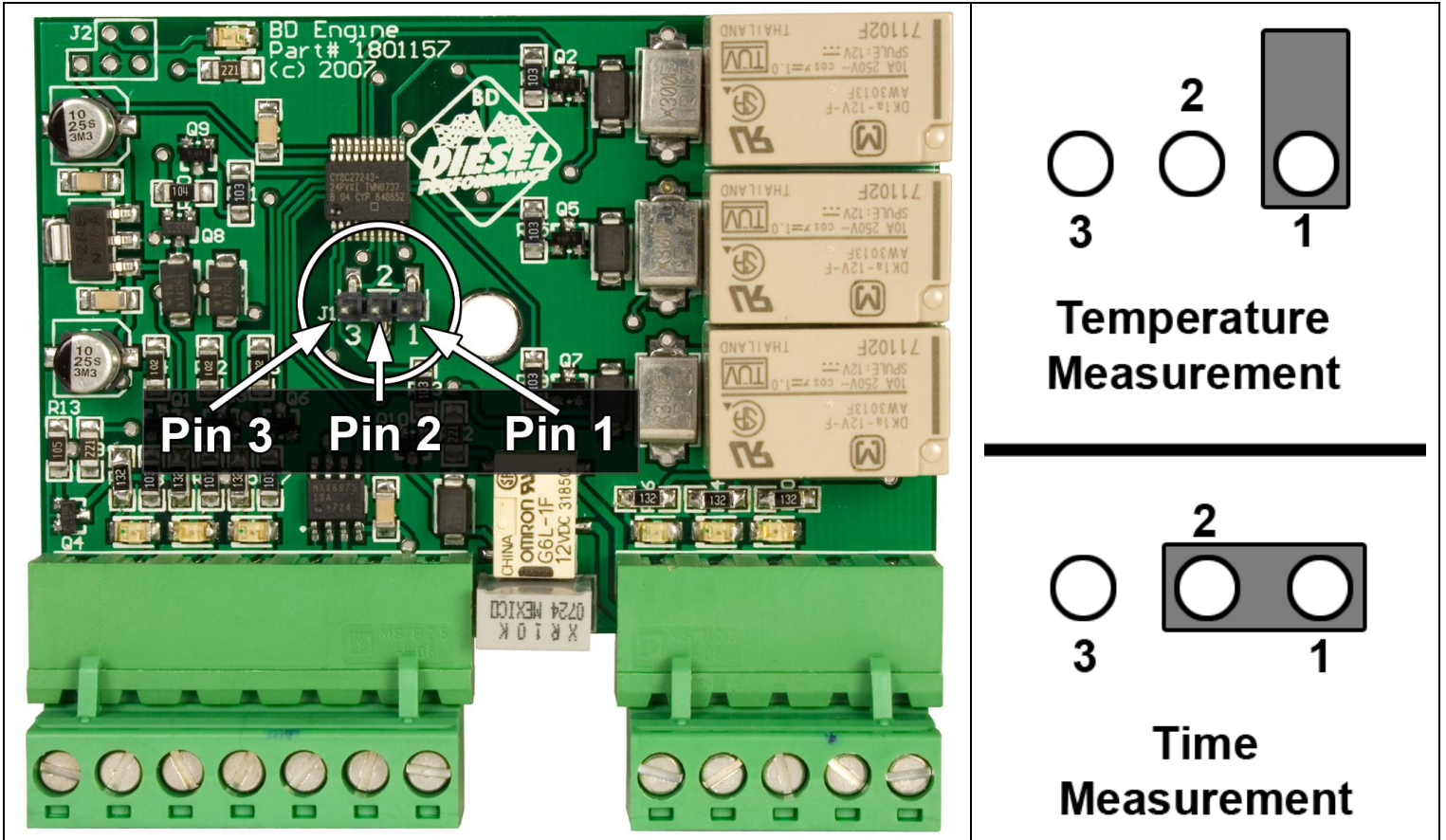

To adjust the time you can turn the potentiometer on the side of the unit.

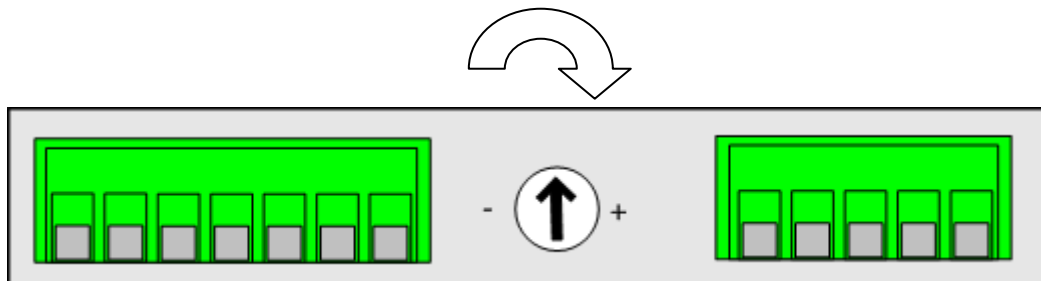

**Adjustment Range: 60 to 300 seconds**

## **Communication / Operation Lights**

There are a number of new feature that will help troubleshoot problems and indicate correct operation. These LED correspond and are aligned with their corresponding input outputs.

<b>Inputs</b>	<b>LED Operation</b>
<i>Key</i>	Lit when supplied power
<i>Aux. In</i>	Lit when supplied power
<i>Brake Input</i>	Lit when Brake is depressed
<i>Temperature</i>	Lit when temperature is above set point
<b>Outputs</b>	<b>LED Operation</b>
<i>Aux Out</i>	Lit when output powered
<i>Transfer Pump</i>	Lit when output powered
<i>Keep Alive</i>	Lit when output powered

## **Mounting**

Once all the wiring and adjustments have been performed, secure or mount the CDT2 module so that it is not interfering with feet and/or moving parts or near direct heat. We suggest using Velcro to mount to the firewall or zap-strapping to a suitable place such as the back of the X-Monitor module. Being that the CDT2 module is light, it can be suspended if the wiring is secure.

## **Technical Assistance**

If you required technical assistance with the installation or operation of this kit, please contact us at **604-853-6096**, Monday to Friday, 8:00am to 5:00 Pacific Time. We can also be contacted via email at [techline@bd-power.com](mailto:techline@bd-power.com) or visit our discussion forum site at <http://forum.bd-power.com/>.



BD Engine Brake Inc.

Plant Address: 33541 MacLure Rd. Abbotsford, BC, Canada V2S 7W2

U.S. Shipping Address: 88-446 Harrison St, Sumas, WA 98295 U.S. Mailing Address: P.O. Box 231, Sumas, WA 98295

Phone: 604-853-6096 | Fax: 604-853-8749 | Internet: [www.bd-power.com](http://www.bd-power.com)

## Wire Color Glossary

<b>BK</b>	Black	<p>In the wiring diagrams, there are usually two wire colors for each OEM wire, for example: RD/LB. This means it's a red colored wire with a light blue tracer.</p>
<b>BR</b>	Brown	
<b>DB</b>	Dark Blue	
<b>GN</b>	Green	
<b>GY</b>	Gray	
<b>LB</b>	Light Blue	
<b>LG</b>	Light Green	
<b>OR</b>	Orange	
<b>PK</b>	Pink	
<b>RD</b>	Red	
<b>TN</b>	Tan/Light Brown	
<b>WT</b>	White	
<b>YL</b>	Yellow	

BD Engine Brake Inc.

Plant Address: 33541 MacLure Rd. Abbotsford, BC, Canada V2S 7W2

U.S. Shipping Address: 88-446 Harrison St, Sumas, WA 98295 U.S. Mailing Address: P.O. Box 231, Sumas, WA 98295

Phone: 604-853-6096 | Fax: 604-853-8749 | Internet: [www.bd-power.com](http://www.bd-power.com)

# Troubleshooting

## COMPLAINT: VEHICLE WON'T STAY RUNNING

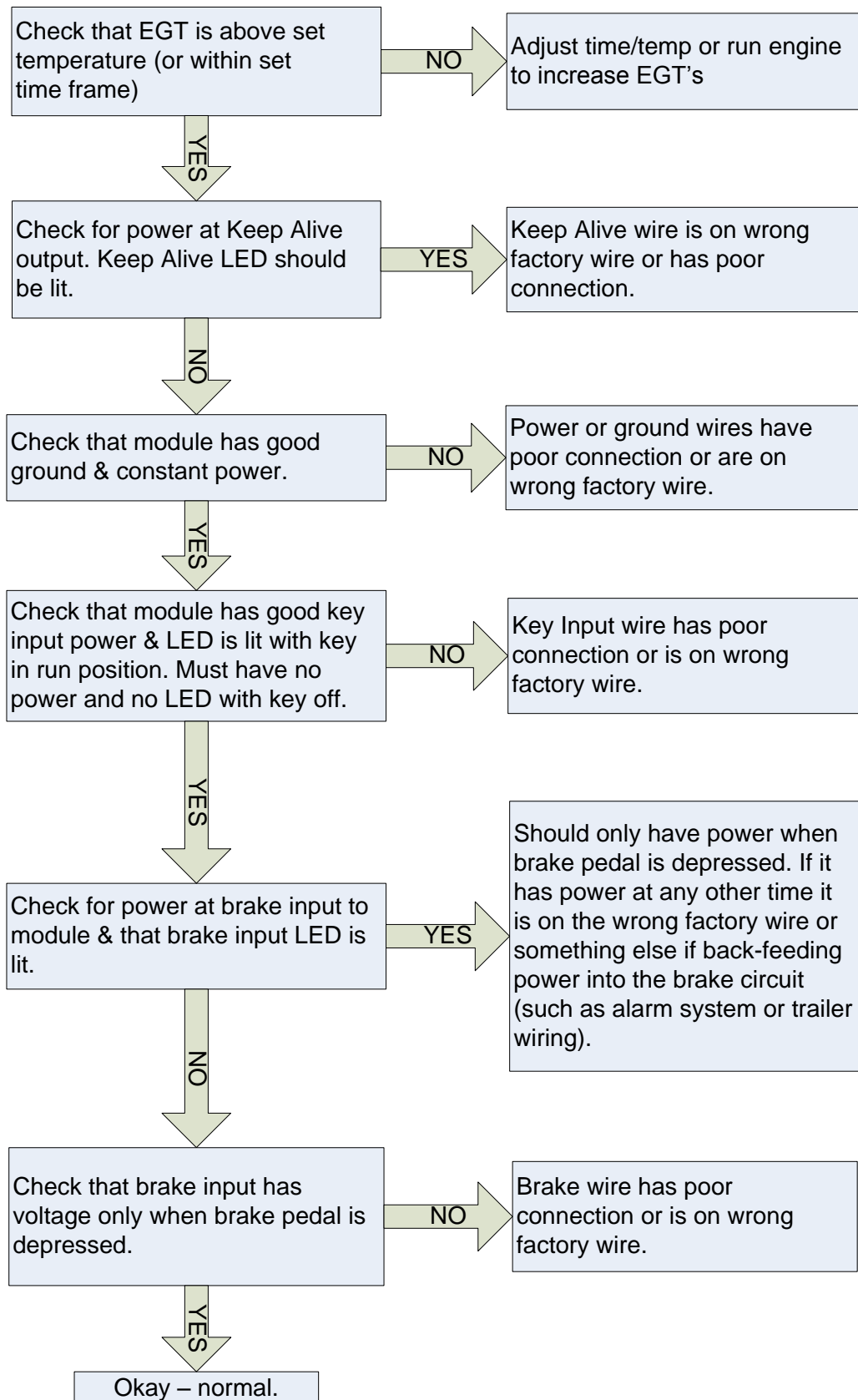

BD Engine Brake Inc.

Plant Address: 33541 MacLure Rd. Abbotsford, BC, Canada V2S 7W2

U.S. Shipping Address: 88-446 Harrison St, Sumas, WA 98295 U.S. Mailing Address: P.O. Box 231, Sumas, WA 98295

Phone: 604-853-6096 | Fax: 604-853-8749 | Internet: [www.bd-power.com](http://www.bd-power.com)