



BD Ford 2003-2007 6.0L Powerstroke ***CRANKCASE VENTILATION KIT***

P/N# 1032175



PLEASE READ ALL INSTRUCTIONS BEFORE INSTALLATION

KIT CONTENTS:

Please check to make sure that you have all the parts listed in this kit before you start the disassembly of your truck.

1302170		1302180	
			
<i>CCV Canister Unit</i>		<i>6L CCV Bracket</i>	
Qty: 1		Qty: 1	
1302190	1302191	1302185	1302172
			
<i>Outlet 90° Hose</i>	<i>Inlet Straight Hose</i>	<i>Reservoir bracket</i>	<i>CCV Catch Can</i>
Qty: 1	Qty: 1	Qty: 1	Qty: 1
1400104	1604054	1110033	1110031
			
<i>Barbed Fitting 1/2" hose – 1/4" NPT</i>	<i>1/2" Hose</i>	<i>5/16" Nut</i>	<i>5/16" Washer</i>
Qty: 1	Qty: 23"	Qty: 2	Qty: 4

1302195	1302197	1100111	1604124
			
<i>Drain Spring Clamp #19</i>	<i>Piping Spring clamp #32</i>	<i>1/4" Flat Washer</i>	<i>1/4 x5/8 NC Bolt</i>
Qty: 2	Qty: 4	Qty: 2	Qty: 2
1120031	1604104	1110032	1100112
			
<i>3/8" Lock Washer</i>	<i>5/16"x 1 NC Bolt</i>	<i>5/16" Lock Washer</i>	<i>1/4" Lock Washer</i>
Qty: 1	Qty: 2	Qty: 2	Qty: 2

1120030	1200105	1120033
		
<i>Bolt – 3/8" x 1 1/4"</i>	<i>3/8" Washer</i>	<i>3/8" Nut</i>
Qty: 1	Qty: 2	Qty: 1

Welcome

Thank you for purchasing the Ford 6.0L Power Stroke CCV kit. This manual is divided into different areas to assist you with the installation and maintenance of your CCV system.

This product is designed specifically for the 6.0L Power Stroke to aid in reducing the amount of oil found in the Charge Air Cooler, and the chance of having a boot blow off. The system will help to increase boot life and charge air cooler effectiveness. Better filtration of the crankcase gas reduces the amount of oil that will be returned to the intake system, which in turn will reduce emissions.

Installation should occur on a vehicle properly secured to prevent rolling. Draining of the oil retention canister at regular oil change intervals will help to optimize the oil removal ability of the system.

Required Tools

- 1/4" wrench
- 7/16" wrench
- 1/2" wrench
- 9/16" wrench
- #2 Phillips screw driver bit.
- 3/4"-7/8" Drill bit

Maintenance

- Drain oil retention canister at regular oil change intervals.
- Change filter (#1302171) every 30,000 miles or 1 year.



To change the filter unscrew the cap off of the canister, grasp the handle on the filter & pull it out of the canister. It should come out with a firm tug.

BD Engine Brake Inc.

Plant Address: 33541 MacLure Rd. Abbotsford, BC, Canada V2S 7W2

U.S. Shipping Address: 88-446 Harrison St, Sumas, WA 98295 U.S. Mailing Address: P.O. Box 231, Sumas, WA 98295

Phone: 604-853-6096 | Fax: 604-853-8749 | Internet: www.bd-power.com

INSTALLATION



1. Remove the turbocharger air intake plastic pipe, and the air filter box from the vehicle.

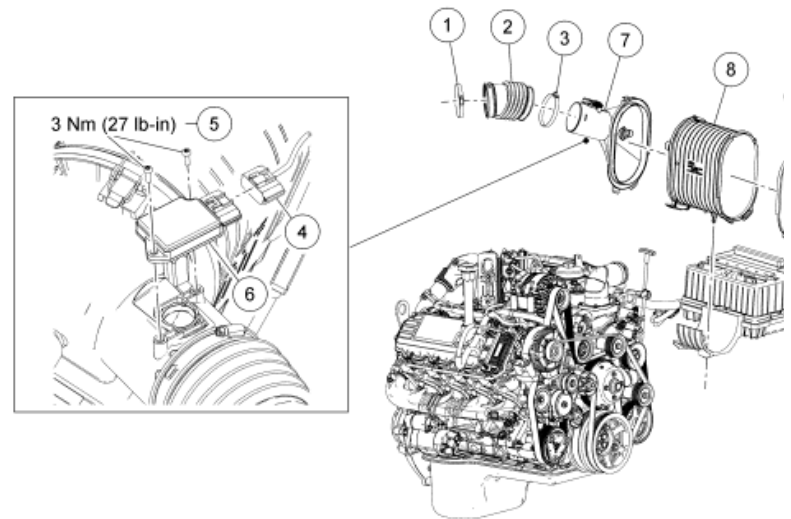

2. Remove the turbo air inlet hose and snorkel.

Disconnect the breather hose from the valve cover.

Remove the breather hose from the air inlet tube.

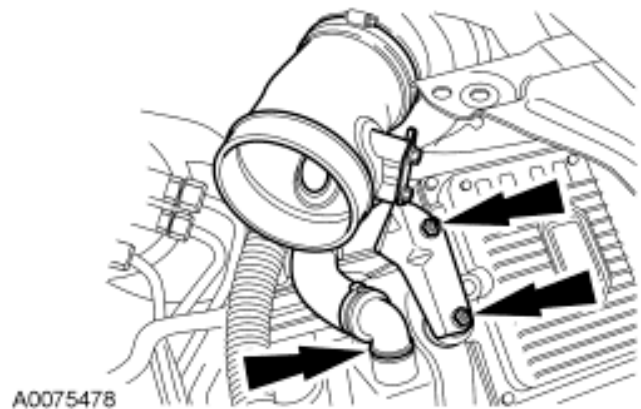

3. Connect Inlet Hose (straight end hose #**1302191**) to valve cover breather port. Secure this connection with a #32 spring clamp (#**1302197**).

Connect Outlet hose (90° end hose #**1302190**) to turbo air inlet pipe. Secure this connection with #32 spring clamp.

Route new breather hoses over the radiator shroud. Below upper radiator hose and intercooler tube, towards the passenger side battery.

Keep the hose away from any moving or hot parts.



4. Re-install the turbo inlet tube, with hose attached. Be sure no kinks are formed.

5. Remove passenger side 10mm radiator mounting bolts and two 13mm bolts from radiator support.

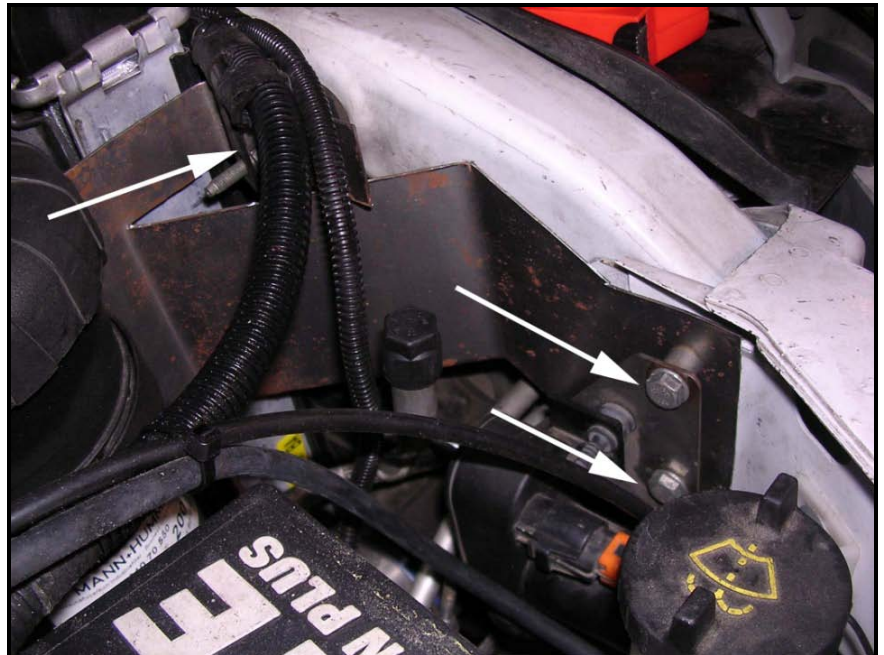

6. Install CCV canister into the bracket (#1302180) using the provided 5/16" hardware. You may have to undo the latch on the plastic canister holder & clock the canister to match what is shown in the illustration. Then install the canister & bracket assembly into the vehicle using the bolts for the radiator support.

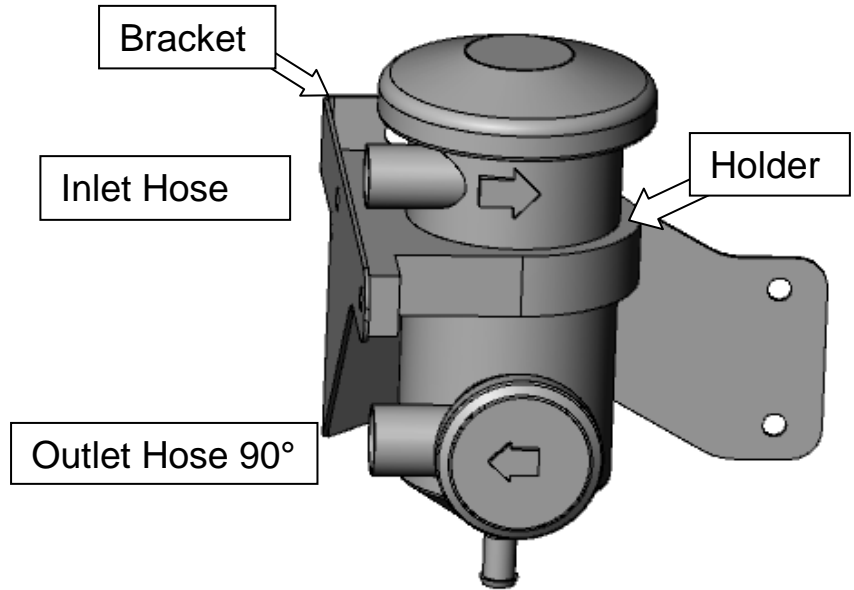

7. Install the Outlet Hose (bent hose ends 90°) to the bottom (Outlet) of the CCV Bottle with a #32 spring clamp.

Install the hose (Straight Hose) to the top (inlet) of the CCV Bottle with a spring clamp.

8. Re-install Intake Hose and Air Box.

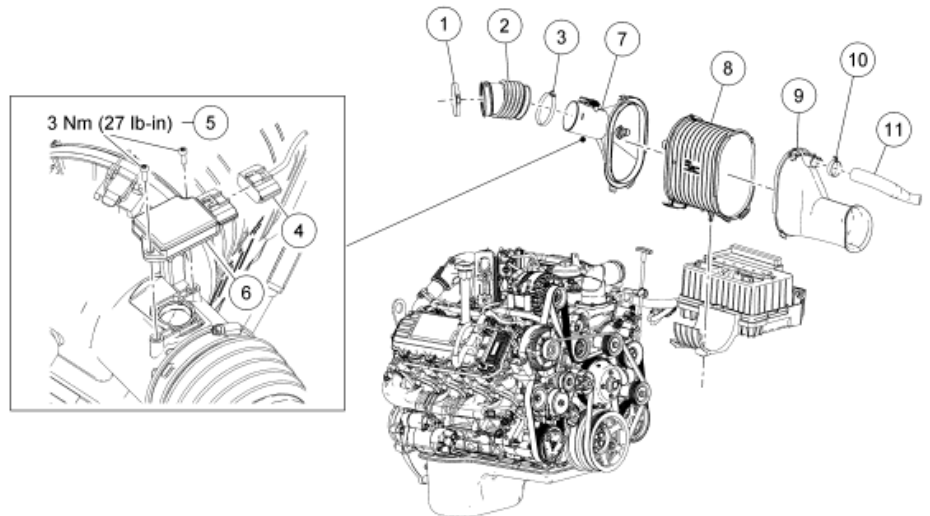

9. Install barbed fitting into the top of the catch bottle. The fitting will thread itself into the bottle. You will have to use a 9/16" wrench for this. You should bottom the fitting into bottle.



10. Attach the CCV reservoir (#1302172) to mounting bracket (#1302185).

Hold catch can assembly where it will be mounted on the frame. There should be a 3/8" to 1/2" mounting hole.

Mark inner fender for the location of 1/2" drain hose access hole. You will need to drill this hole in the plastic using a 3/4" to 7/8" drill bit.



11.

CAUTION

Watch for hoses and wires, when drilling the access hole.

Using the 3/8" hardware provided you can secure the catch can assembly to the frame.



12. Install the drain hose from the bottom of CCV Bottle through the hole in the fender liner.

Secure both the CCV filter connection and the catch can with #19 spring clamps.

Your installation is now complete.



To drain the oil catch can, turn the lever to the open position.

This catch can should be drained every oil change.

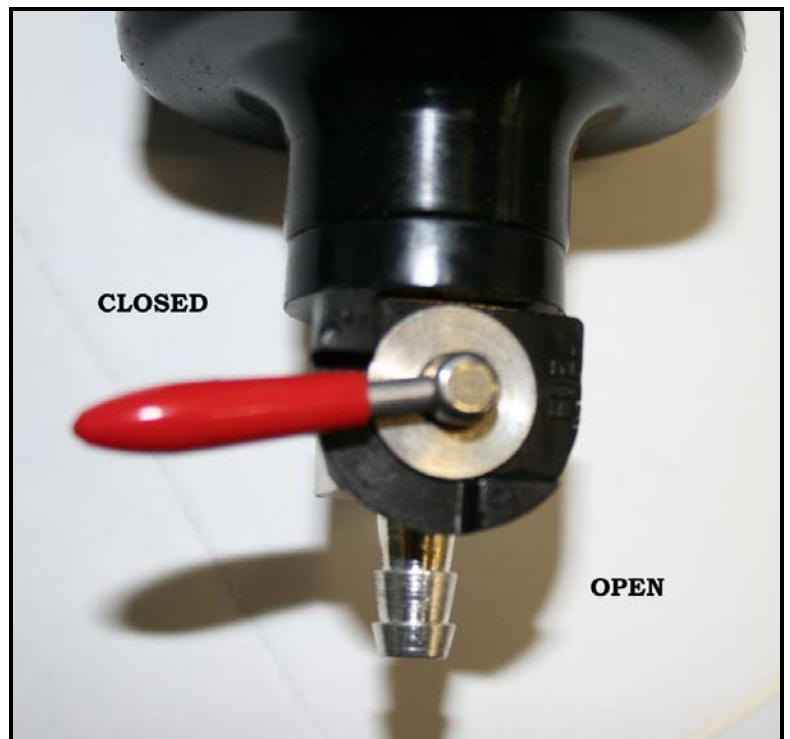

IF THERE ARE ANY KINKS IN THE HOSES OR THE FILTER BECOMES PLUGGED, YOU MAY DEVELOP THE FOLLOWING SYMPTOMS:

BLOWN OIL GASKETS, INCREASED CONSUMPTION OF OIL OR TURBOCHARGER OIL LEAKS.

BD Engine Brake Inc.

Plant Address: 33541 MacLure Rd. Abbotsford, BC, Canada V2S 7W2

U.S. Shipping Address: 88-446 Harrison St, Sumas, WA 98295 U.S. Mailing Address: P.O. Box 231, Sumas, WA 98295

Phone: 604-853-6096 | Fax: 604-853-8749 | Internet: www.bd-power.com

Troubleshooting

If you have any technical difficulties, concerns, comments, or complaints, please phone our Technical Support hotline at (800) 887-5030 between 8:30am-5:00pm PST (Pacific Standard Time) Monday to Friday, or post a message on the BD Discussion Forums located at:

<http://forum.bd-power.com/>



Visit our Internet forums at <http://www.dieselpower.com> and share your comments or technical support questions with some of the industry's leading experts in the diesel field.

BD Engine Brake Inc.

Plant Address: 33541 MacLure Rd. Abbotsford, BC, Canada V2S 7W2

U.S. Shipping Address: 88-446 Harrison St, Sumas, WA 98295 U.S. Mailing Address: P.O. Box 231, Sumas, WA 98295

Phone: 604-853-6096 | Fax: 604-853-8749 | Internet: www.bd-power.com