

FAL460/FS9460

2015-2016 FORD 6.7L
POWERSTROKE F250/F350/F450 PICK UP

MBRP®

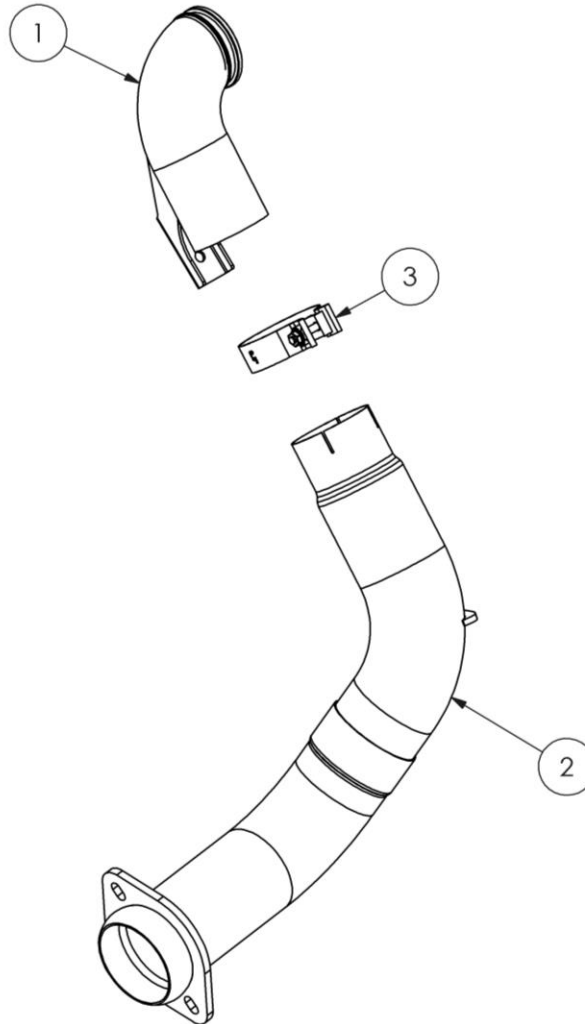

ITEM	DESCRIPTION	QTY
1	UPPER PIPE	1
2	LOWER PIPE	1
3	3.5" BAND CLAMP	1

PLEASE READ BEFORE STARTING INSTALLATION

While MBRP has made every effort to ensure that all components of this system are of superior quality and properly packaged, it is the installer's responsibility to ensure the following before removal of the factory exhaust:

- that ALL components shown above are present.
- that ALL mating components fit together.
- that there are no damaged components.
- that the system you have purchased is appropriate for your vehicle year, model and configuration.
- that the system will not interfere with any modifications previously installed or planned.
- that you have read and understand these instructions.

If you have any questions or are uncertain about any aspect of the installation of this system to your vehicle please contact your dealer before commencing installation.

MBRP®

Removal of Stock Down Pipe



Figure 1

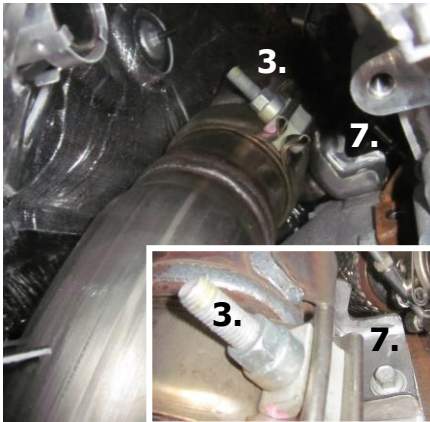

Figure 2



Figure 3



Figure 4



Figure 5

1. Remove the front passenger-side wheel and then remove the wheel liner to access the upper half of the stock down pipe. Retain all fasteners.

2. Remove the 2 OEM bolts from the ball flange at the outlet of the down pipe. **Refer to Figure 1.**

3. Loosen the clamp connecting the upper and lower halves of the stock down pipe. **Refer to Figure 2.**

4. Remove the nut securing the support tab to the engine. Retain the nut, as it will be reused.

5. Use a pry-bar to shift the particulate filter rearward to allow the bottom end of the OEM down pipe to drop down and be removed.

6. Loosen the OEM V-band Clamp at the turbo outlet. Once loose, the clamp t-bolt can be released from the clamp.

7. Remove the bolt securing the bracket at the bottom end of the upper down pipe section. Do not discard the bolt. **Refer to Figure 2.**

8. The upper half of the down pipe can now be removed. If it is stuck in place, it may be necessary to use a pry bar and/or an air hammer to loosen it.

Installation of MBRP Down Pipe:

1. To install the **Upper Pipe** onto the turbo, it is helpful to first over-expand the stock v-band clamp and place it over the turbo outlet flange, orientating it such that the nut and bolt will be accessible.

2. Place the **Upper Pipe** into position such that the support bracket hole is aligned with the bolt hole on the engine, then loosely thread the stock flange bolt into place. (May require a 2nd person from underneath the truck). **Refer to Figure 3.**

3. Rotate the **Upper Pipe** into place against the turbo outlet, move the V-band clamp onto the flange, then tighten the support bracket flange bolt to secure the pipe

MBRP®

4. Re-latch the T-bolt on the V-band clamp, then begin to tighten the clamp. Before the clamp is fully tightened, loosen the flange bolt on the support bracket to allow the **Upper Pipe** flange to seat properly against the turbo flange. Tighten the v-band some more, but before it is completely tight, retighten the flange bolt so that the support bracket is fully secured against its mounting surface. Now, fully tighten the v-band clamp. **Refer to Figure 4.**
5. Place the supplied **Band Clamp** over the **Lower Pipe** and then slide the **Lower Pipe** onto the **Upper Pipe** while making sure that the support tab hole goes over the mounting stud. Install the flange nut onto the mounting stud to secure the support tab and then tighten the **Band Clamp**. **Refer to Figure 5.**
6. Align the edge of each band clamp with the edge of the joint it is connecting. Tighten all hardware and clamps, starting at the front and working rearward to secure the system. Check along the full length of the exhaust system to ensure there is adequate clearance for fuel lines, vent lines, brake lines, frame, bodywork, suspension, and any wiring, etc. If there is any interference detected, relocate, or adjust to provide adequate clearance. Ensure all clamp connections are secure and components are unable to rotate or slide. Band clamps require approximately 45 lb-ft (60 N-m) of torque. Verify clearances, system security and band clamp torque after 30-60 miles (50-100 km) of driving. Secure the 2-bolt down pipe flange to the OEM exhaust flange using the OEM bolts previously removed. Replace the wheel liner and the front passenger-side wheel.
7. Secure the 2-bolt down pipe flange to the OEM exhaust flange using the OEM bolts previously removed. Replace the wheel liner and the front passenger-side wheel.

Congratulations! You are ready to begin experiencing the improved power, sound and driving excitement of your **MBRP** performance exhaust system. We know you will enjoy your purchase.