



with Installation Instructions

Owner's Manual

Low Temperature Pressure Sensor Remote Mount Kit

For use with all Banks Pressure Sensors

THIS MANUAL IS FOR USE WITH THE FOLLOWING PART NUMBERS:
66421 LOW TEMPERATURE PRESSURE SENSOR REMOTE MOUNT KIT

Gale Banks Engineering
546 Duggan Avenue • Azusa, CA 91702
(626) 969-9600 • Fax (626) 334-1743

Product Information & Sales: (888) 635-4565
Customer Support: (888) 839-5600
Installation Support: (888) 839-2700

bankspower.com

BANKS

General Installation Practices

Dear Customer,

If you have any questions concerning the installation of your air pressure sensor remote mount kit, please call our Technical Service Hotline at (888) 839-2700 between 7:00 am & 4:00 pm (PT). If you have any questions relating to shipping or billing, please contact our Customer Service Department at (888) 839-5600.

Thank you.

1. Before installing, familiarize yourself with the installation procedure by reading all of the instructions.
2. The exploded view (**Figure 1**) provides only general guidance. Refer to each step and figure in this manual for proper instruction.
3. Throughout this manual, the left side of the vehicle refers to the driver's side, and the right side to the passenger's side.
4. Disconnect the negative (ground) cable from the battery (or batteries, if there are two) before beginning work.
5. Route and tie wires and hoses a minimum of 6" away from exhaust heat, moving parts and sharp edges. Clearance of 8" or more is recommended where possible.
6. When raising the vehicle, support it on properly weight-rated safety stands, ramps or a commercial hoist. Follow the manufacturer's safety precautions. Take care to balance the

vehicle to prevent it from slipping or falling. When using ramps, be sure the front wheels are centered squarely on the topsides; put the transmission in park; set the hand brake or in gear if manual; and place chocks behind the rear wheels.

CAUTION! Do not use floor jacks to support the vehicle while working under it. Do not raise the vehicle onto concrete blocks, masonry or any other item not intended specifically for this use.

7. During installation, keep the work area clean. Do not allow anything to be dropped into intake, exhaust, or lubrication system components while performing the installation, as foreign objects will cause immediate engine damage upon start-up.

Tools Required:

- Phillips Screwdriver
- Hand drill or power drill
- 11/32" Drill Bit
- 3/32" Drill Bit (if using weld bung)
- 9/16" Drill Bit (if using premade bracket)
- 1/8"- 27 NPT Tap (optional)
- 7/16" wrench
- 11/16" wrench
- 15/16" or large adjustable wrench
- Thread Sealant
- Marker

Section 1: Included Parts

Figure 1 Banks Low Temperature Pressure Sensor Remote Mount Kit

Item #	Description	Part #	QTY
1	90° Push-Lock Swivel Fitting 1/8 NPT	45125	1
2	Nylon tubing, 6 Ft, Black	45140	1
3	BulkHead Fitting, 1/8 NPT to 1/4 Push-Lock	92145	1
4	Cable Clamp, Cushioned	62072	1

Figure 1

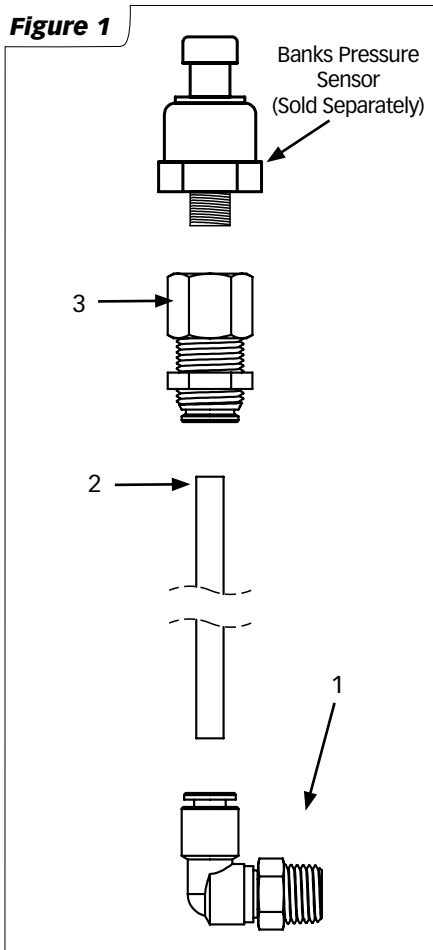

Introduction

This universal kit is used to obtain pressure readings from any engine component where temperatures do not exceed 220° F. Pressure sensors are most accurate at ambient temperatures. In order to achieve the most accurate measurements, it is recommended to remote mount the pressure sensor in front of the radiator. Sensors directly fitted to engine components may deteriorate quickly, therefore, a remote mount kit helps to isolate the temperature, ensure longevity, and improve accuracy of the sensor.

NOTE: For locations where the temperature will exceed 220° F, use Part Number: 66422 - LOW TEMPERATURE/EGT PRESSURE SENSOR REMOTE MOUNT KIT.

Installation

CAUTION! Drilling and tapping operations generate debris and can damage nearby components. In order to avoid damage to the vehicle, remove the component before drilling and tapping. Ensure that no debris enters the engine during the entire installation process.

1. Choose a location on your component to mount your 90° Push-Lock Swivel Fitting (*See Figure 1*). Recommended location is a section where the surface is flat and has minimal interference from other engine components. Be aware of any possible interference before the fitting is fully plumbed.

2. OPTION 1: Drill and Tap
(0.12" Minimum Wall-Thickness)

NOTE: It is **HIGHLY recommended that your component has a minimum 0.12" (~1/8") wall-thickness to drill & tap. Thinner walls will not provide the necessary engagement of at least 3 threads on the elbow fitting. Lower than 3 threads will not provide a secure fit.**

2a. Use a center punch to mark the hole's location and keep the drill bit from wandering. Use an 11/32" drill bit to drill a hole at marked location. Drill perpendicular to the surface to allow for accurate pressure readings. Deburr sharp edges and thoroughly clean out any leftover debris.

2b. Use a 1/8"-27 NPT tap to thread the drilled hole. Ensure the tap is perpendicular to the surface. As you tap, take care to prevent over-tapping by checking the thread depth once every rotation by removing the tap

and screwing in the elbow fitting. The fitting should screw in about 1-2 turns past hand tight (using a 7/16" wrench). This number can vary based on your chosen component's material. Be careful not to over tighten the fitting, especially when installing on soft materials like aluminum or plastic.

OPTION 2: Weld 1/8" Bung
(USE IF MATERIAL IS NOT THICK ENOUGH)
Part Numbers (sold separately):

92272- 1/8" steel weld bung

92281- 1/8 aluminum weld bung

2c. Use a center punch to mark the hole's location and keep the drill bit from wandering. Use a 3/32" bit and drill perpendicular to the surface to allow for accurate pressure readings. Deburr sharp edges and thoroughly clean out any leftover metal debris.

2d. Weld 1/8" bung aligned with previously drilled hole. Be sure to check for any weld protrusion on the inside of the component. Install the 90° elbow into welded bung.

3. Cut one side of the nylon tubing to obtain a clean edge.

NOTE: **When cutting the nylon tubing, use a fresh razorblade or tube cutter to obtain a clean edge. If a clean edge is not present, the tubing may not correctly lock into place within the fittings.**

4. Place previously cut end of nylon tubing into the swivel-end of the elbow fitting. You should feel a 'click' as the tubing locks into place.

5. Determine final location of sensor installation. The sensor should be mounted in a vertical or near-vertical position to ensure no moisture build-up occurs.

NOTE: To obtain accurate pressure readings, the sensor itself should be installed in a location where the closest to ambient temperature can be achieved. For this reason, it is recommended to install the sensor in front of the radiator. Mounting directly into the engine bay may lead to significant ambient temperature fluctuation.

6. Cut nylon tubing to desired length. Ensure final routing of tubing will not interfere with other components or place in an area where high temperatures will be reached.

NOTE: When cutting the nylon tubing, use a fresh razorblade or tube cutter to obtain a clean edge. If a clean edge is not present, the tubing may not correctly lock into place within the fittings.

Mounting

OPTION 1: Supplied P-Clamp

- 7a.** If using the supplied cushioned P-Clamp option, mark hole to be drilled. Ensure you have enough length to reach the location with your assembly, and that there is no interference with surrounding parts. Drill pilot hole for a small sheet metal screw, or a hole big enough to fit a 1/4" bolt (See Figure 2).
- 7b.** Using a small amount of thread sealant on the sensor's threads, install into the female portion of the BulkHead Fitting (using 15/16" and 11/16" wrenches). See Figure 1. Insert sensor into hose-clamp, and insert small sheet metal screw or 1/4" bolt into previously marked location to secure sensor. Remove small jam nut (See Figure 1) from the BulkHead Fitting (See Figure 2).



Fig 2: P-Clamp Mount Reference

OPTION 2: Bracket Mount

- 7c.** If using a pre-made bracket, drill a 9/16" hole to accommodate the BulkHead Fitting (See Figure 1). Use the small jam nut on the threaded portion of the BulkHead to secure the adapter to the bracket (See Figure 3).
- 7d.** Using a small amount of thread sealant on the sensor's threads, install into the female portion of the BulkHead Fitting (using 15/16" and 11/16" wrenches) (See Figure 3).
- 8.** Insert opposite end of nylon tubing into the push-lock side of the BulkHead Fitting (See Figure 1).
- 9.** Double check that both fittings are tight by lightly pulling on the nylon tubing near the push-lock portions.



Fig 3: Bracket Mount Reference

Gale Banks Engineering
546 Duggan Avenue • Azusa, CA 91702
(626) 969-9600 • Fax (626) 334-1743

Product Information & Sales: (888) 635-4565
Customer Support: (888) 839-5600
Installation Support: (888) 839-2700

bankspower.com