

INSTALLATION GUIDE



Power Step

MADE IN USA



APPLICATION

Ford Super Duty - Crew Cab 1999-2001 2004-2007

AMP Part

77104-01A

Note: The application works only on the Crew Cab model Vehicles.

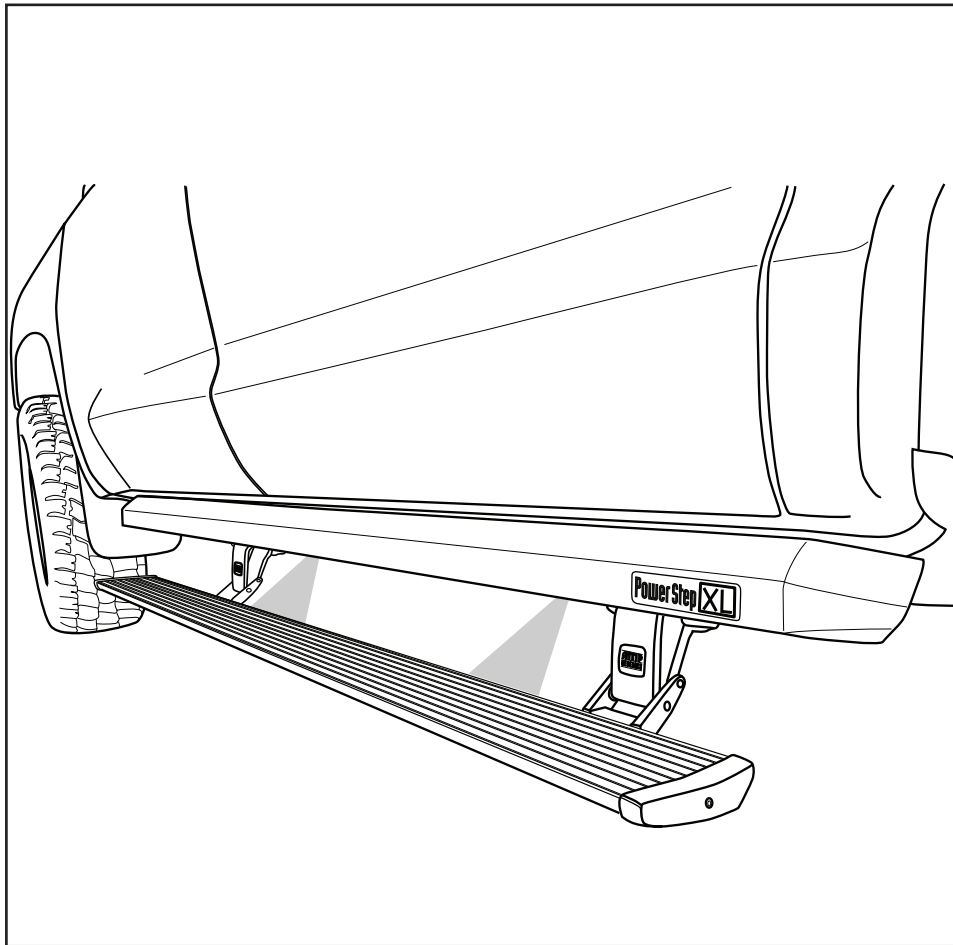

INSTALLATION TIME

3-5 Hours

Professional installation recommended

SKILL LEVEL



4= Experienced

TOOLS REQUIRED

- Safety goggles
- Measuring tape
- 10 mm socket
- 13 mm socket
- 1/2" socket
- Ratchet wrench and extension
- Wire crimpers
- Wire stripper / cutter
- 3/16" hex key wrench (allen wrench)
- 4mm hex key wrench (allen wrench)
- Electrical tape
- Weather proof caulking (silicone sealer)
- Silicone spray

WARRANTY

5-Year Limited Warranty

AMP RESEARCH TECH SUPPORT 1-888-983-2204 (Press 2) Monday - Friday, 7:00 AM - 5:00 PM PST

Invented, engineered and manufactured exclusively by AMP Research in the USA. May be covered by one OR MORE of the following patents: 6,641,158; 6,830,257; 6,834,875; 6,938,909; 7,055,839; 7,380,807; 7,413,204; 7,398,985; 7,584,975; 7,566,064; 7,487,986; 8,157,277; 8,408,571; 9,302,626; 9,561,751; 10,053,017; CA2463717 ©2012 AMP Research. All rights reserved. Printed in USA.

INSTALLATION GUIDE

Attaching motor to Linkage assembly.

EXPLODED VIEW

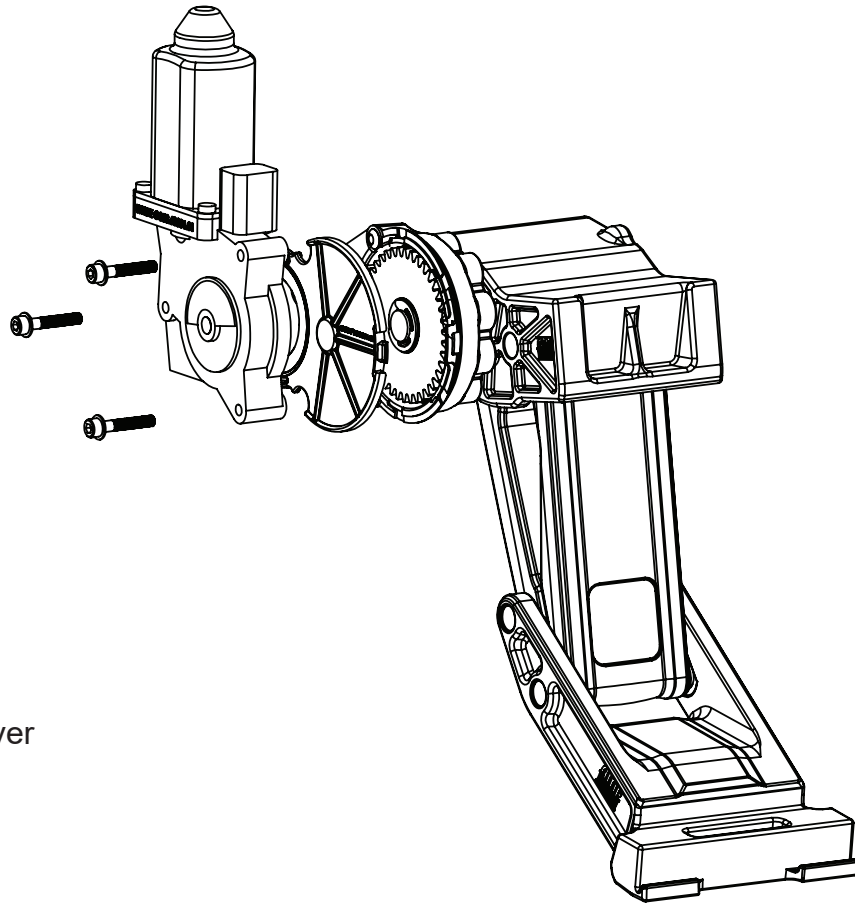

- Motor
- Socket cap screw
- Washer
- Drive Gear Housing Cover

CAUTION: HANDLE WITH CARE.

To ensure our customers receive all components with full integrity, we pack the motors separate from their linkage assemblies. This requires that the installer position and fasten the motor before continuing with the install. Please follow the instructions below and handle the assembly carefully.

CAUTION: Dropping the assembly or any excessive impact MAY cause damage to the motor.

Instructions:

1. Position the gear cover in place as shown if not already in place.
2. Seat motor into position on the three mounting bosses. This may require an adjustment of the gear by moving the swing arms.
3. After seating into place, fasten the motor with the three motor mount screws with 4mm Hex Head. Tighten screws to 36 in-lbs (4N-m). **Do not over torque.**

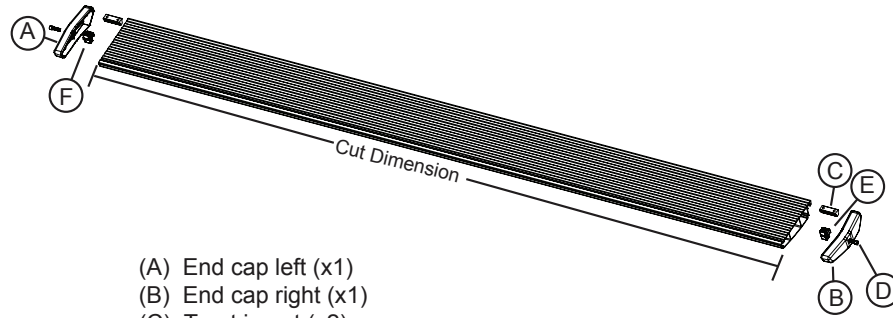

- (A) End cap left (x1)
- (B) End cap right (x1)
- (C) T-nut insert (x2)
- (D) Socket cap screw (x2)
- (E) End cap wedge right (x1)
- (F) End cap wedge left (x1)

1 x2

Running board assembly

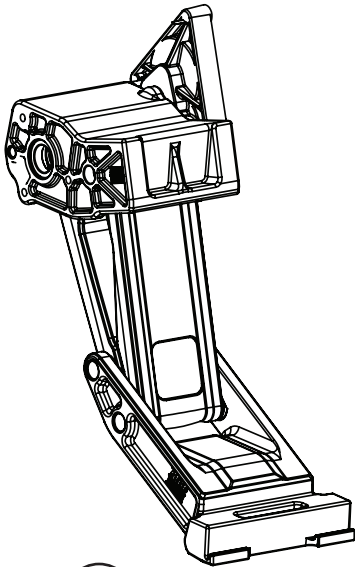

2 x2

Motor Linkage assembly

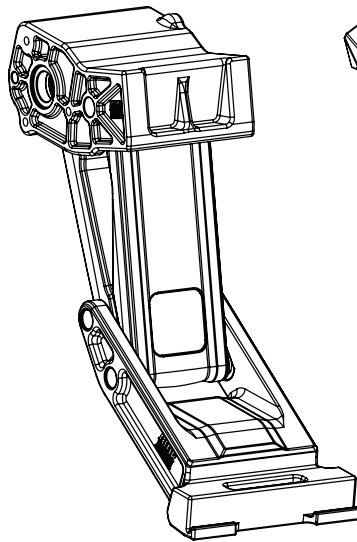

3 x2

Idler Linkage assembly

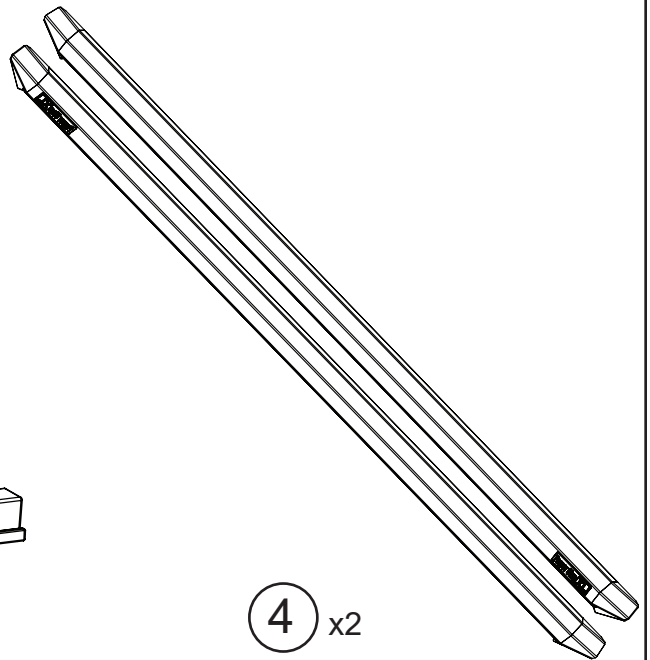

4 x2

Rail Assembly

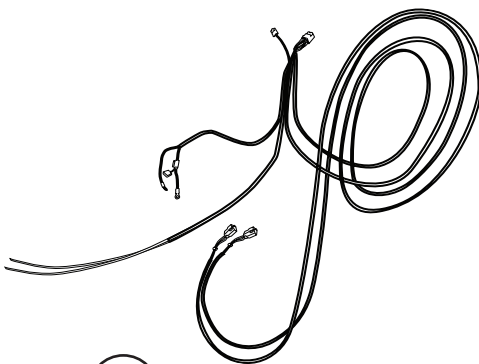

5

Wire harness

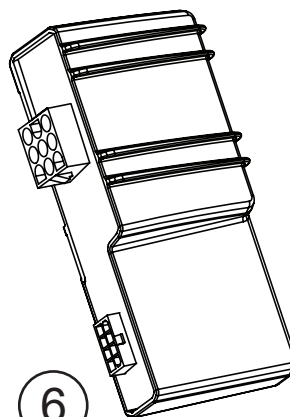

6

STA Controller

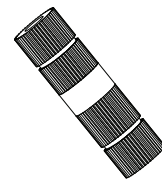

7 x4

Posi-Tap™

AMP RESEARCH POWERSTEP XL™ – FORD SuperDuty

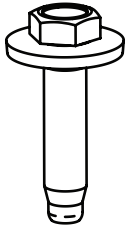

8 x18
M8 Hex Bolt w/
Conical washer

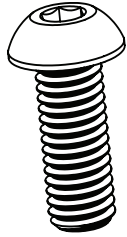

9 x10
M10 Button Head bolt

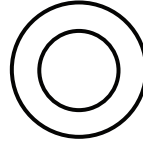

10 x10
M10 washer

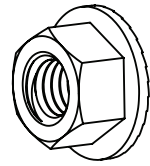

11 x10
Flange Nut

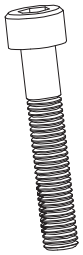

12 x6
M5 Hex Bolt



13 x6
M5 Washer

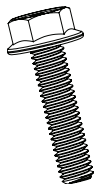

14 x4
M6 Flange Bolt

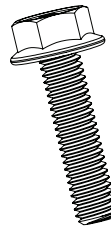

15 x6
5/16 Flange Bolt

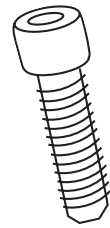

16 x8
Socket Cap Screw

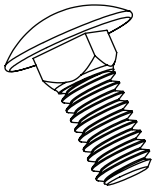

17 x14
5/16-18 Carriage Bolt

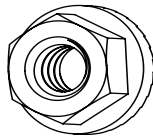

18 x20
5/16-18 Flange nut

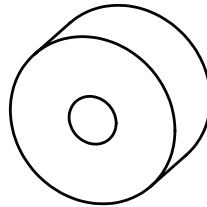

19 x4
Upper Mount Spacer

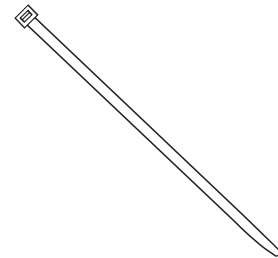

20 x20
Cable tie (7")



21 x10
M8 U-nut

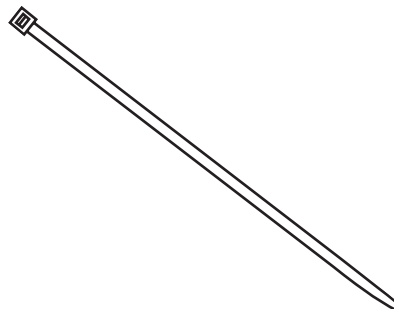

22 x2
Cable tie (11")

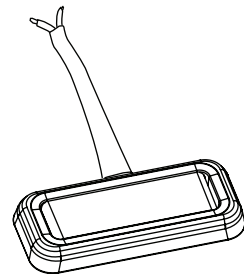

23 x4
LED Lamp

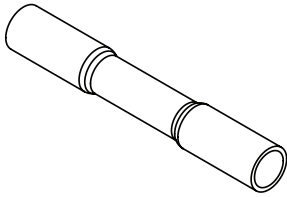

24 x10
Butt Connector

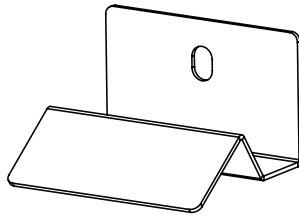

25 x4
LED Light Bracket

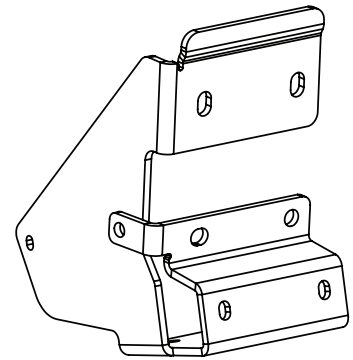

26 x4
Linkage Mounting Bracket

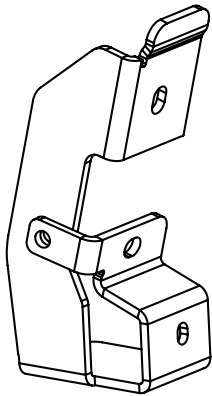

27 x2
Rail Mounting Bracket

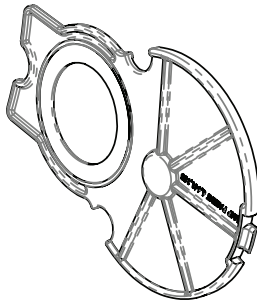

28 x2
Gear Cover

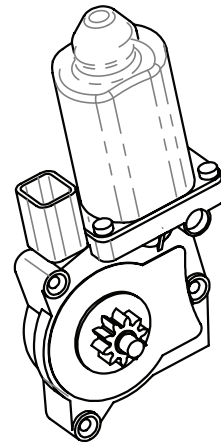

29 x2
Motor

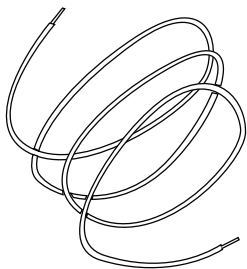

30 x2
Connecting wire (red)

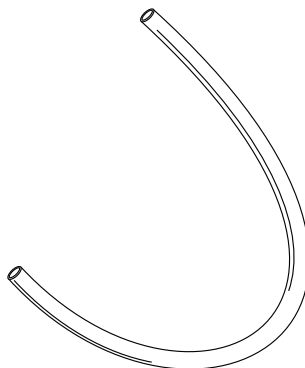

31
Tubing (installation tool)

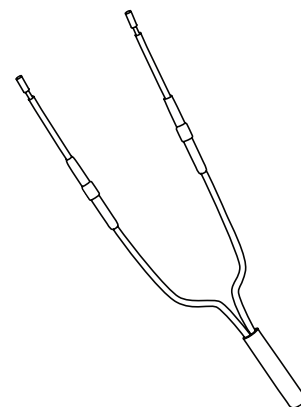

32 x2
Double-diode
(Not required for all applications
See Wiring Guides for details)

AMP RESEARCH POWERSTEP XL™ – FORD SuperDuty

Insert 7 Carriage bolts (17) into slot on rail (4). Insert from either end of rail. Add 2 Light Brackets (25) on the 3rd and 5th bolt. Insert Flange nut (18) onto bracket tab to attach light brackets into position shown.

Leave loose to allow for adjustment.

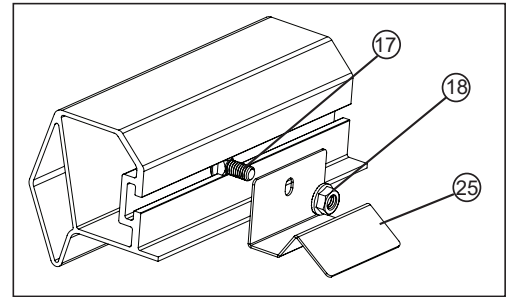
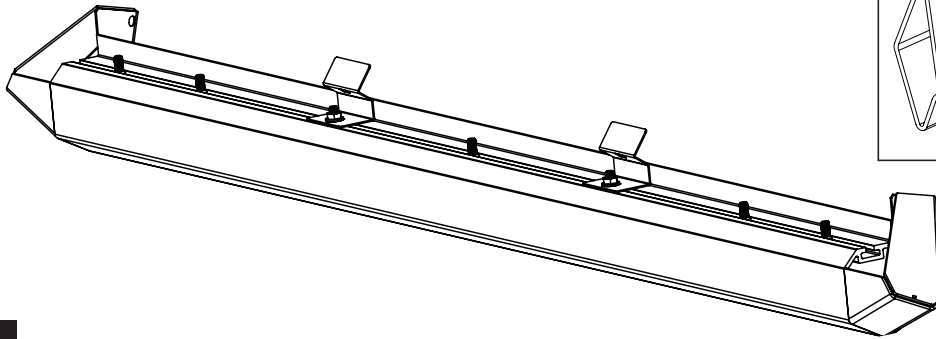

1

Using Flange Nuts (18), assemble Brackets 2x (27) & 1x (28) onto the rail (4), using the carriage bolts (17) left from previous step. Next, install Flange Bolt (15) and Flange Nut (18) onto bracket tab. Driver side shown. Dimensions shown are for reference.

Do not tighten this will allow for rail adjustment when mounted onto vehicle.

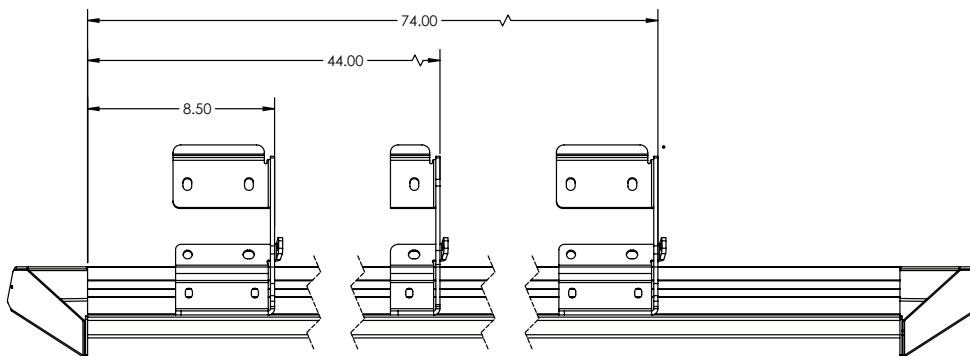

2

Note: Badge on rail sits towards the rear of the vehicle!

Set rail up into position. Starting with the rear bracket work towards the two front brackets. Insert U nuts (21) into position. Use provided button head bolts (9) with washers (10) and Flange Nut (11) on lower set of mount holes and Hex Bolt w conical washer (8) on upper set of holes of brackets. Snug to body

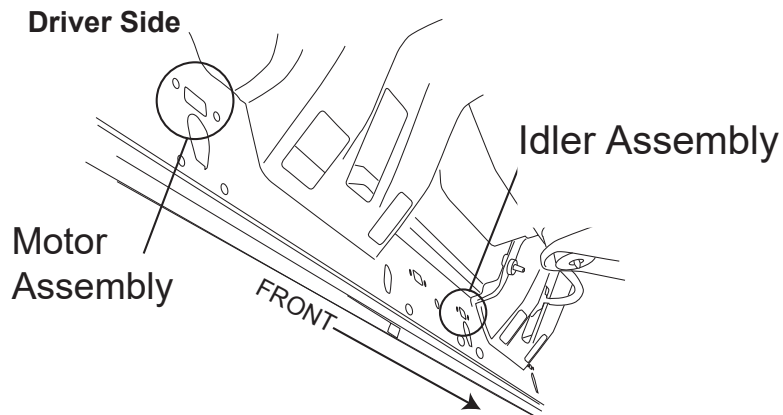

3

AMP RESEARCH POWERSTEP XL™ – FORD SuperDuty

Thread supplied bolts 2x (8) into Rear Drive Linkage. Repeat step for Front Idler Linkage. Do not tighten.

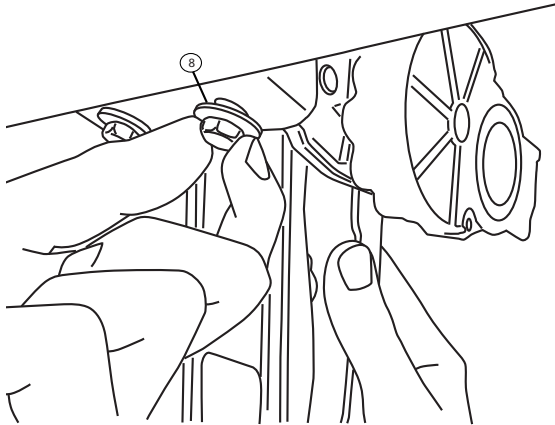

4

Install provided spacer (19) and M6 bolt (14) into upper mount as shown on both the Drive and Idler linkages. Do not tighten.

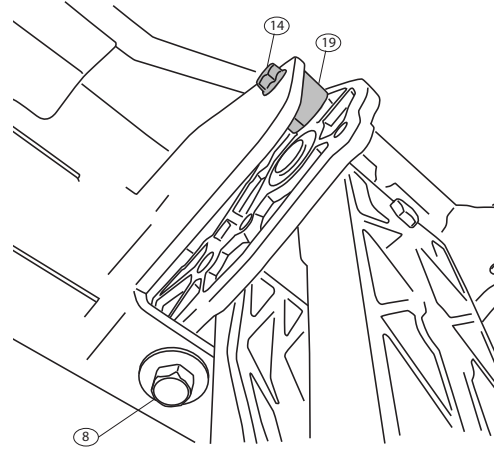

5

Slide mounting T-nut into position, Center board in rail pocket. Tighten fasteners to 10 ft-lbs.

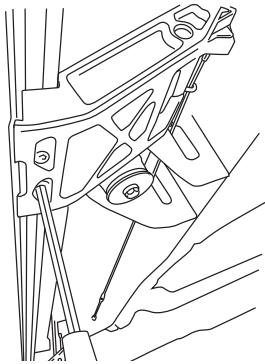

6

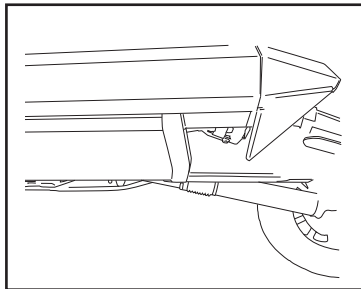

7

Using a 13mm socket Torque linkage bolts 4x (8) from step 3 to 16 ft-lbs. Next use a 10mm socket, torque linkage spacer bolt 2x (14) from step 6 to 8 ft-lbs. Once linkages are tight cycle board to verify steps deploy under own weight.

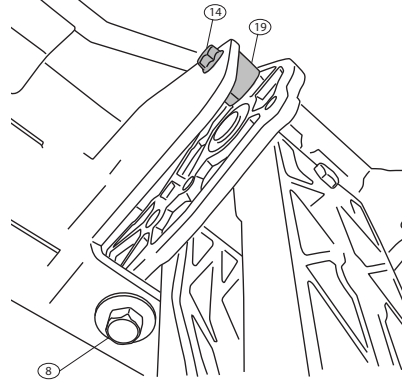

Start from rear of vehicle tighten brackets to the body of the vehicle. First Torque Button Head Bolts(9) to 16ft-lbs and then tighten Captive washer bolts(8) to 16 ft-lbs.

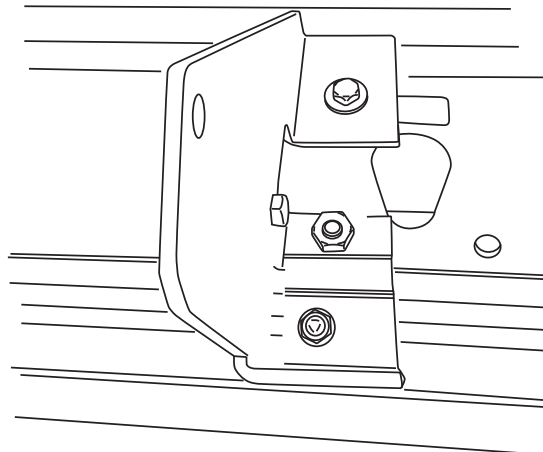

8

AMP RESEARCH POWERSTEP XL™ – FORD SuperDuty

Attach motor to harness. Using a 4mm hex Torque to 36 in-Lbs.

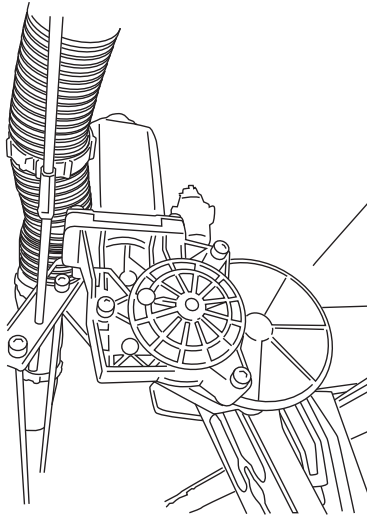

9

Torque bolts on mounting brackets as shown to 16ft-lbs.

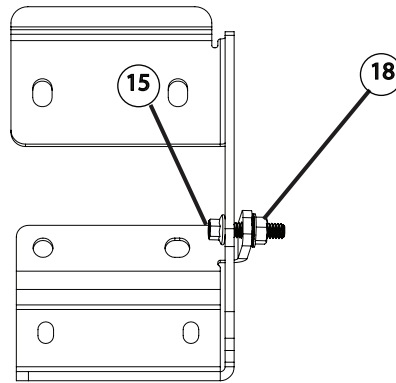

10

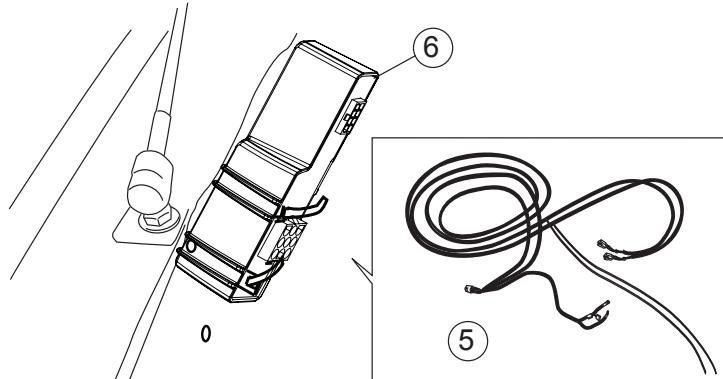
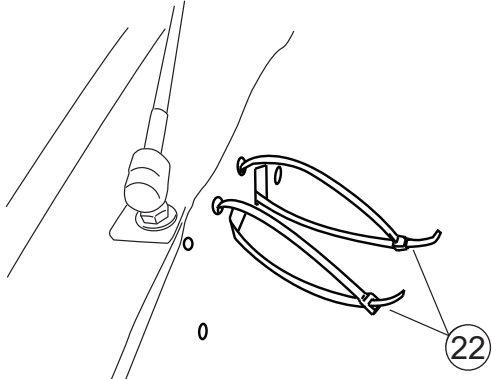

Loop two large tie wraps through fastener cutouts in sheet metal as shown. Position controller as shown above and cinch down tie wraps to secure controller in place. Connect harness to controller. Make sure that locking tabs on controller/harness connector are fully engaged.

11

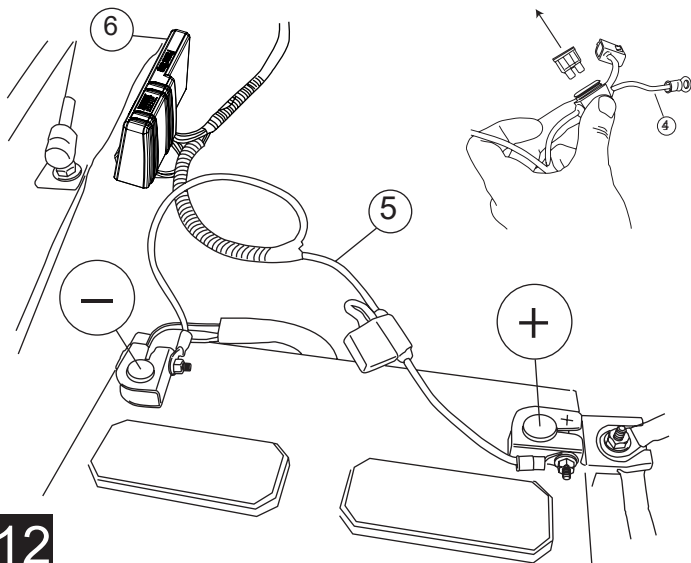

12

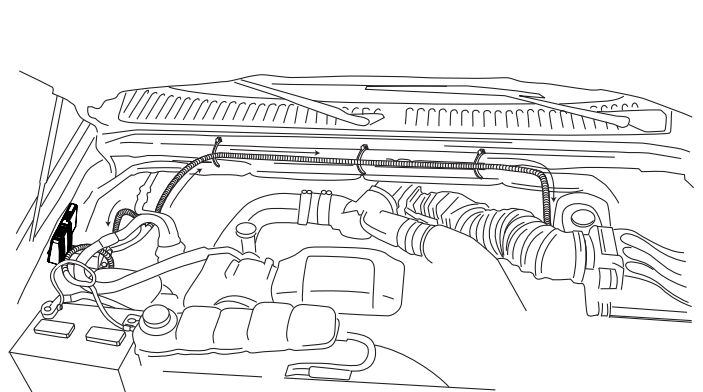

13

Puncture grommet and thread trigger wire

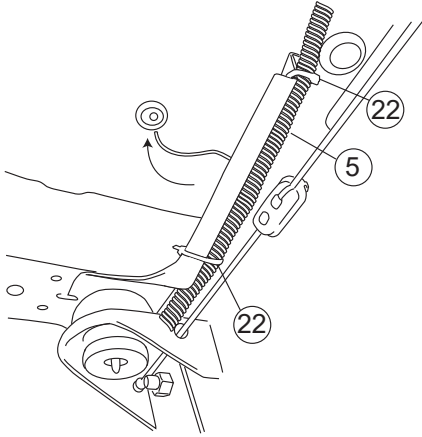

14

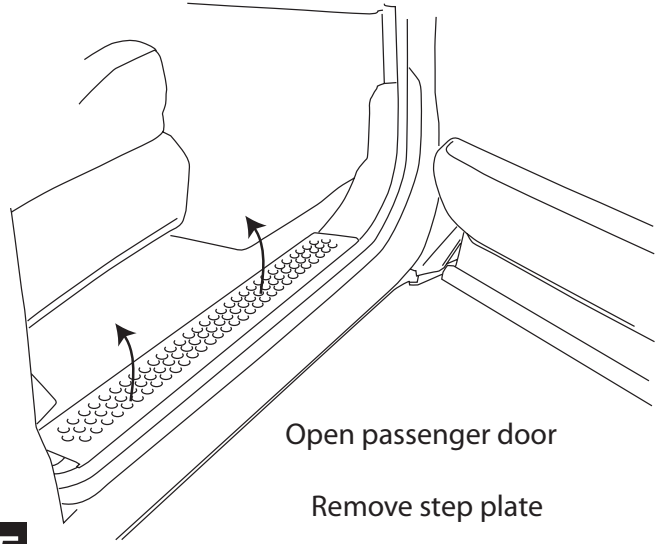

Open passenger door
Remove step plate

15

Remove kick plate

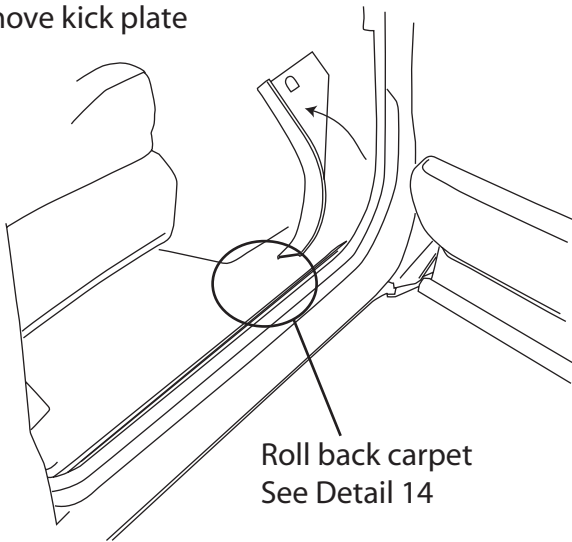

Roll back carpet
See Detail 14

16

Roll back carpet and pull trigger-wire through grommet.

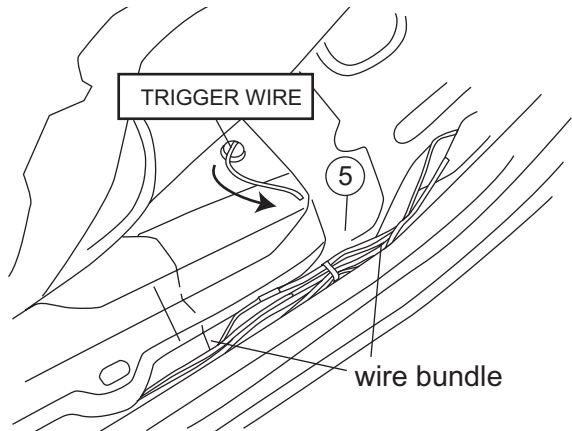

(See Wiring Guides for wiring details)

17

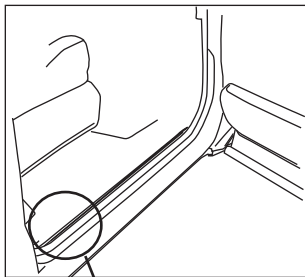

Roll back carpet
See Detail

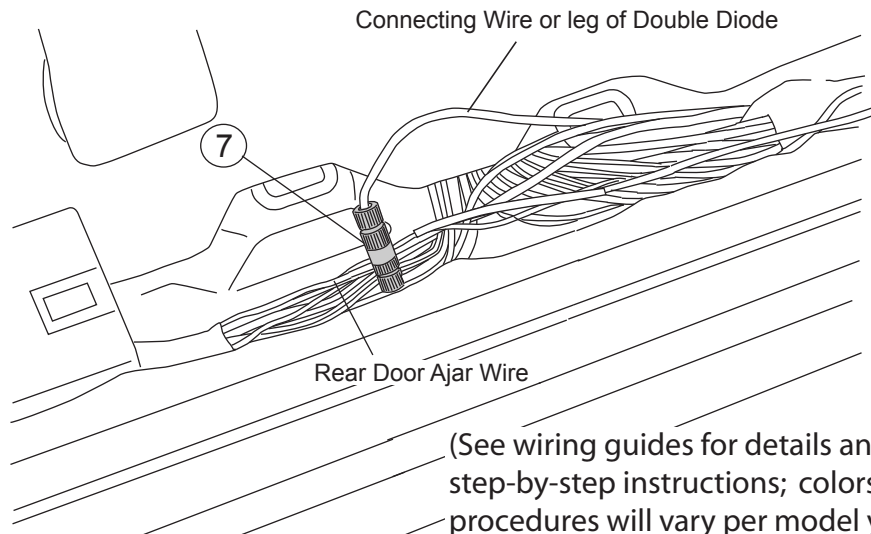

(See wiring guides for details and step-by-step instructions; colors and procedures will vary per model year)

18

NOTE: Steps 19-28, removing driver's door panel, only for vehicles prior to 2007.

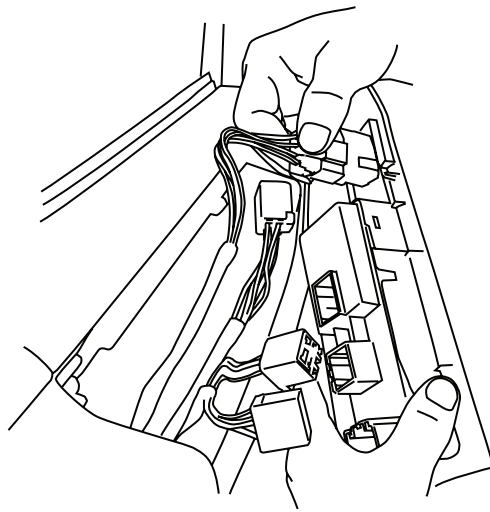
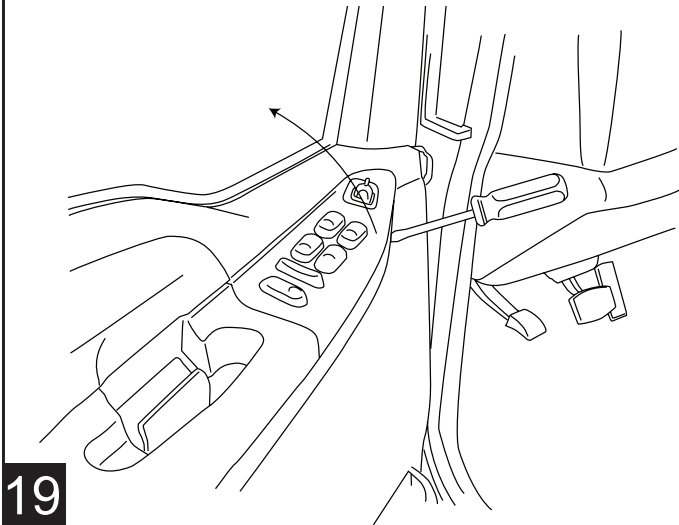

Remove door light

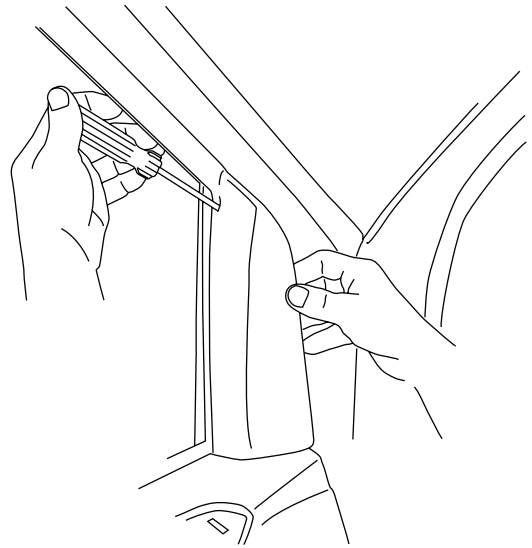
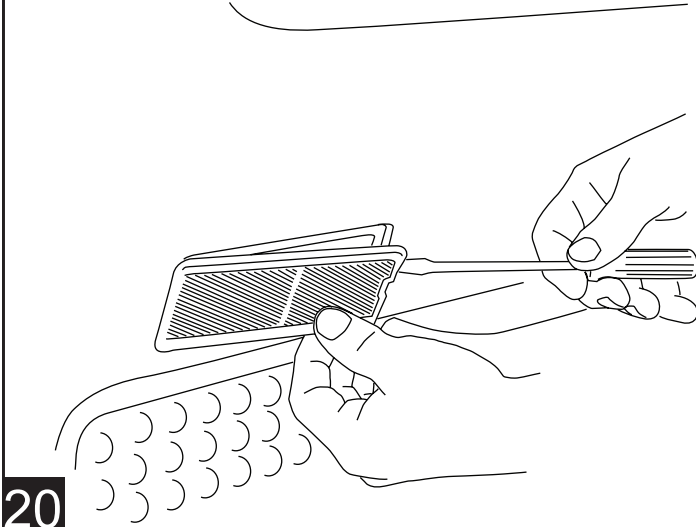

Remove speaker screws

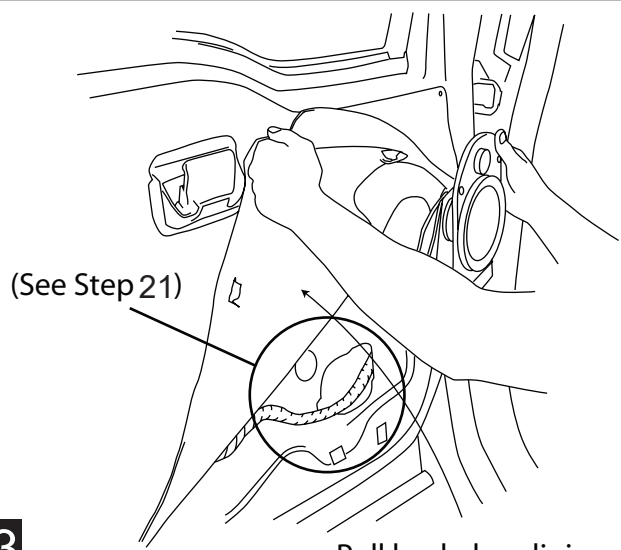
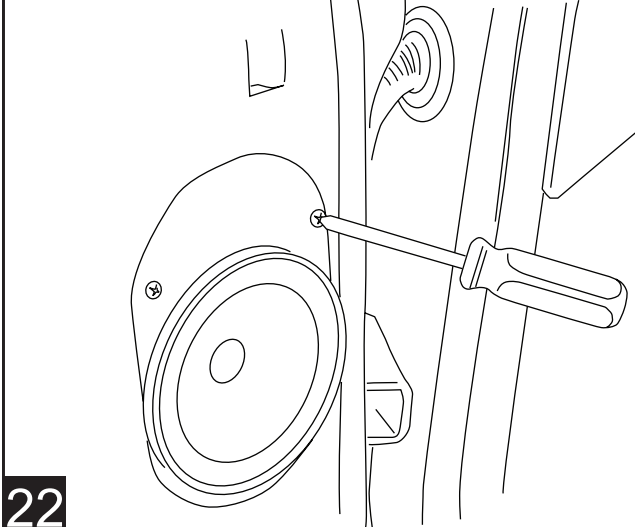

Pull back door lining

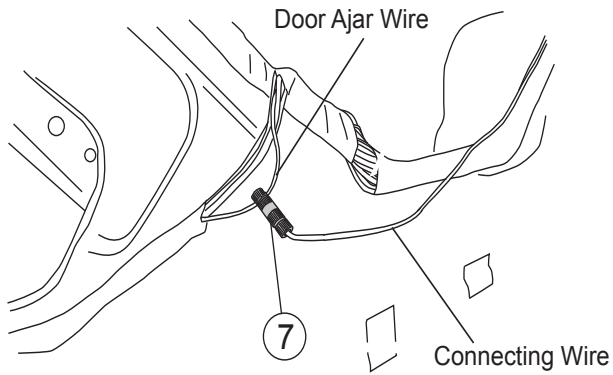

(See wiring guides and step-by-step instructions; colors and procedures will vary per model year)

24

Insert plastic tube

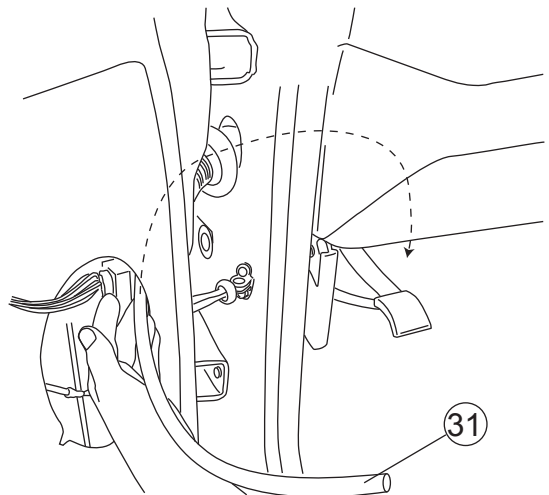

25

Thread wire through tube then remove tube

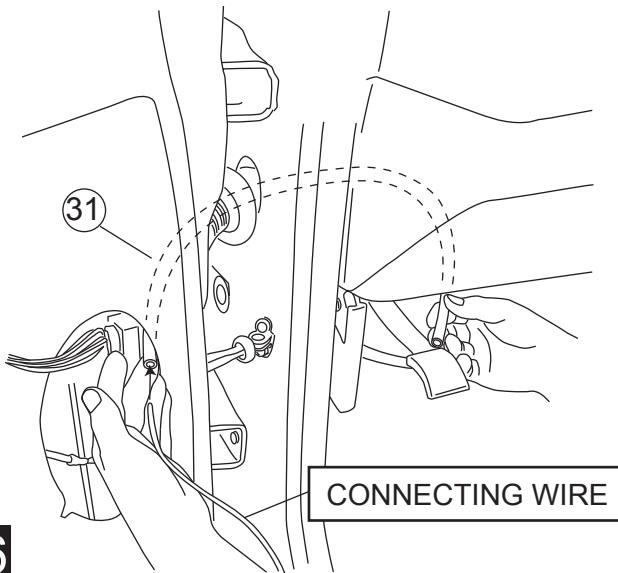

26

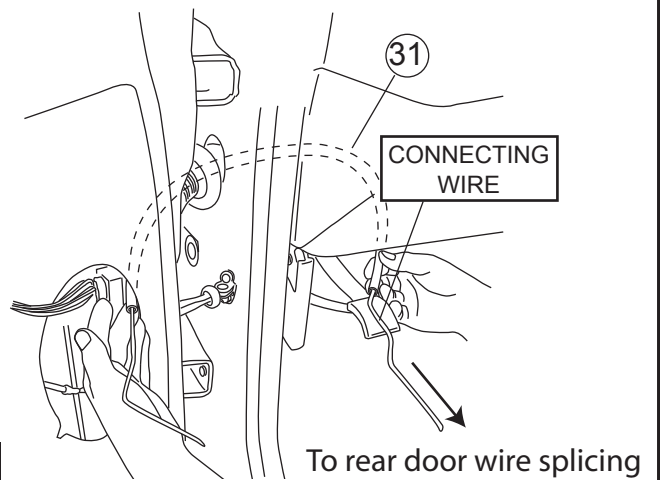

27

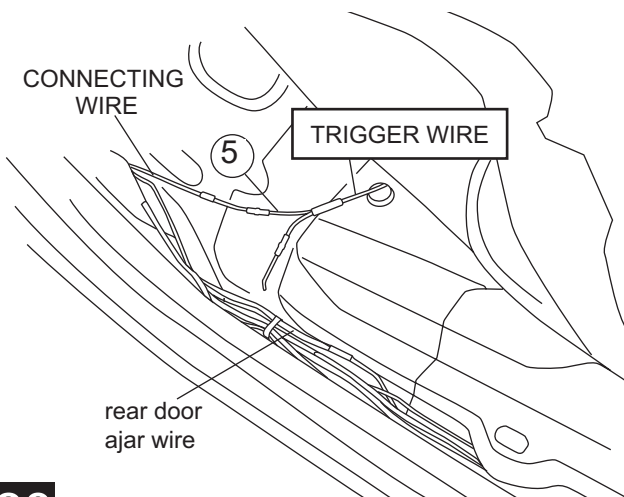

28

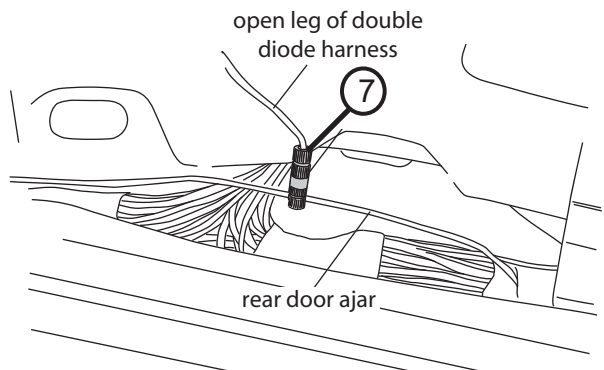

AMP RESEARCH POWERSTEP XL™ – FORD SuperDuty

Connect harness to motor. Secure harness with tie wraps.

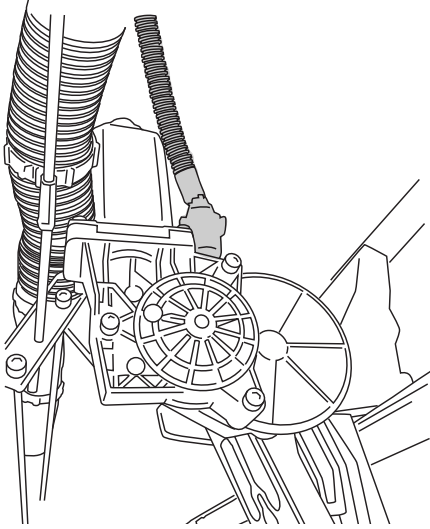

29

Affix LED lamp (23) to LED Bracket (25) as shown. Slide bracket into desired position and tighten using 5/32" Allen key.

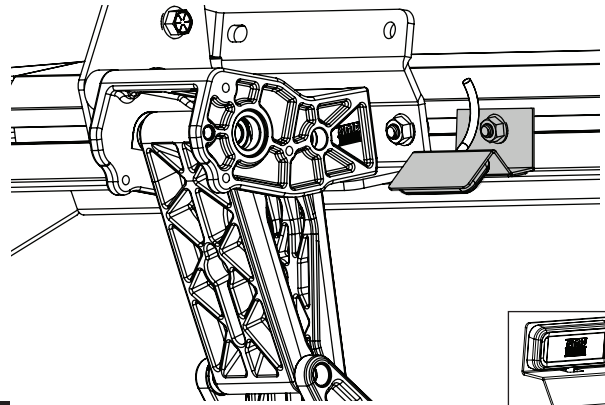

30

Using supplied butt connectors (24), connect the lamp wires. Red to Red, Black to Black. Once Crimped use heat gun to shrink tube. Close and wrap conduit with electrical tape. Secure all loose wires with cable ties. Pull lamp wires upward to avoid any wire snagging.

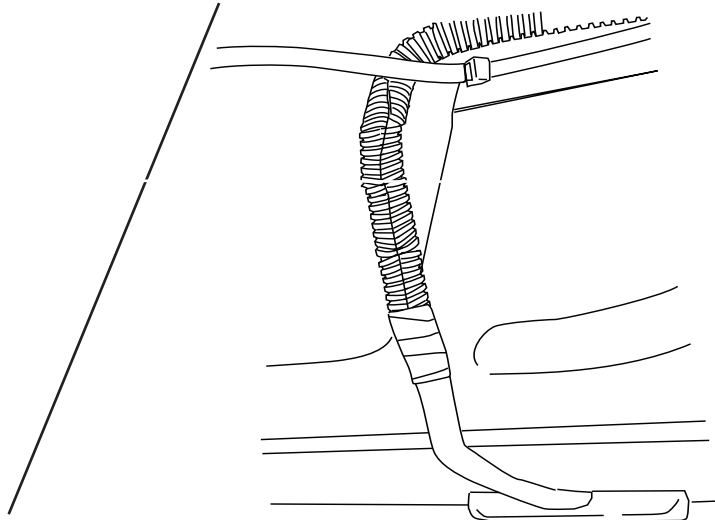
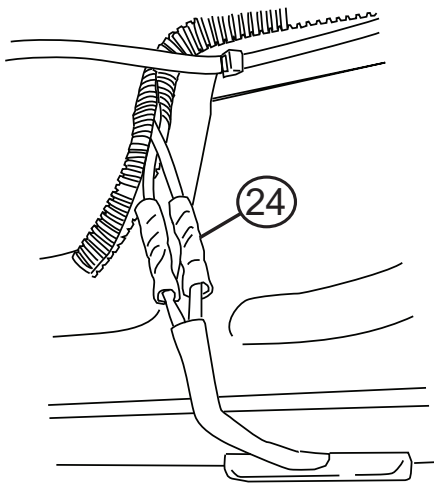

31

Reinstall fuse.

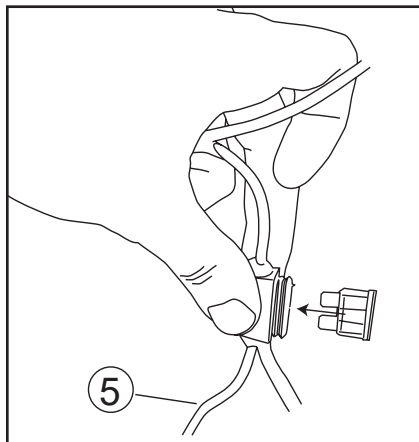

32

Check that all doors activate the Power Step and the LED Lights work when doors open and close. Reinstall any remaining trim panels.

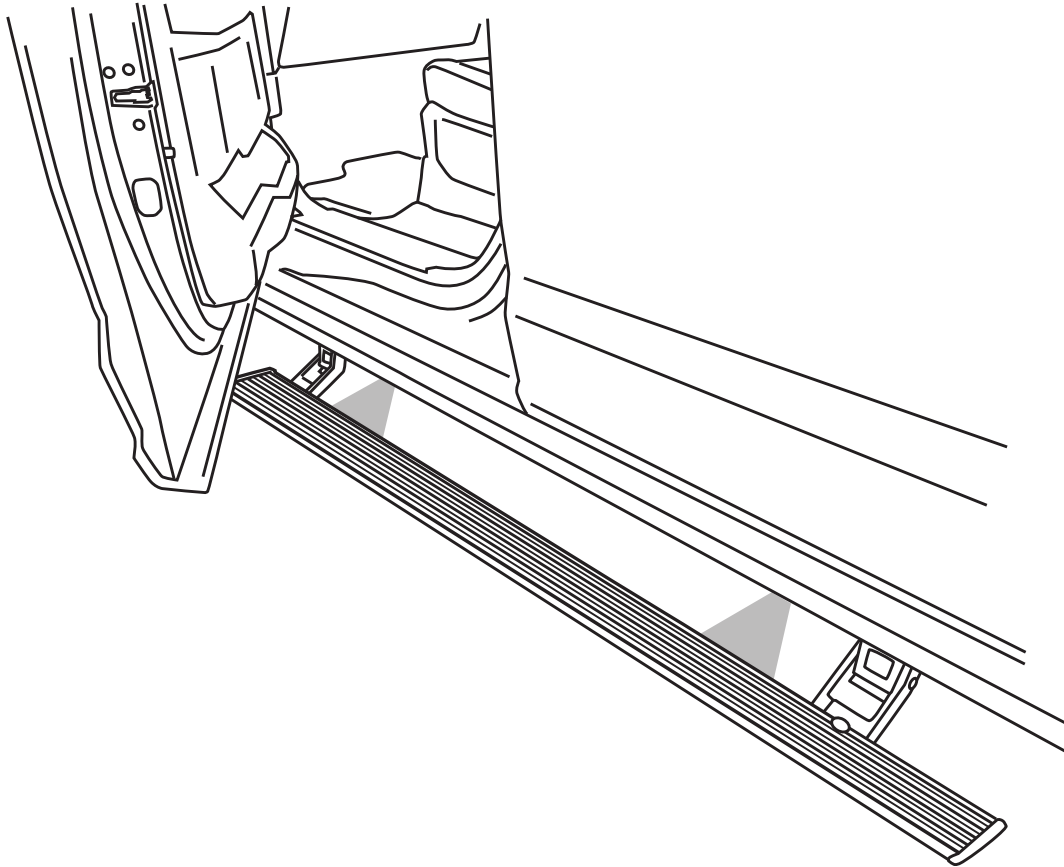

FINAL SYSTEM CHECK

Check that all doors activate the PowerStep and the LED lights work when doors open and close.

NORMAL OPERATION: When the doors open, PowerStep automatically deploys from under the vehicle. When the doors are closed, PowerStep will automatically return to the stowed/retracted position. **Note that there is a 2-second delay before the PowerStep returns to the stowed/retracted position.**





CORRECT OPERATION OF LIGHTS: All four lamps will illuminate upon opening any door of vehicle. Lamps will stay on until restowing of both Power Steps or until 5 minutes has expired with the doors open. When the lights timeout after 5 minutes, they can be reilluminated by closing and opening any door of vehicle.

AMP RESEARCH Power Step

MADE IN USA

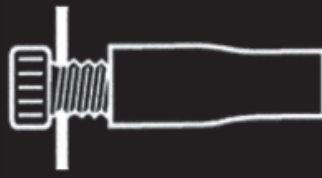
WIRING GUIDE / General instructions

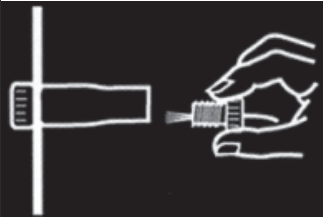
Posi-Tap™ installation instructions

 <p>1. Insert</p>	 <p>2. Tighten</p>	 <p>3. Strip 3/8"</p>
 <p>4. Insert & Tighten</p>	 <p>For two or more wires twist.</p>	<p>Posi-Tap™ Patents: 5,228,875; 5,695,369; 5,868,589, 2,708. Other patents pending.</p>

Diodes

NOTE: 2004-2006 Ford Super Duty trucks **without** remote keyless plus 2001 and older Super Duty trucks **with** remote keyless entry require additional diodes that are not included in the standard parts kit. See specific model year Wiring Guides for quantities required for your application. If needed, additional diodes (Part # Single 19-02727-90 / Double 19-02890-90) may be ordered at no charge and shipped UPS Ground by calling 1-888-983-2204

CAUTION

- ❑ Handle the motor and linkage assemblies with care when installing. Dropping can damage motor.
- ❑ Remove fuse from wiring harness during installation. Failure to do so could result in severe electrical shock.

TECH SUPPORT 1-888-983-2204 (press 2) Monday - Friday, 6:00 AM - 5:00 PM PST



Designed and manufactured by AMP Research. Patent 6,830,257 / 6,641,158 / 6,834,875 / 6,938,909 / 6,942,233 / 7,007,961 Other US and worldwide patents pending.. 5-year limited warranty. Professional installation is recommended.

WIRING GUIDE
Ford Super Duty (2007)
With remote keyless entry

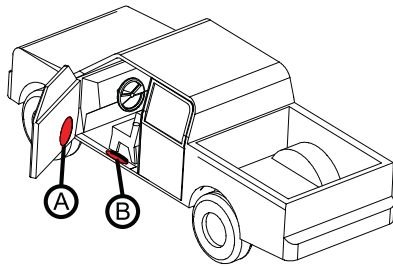
07
W

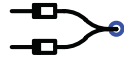

Driver-side wiring

-  **Posi-Tap™ connector**
-  **Double diode harness**
-  **Additional connecting wire (Red - 18 Ga)**
-  **Butt connector**

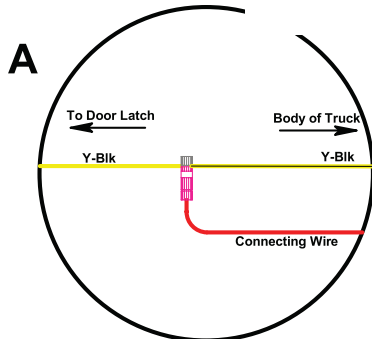

Front Door Panel

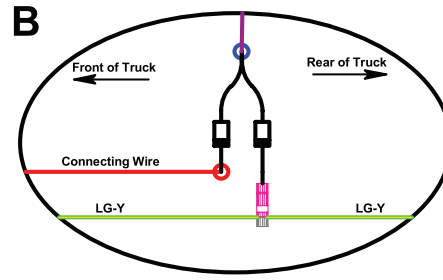

Front Sill Plate

DRIVER SIDE WIRING

1. Remove front kick panel and locate bundle of wires leaving front door just above e-brake assembly (Area-A). Open bundle and locate 18Ga door-ajar wire (yellow with black stripe).

Caution: You may find two wires with these colors; the correct wire will ground when the door is open (ohm meter will read low resistance with door open and OL (open line) with the door closed).

2. Using supplied Posi-Tap connectors, splice supplied red connecting wire into yellow with black stripe wire.

3. Route red wire down to sill plate.

4. Attach purple Power step trigger wire to blue butt connector of "double diode harness".

5. Attach one leg of "double diode harness" to open end of red connecting wire.

6. Using supplied Posi-Tap connectors, splice remaining leg of "double diode harness" into rear door-ajar wire (light green with yellow stripe) **Caution: You may find two wires with these colors; the correct wire will ground when the door is open (ohm meter will read low resistance with door open and OL (open line) with the door closed).**

Passenger-side wiring

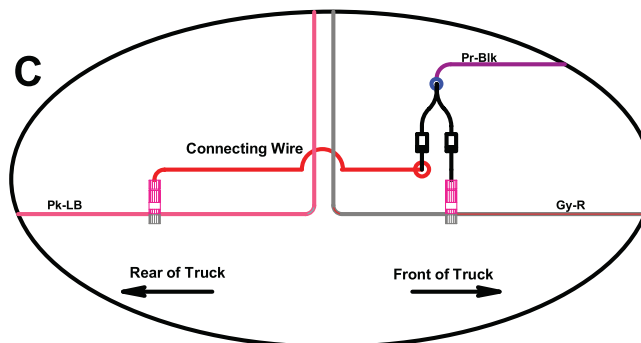

Front Sill Plate (Passenger Side)

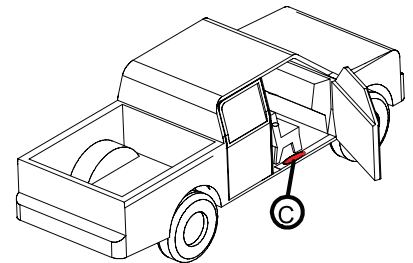

PASSENGER SIDE WIRING

1. Remove sill plate and attach purple Power Step trigger wire to blue butt connector of "double diode harness".

2. Open wire bundle and locate door-ajar wires (rear: pink with light blue stripe; front: grey with red stripe. Both wires pass under front seat as shown in figure-C

3. Using supplied Posi-Tap connectors, splice the open legs of the "double diode harness" into the door-ajar wires.

4. If necessary, attach red connecting wire to "double diode harness" to extend length as needed.

Notes:

1. All of the signal wires we tap into will be 18Ga. Do not tap into anything with a thicker gage than this.

2. Occasionally the wire colors do not match the wire schematics. Under these circumstances you will need to locate the door-ajar signal wires. Each door will have one wire leading out to its latch and one ground wire coming away. The ground wire will usually be solid black. The signal wire we need is the other wire.

3. Make sure you secure all wires after install. Loose wires can be damaged and may cause a failure in the Powerstep's function.

WIRING GUIDE
Ford Super Duty (2004 - 2006)
With remote keyless entry

04 - 06
W

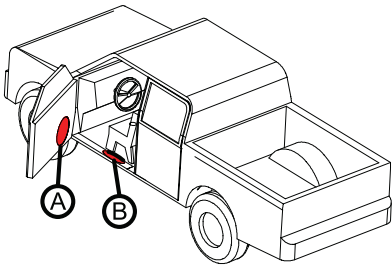

Driver-side wiring

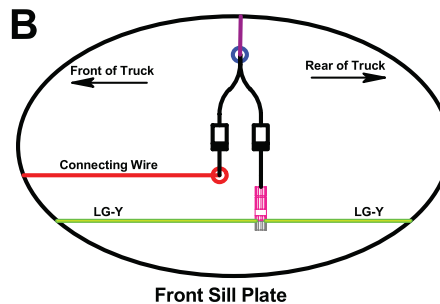
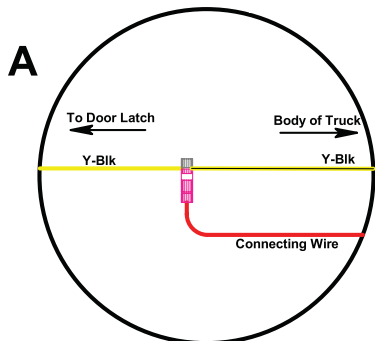
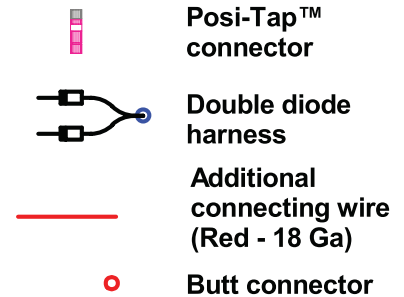

DRIVER SIDE WIRING

Front Door Panel

Front Sill Plate

1. Remove front door panel and locate bundle of wires below and to the left of speaker (Area-A). Open bundle and locate 18Ga door-ajar wire (yellow with black stripe). **Caution: You may find two wires with these colors; use wire that leads out to door latch.**
2. Using supplied Posi-Tap™ connectors, splice supplied red connecting wire into yellow with black stripe wire.
3. Route red wire back into cab of vehicle.
4. Attach purple Power Step trigger wire to blue butt connector of "double diode harness".

5. Attach one leg of "double diode harness" to open end of red connecting wire.
6. Using supplied Posi-Tap™ connectors, splice remaining leg of "double diode harness" into rear door-ajar wire (light green with yellow stripe). **CAUTION: You will find two wires with these colors; the correct wire will ground when the door is open (ohm meter will read low resistance with door open and OL with door closed).**

Passenger-side wiring

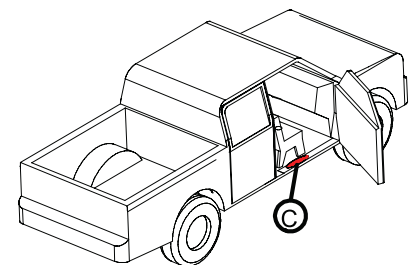
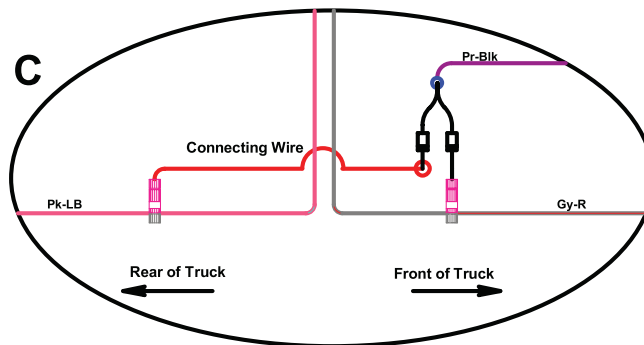

Front Sill Plate (Passenger Side)

PASSENGER SIDE WIRING

1. Remove sill plate and attach purple Power Step trigger wire to blue butt connector of "double diode harness".
2. Open wire bundle and locate door-ajar wires (rear: pink with a light blue stripe; front: grey with red stripe). Both wires pass under the front seat as shown in figure-C.

3. Using supplied Posi-Tap™ connectors, splice the open legs of "double diode harness" into door-ajar wires.
4. Attach Posi-Tap splice to this wire as shown in Figure-C. **NOTE: As shown above, you may have to use the supplied red connecting wire to extend to the installed Posi-Taps.**

Notes:

1. All of the signal wires we tap into will be 18Ga. Do not tap into anything with a thicker gage than this.
2. Occasionally the wire colors do not match the wire schematics. Under these circumstances you will need to locate the door-ajar signal wires. Each door will have one wire leading out to its latch and one ground wire coming away. The ground wire will usually be solid black. The signal wire we need is the other wire.
3. Make sure you secure all wires after install. Loose wires can be damaged and may cause a failure in the Powerstep's function.

WIRING GUIDE
Ford Super Duty (2004 - 2006)
Without remote keyless entry

SINGLE DIODES REQUIRED
 If diodes were not ordered with kit, they can be ordered at no charge and shipped UPS Ground by calling 1-888-983-2204

04 - 06
W/O

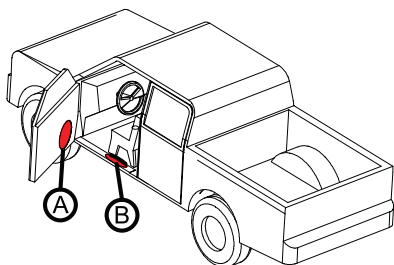

Driver-side wiring

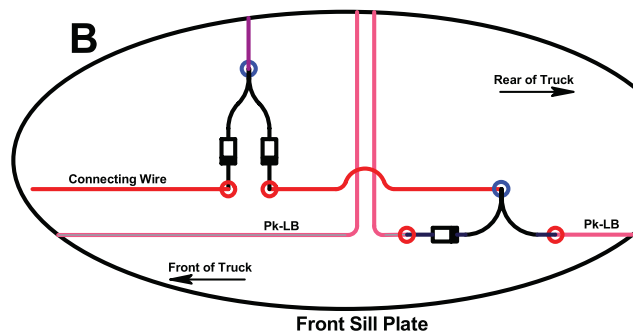
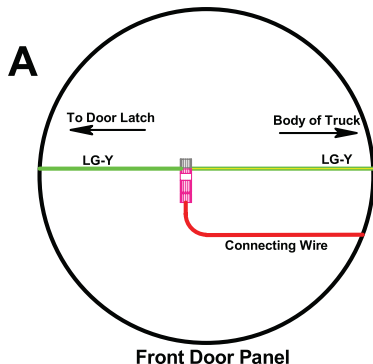

1. Remove front door panel and locate bundle of wires below and to the left of speaker (Area-A). Open bundle and locate 18Ga door-ajar wire (light green with yellow stripe). **Caution: You may find two wires with these colors; use wire that leads out to door latch.**

2. Using supplied Posi-Tap™ connectors, splice supplied red connecting wire into light green with yellow stripe wire.
3. Route red wire into cab of vehicle and back toward sill plate area.

4. Remove sill plate, open wire bundle and locate rear door-ajar wire (pink with a light blue stripe).

Caution: Make certain to locate the pink with light blue stripe wire rear of the junction where the wires cross under front seat. See figure B..

5. Cut wire and install "single diode harness" as oriented in Figure-B.
6. Attach red connecting wire routed from area-A to the open blue butt connector of "single diode harness" installed in step 5.
7. Attach blue connector of "double diode harness" to the purple signal wire of Powerstep harness that was pulled through the floor.
9. Cut the red connecting wire near the "double diode harness". Use butt connectors to connect each cut end of the connecting wire to the open legs of the "double diode harness".

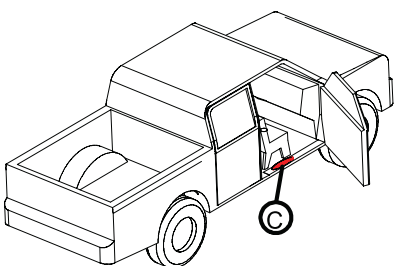
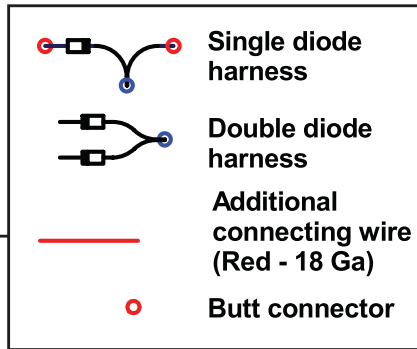

Passenger-side wiring

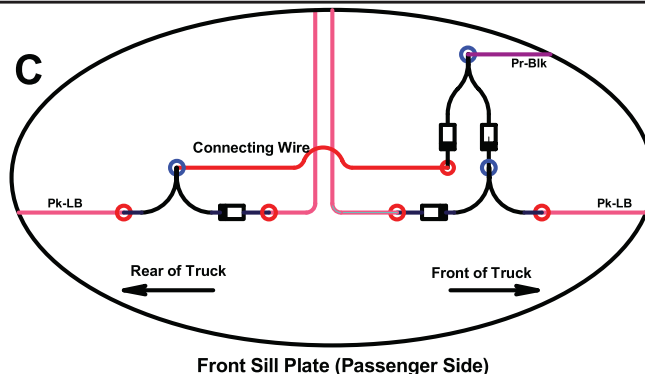

1. Remove front sill plate, open wire bundle and locate rear door-ajar wire (pink with a light blue stripe). This wire will be located rear of the junction where the wires route under the front passenger seat.

2. Cut wire and install "single diode harness" as oriented in Figure-C.
3. Locate front door-ajar wire (also pink with a light blue stripe). This wire will be located in front of the junction where the wires route under the front passenger seat.

4. Cut wire and install "single diode harness" as oriented in the figure above.
5. After both "single diode harnesses" have been installed, attach the supplied connecting wire to the blue connector of the rear "single diode harness".
6. After trimming to length, attach the opposite end of the connecting wire and the purple signal wire of the Powerstep harness to the blue connector on the front "single diode harness".

Notes:

1. All of the signal wires we tap into will be 18Ga. Do not tap into anything with a thicker gage than this.
2. Occasionally the wire colors do not match the wire schematics. Under these circumstances you will need to locate the door-ajar signal wires. Each door will have one wire leading out to its latch and one ground wire coming away. The ground wire will usually be solid black. The signal wire we need is the other wire.
3. Make sure you secure all wires after install. Loose wires can be damaged and may cause a failure in the Powerstep's function.

WIRING GUIDE
Ford Super Duty (2002 - 2003)
With remote keyless entry

NOTE: The two wires to each of the motor plugs (orange and white) must be reversed.

02 - 03

W

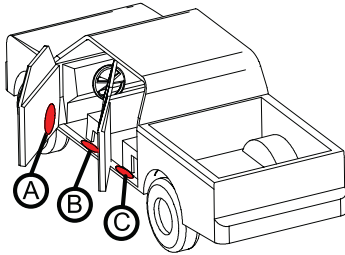

Driver-side wiring



Posi-Tap™ connector



Additional Connecting Wire (Red - 18 Ga)



Butt Connector

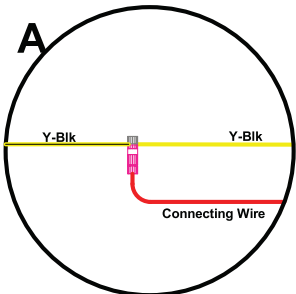

Front Door Panel

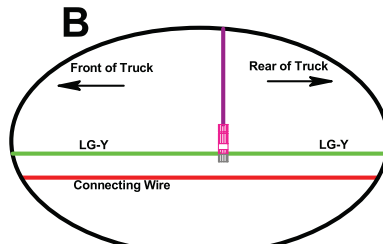

Front Sill Plate

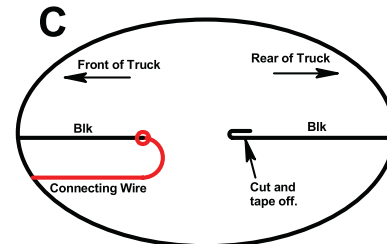

Rear Sill Plate

DRIVER SIDE WIRING

1. Remove front door panel and locate bundle of wires below and to the left of speaker (Area-A). Open bundle and locate 18 Ga door-ajar wire (yellow with black stripe).
CAUTION: You may find two wires with these colors; use wire that leads out to door latch.
2. Using supplied Posi-Tap™ connectors, splice supplied red connecting wire into yellow with black stripe wire.
3. Route red wire back into cab of vehicle and back toward rear sill plate.

4. Remove rear sill plate, open wire bundle and locate 18 Ga. black wire. Cut this wire and attach the end of the connecting wire from step-3 as shown in figure-C.
5. Using supplied Posi-Tap™ connectors, splice purple Power Step trigger wire into rear door-ajar wire (light green with yellow stripe), located under front sill plate.
CAUTION: You will find two wires with these colors; the correct wire will ground when the door is open (ohm meter will read low resistance with door open and OL with door closed).

Passenger-side wiring

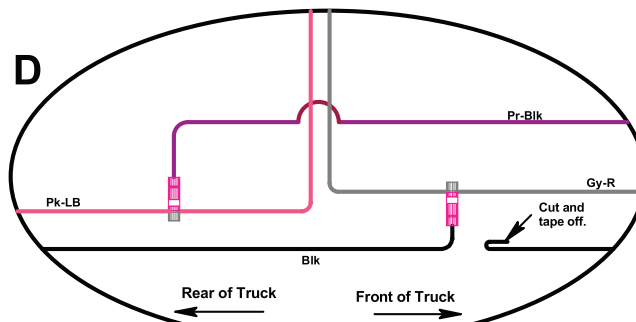

Front Sill Plate (Passenger Side)

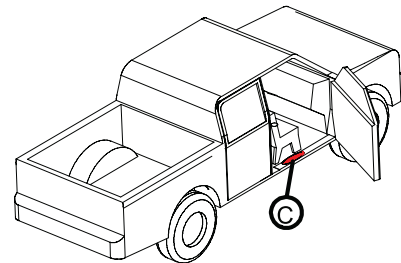

PASSENGER SIDE WIRING

1. Remove passenger side front sill plate, open wire bundle and locate rear door-ajar wire (pink with light blue stripe). This wire will be located rear of junction where wires route under from passenger seat.
2. Using supplied Posi-Tap™ connectors, splice purple Power Step trigger wire into pink with light blue stripe wire.

3. Cut the black 18 Ga wire found in wire bundle, forward of junction where wires route under front seat.
4. Using supplied Posi-Tap™ connectors, splice rear section of cut black wire into front door-ajar wire (grey with red stripe) as shown above.
5. Tape off the remaining open end of the black wire (front section).

Notes:

1. All of the signal wires we tap into will be 18Ga. Do not tap into anything with a thicker gage than this.
2. Occasionally the wire colors do not match the wire schematics. Under these circumstances you will need to locate the door-ajar signal wires. Each door will have one wire leading out to its latch and one ground wire coming away. The ground wire will usually be solid black. The signal wire we need is the other wire.
3. Make sure you secure all wires after install. Loose wires can be damaged and may cause a failure in the Powerstep's function.

WIRING GUIDE
Ford Super Duty (2002 - 2003)
Without remote keyless entry

NOTE: The two wires to each of the motor plugs (orange and white) must be reversed.

02 - 03
W/O

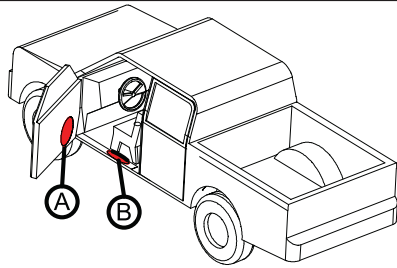

Driver-side wiring

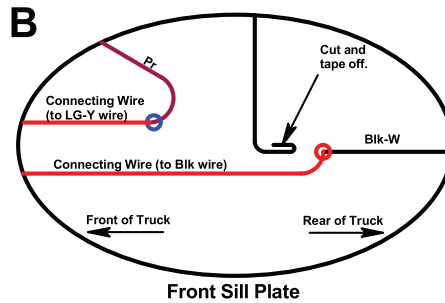
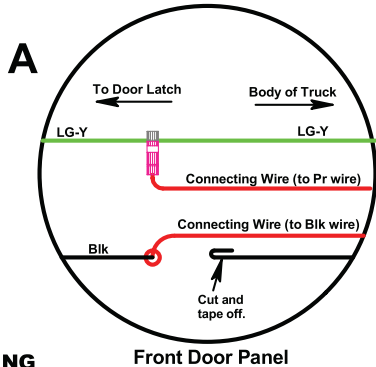
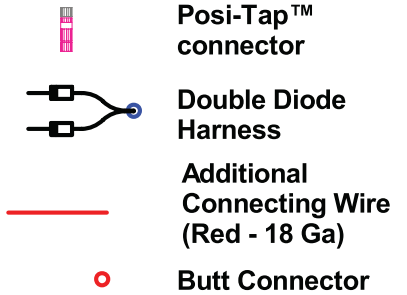

DRIVER SIDE WIRING

1. Remove door panel, access a bundle of wires below and to the left of speaker (Area-A). Open bundle and locate 18Ga. door-ajar wire (light green with yellow stripe).
2. Using supplied Posi-Tap™ connectors, splice supplied red connecting wire into light green with yellow stripe wire.
3. Locate black 18Ga. wire in the same area (Area-A). Cut wire and attach another connecting wire to one end as shown above. Tape off the open end as shown above.
4. Route both connecting wires through door and accordion back toward front sill plate (Area-B).

5. Open wire bundle under front sill plate and locate the door-ajar wire (black with a white stripe).
6. Cut this wire and connect the other end of the connecting wire that comes from the black wire of step 3 to the rearward end of the wire. Tape off the open end of the cut wire as shown in Figure-B.
7. Attach the other connecting wire (from yellow with black stripe wire) to the purple signal wire from the Powerstep harness.

Passenger-side wiring

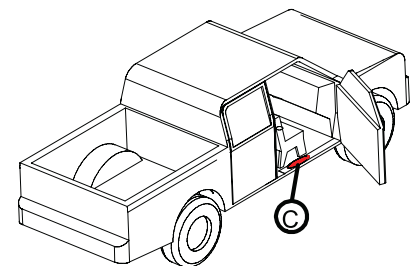
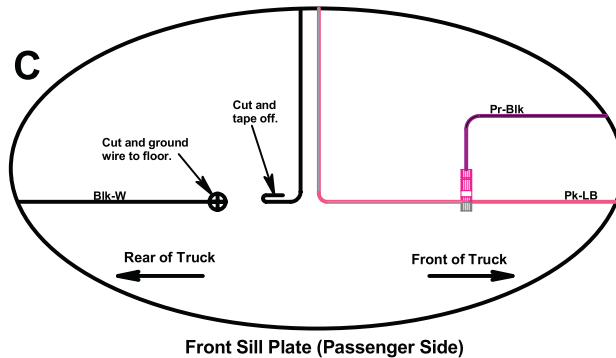

PASSENGER SIDE WIRING

1. Remove front sill plate of passenger side, open wire bundle and locate front door-ajar wire (pink with a light blue stripe). This wire will be located forward of the junction where the wires route under the passenger seat.
2. Using supplied Posi-Tap™ connectors, splice purple Power Step trigger wire into light pink with light blue stripe wire.

3. Locate the ground wire for the rear door-ajar wire (black with a white stripe). This wire will be located rear of junction where the wires route under the passenger front seat.
4. Cut this wire (black with white stripe) and ground the one end as shown above to the vehicle's ground (suggestion: use ring terminal and sheet metal screw or extend wire to a grounded terminal). Tape off open end.

Notes:

1. All of the signal wires we tap into will be 18Ga. Do not tap into anything with a thicker gage than this.
2. Occasionally the wire colors do not match the wire schematics. Under these circumstances you will need to locate the door-ajar signal wires. Each door will have one wire leading out to its latch and one ground wire coming away. The ground wire will usually be solid black. The signal wire we need is the other wire.
3. Make sure you secure all wires after install. Loose wires can be damaged and may cause a failure in the Powerstep's function.

WIRING GUIDE
Ford Super Duty (2001)
With remote keyless entry

SINGLE DIODES REQUIRED
 If diodes were not ordered with kit, they can be ordered at no charge and shipped UPS Ground by calling 1-888-983-2204

99 - 01
W

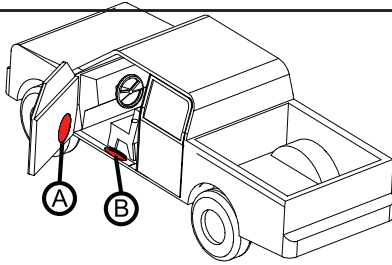

Driver-side wiring

NOTE: On 2001 and older models the factory harness does not split and cross over from passenger to driver side under front seats, but does on all other model years.

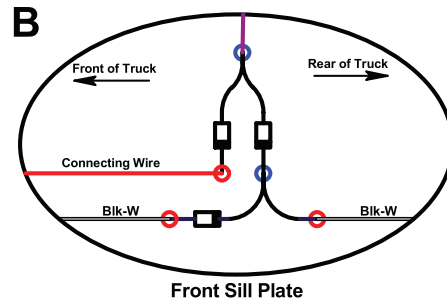
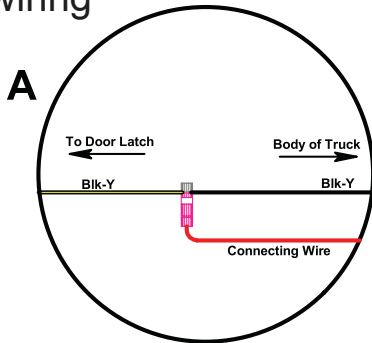
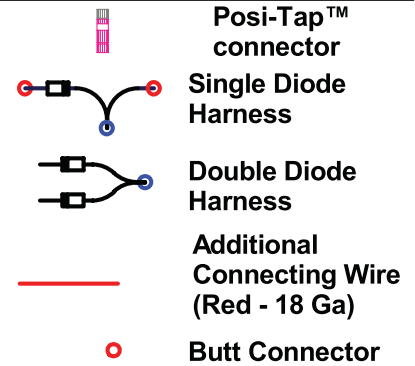

DRIVER SIDE WIRING

Front Door Panel

1. Remove front door panel and locate bundle of wires below and to the left of speaker (Area-A). Open bundle and locate 18Ga door-ajar wire (black with yellow stripe). **Caution: You may find two wires with these colors; use wire that leads out to door latch.**
2. Using supplied Posi-Tap™ connectors, splice supplied red connecting wire into black with yellow stripe wire.
3. Route red wire back into cab of vehicle.
4. Attach purple Power Step trigger wire to blue butt connector of "double diode harness".

4. After removing the front sill plate, open wire bundle and locate rear door-ajar wire (black with a white stripe).
5. Cut wire and install "single diode harness" as oriented in the Figure-B.
6. Connect blue connector of "double diode harness" to purple Power Step trigger wire that was pulled through the floor.
7. Attach connecting wire that comes from Area-A as shown in the figure using supplied red butt connector.
8. Attach the open blue connector of "single diode harness" to the remaining open leg of "double diode harness".

Passenger-side wiring

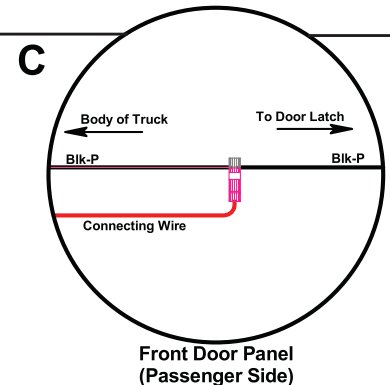
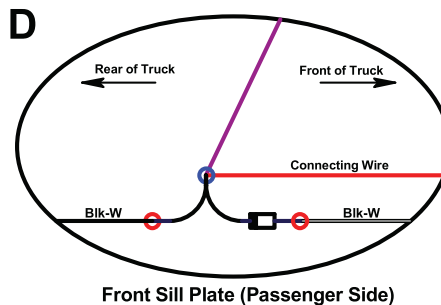
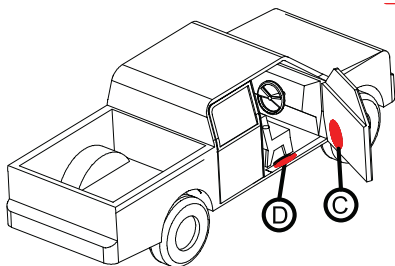

PASSENGER SIDE WIRING

1. Remove front passenger door panel and access a bundle of wires below and to the right of the speaker (Area-C). Open bundle and locate 18Ga door-ajar wire (black with a pink stripe).
2. Using supplied Posi-Tap™ connectors, splice supplied red connecting wire into black with pink stripe wire.
3. Route red wire back into cab of vehicle and down to sill plate.

4. Remove step plate (Area-D), open wire bundle and locate rear door-ajar wire (black with a white stripe).
5. Cut wire and install "single diode harness" as oriented in Figure-D.
6. Attach connecting wire from step-3 and purple signal wire from Powerstep harness to "single diode harness" as shown in Figure-D.

Notes:

1. All of the signal wires we tap into will be 18Ga. Do not tap into anything with a thicker gage than this.
2. Occasionally the wire colors do not match the wire schematics. Under these circumstances you will need to locate the door-ajar signal wires. Each door will have one wire leading out to its latch and one ground wire coming away. The ground wire will usually be solid black. The signal wire we need is the other wire.
3. Make sure you secure all wires after install. Loose wires can be damaged and may cause a failure in the Powerstep's function.

WIRING GUIDE

Ford Super Duty (2004 - 2006) Regular Cab & Extended Cab
With remote keyless entry

04 - 06

W

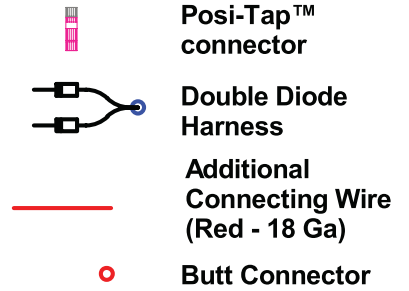
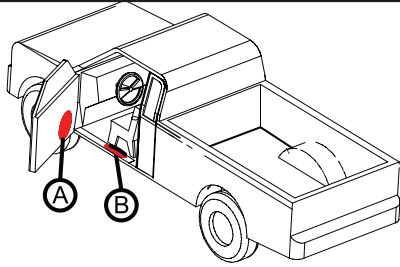

Driver-side wiring

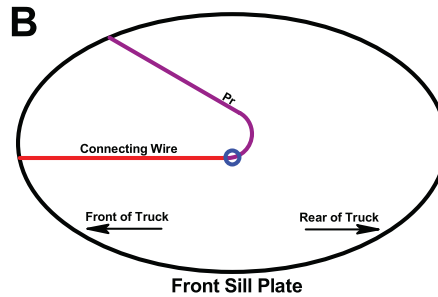
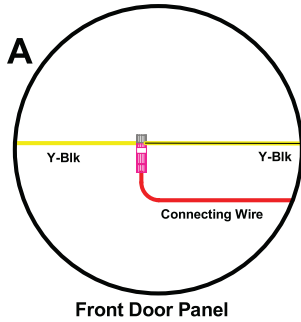

DRIVER SIDE WIRING

1. Remove front door panel and locate bundle of wires below and to the left of speaker (Area-A). Open bundle and locate 18Ga door-ajar wire (yellow with black stripe). **Caution: You may find two wires with these colors; use wire that leads out to door latch.**
2. Using supplied Posi-Tap™ connectors, splice supplied red connecting wire into yellow with black stripe wire.

3. Route red wire into cab of vehicle and back toward sill plate area.
4. After removing the front door step plate, attach the connecting wire to the purple signal wire from Powerstep harness that was pulled through the floor.

Passenger-side wiring

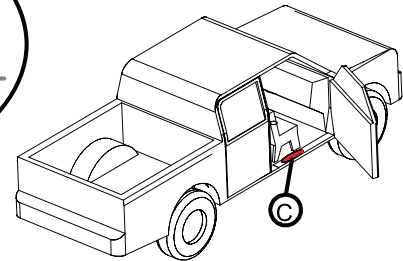
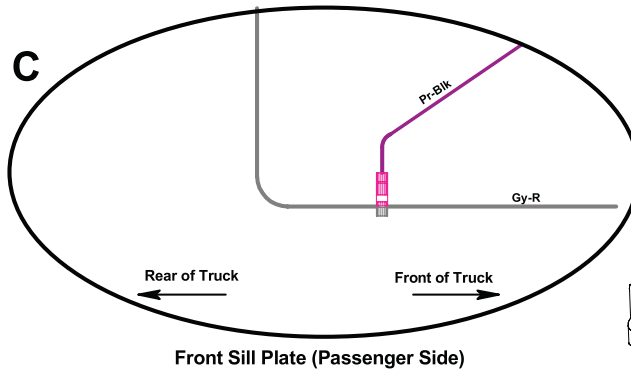

PASSENGER SIDE WIRING

1. Removing the passenger side front sill plate, open wire bundle and locate the rear door-ajar wire (gray with a red stripe).
2. Using supplied Posi-Tap™ connectors, splice supplied purple Power Step trigger wire into gray with red stripe wire.

Notes:

1. All of the signal wires we tap into will be 18Ga. Do not tap into anything with a thicker gage than this.
2. Occasionally the wire colors do not match the wire schematics. Under these circumstances you will need to locate the door-ajar signal wires. Each door will have one wire leading out to its latch and one ground wire coming away. The ground wire will usually be solid black. The signal wire we need is the other wire.
3. Make sure you secure all wires after install. Loose wires can be damaged and may cause a failure in the Powerstep's function.

WIRING GUIDE

Ford Super Duty (2002 - 2003) Regular Cab & Extended Cab
With remote keyless entry

02 - 03

W

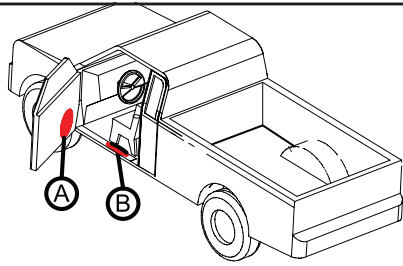

NOTE: The two wires to each of the motor plugs (orange and white) must be reversed.

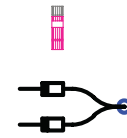

Posi-Tap™ connector

Double Diode Harness

Additional Connecting Wire (Red - 18 Ga)

Butt Connector

Driver-side wiring

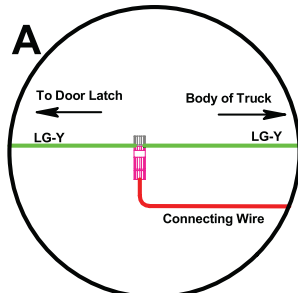

Front Door Panel

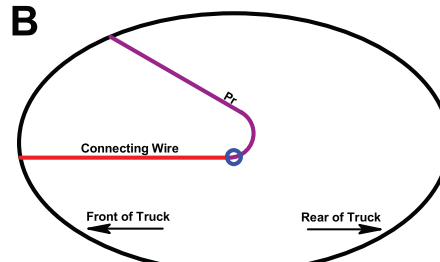

Front Sill Plate

DRIVER SIDE WIRING

1. Remove front door panel and locate bundle of wires below and to the left of speaker (Area-A). Open bundle and locate 18Ga door-ajar wire (light green with yellow stripe). **Caution: You may find two wires with these colors; use wire that leads out to door latch.**
2. Using supplied Posi-Tap™ connectors, splice supplied red connecting wire into light green with yellow stripe wire.

3. Route red wire into cab of vehicle and back toward sill plate area.
4. After removing the front door step plate, attach the connecting wire to the purple signal wire from Powerstep harness that was pulled through the floor.

Passenger-side wiring

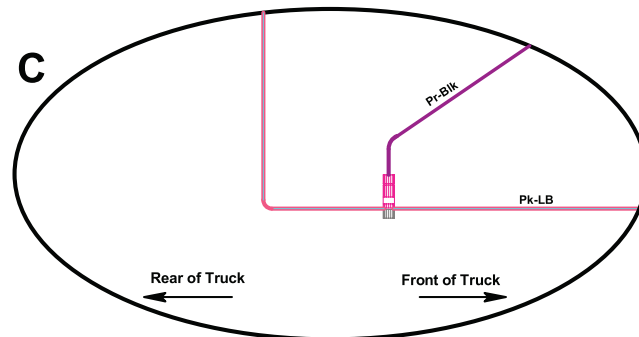

Front Sill Plate (Passenger Side)

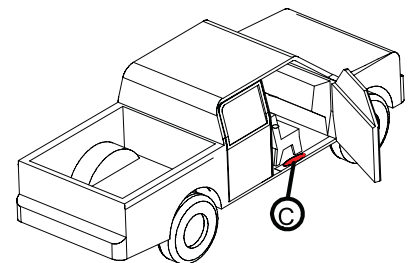

PASSENGER SIDE WIRING

1. Removing the passenger side front sill plate, open wire bundle and locate the rear door-ajar wire (pink with a light blue stripe).
2. Using supplied Posi-Tap™ connectors, splice supplied purple Power Step trigger wire into pink with light blue stripe wire.

Notes:

1. All of the signal wires we tap into will be 18Ga. Do not tap into anything with a thicker gage than this.
2. Occasionally the wire colors do not match the wire schematics. Under these circumstances you will need to locate the door-ajar signal wires. Each door will have one wire leading out to its latch and one ground wire coming away. The ground wire will usually be solid black. The signal wire we need is the other wire.
3. Make sure you secure all wires after install. Loose wires can be damaged and may cause a failure in the Powerstep's function.



AMERICAN DESIGNED, ENGINEERED AND MANUFACTURED.

Thank you for your recent AMP Research Purchase.

**REGISTER YOUR PRODUCT TODAY FOR
FASTER SERVICE & PRODUCT UPDATES**

Please visit:

www.amp-research.com/productregistration
or scan the QR Code



Product Registration Benefits:

- Ensure we have your purchase receipt and product info in our system which is required for warranty
- Faster and easier access to customer service and tech support in the unlikely event you need warranty or product support
- Registration helps us keep you up to date on product information and offers

To view other Amp Research products that may be offered for your vehicle.

Please visit: www.amp-research.com

Rev 01.05.21



Congratulations on your purchase of the genuine AMP Research PowerStep!
Here's what you should know...

POWER-DEPLOYABLE RUNNING BOARDS OPERATION: AMP Research PowerStep running boards automatically move when the doors are opened to assist entering and exiting the vehicle.



Automatic power deploy:

The running boards will extend down and out when the doors are opened.

Automatic power stow:

The running boards will return to the stowed position when the doors are closed. There will be a 2-second delay before the running boards move to the stowed position.

Automatic stop:

If an object is in the way of the moving running board, the running board will automatically stop. To reset, clear any obstruction, then simply open and close the door to resume normal operation.



Manually set in the deployed (OUT) position for access to the roof:

The running boards can be manually set in the deployed position by firmly holding the step down with your foot while at the same time closing the door. To resume normal operation, open and close the door.

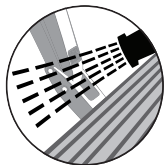

Maintenance: In adverse conditions, debris such as mud, dirt, and salt may become trapped in the running board mechanism, possibly leading to unwanted noise. If this occurs, manually set the running boards to the deployed position and flush the front and rear hinge arms with a high-pressure car wash wand.

Avoid spraying the motors directly. After washing, apply silicone spray lubricant to the hinge pivot pins. Do not apply silicone, wax or protectants like Armor All® to the running board stepping surface.

Caution! Keep hands away when the running board is in motion.

5-YEAR LIMITED WARRANTY

AMP RESEARCH warrants this product to be free from defects in material and workmanship for FIVE (5) YEARS FROM DATE OF PURCHASE, provided there has been normal use and proper maintenance. This warranty applies to the original purchaser only. All remedies under this warranty are limited to the repair replacement of the product itself, or the repair or replacement of any component part thereof, found by the factory to be defective within the time period specified. The decision to repair or replace is wholly within the discretion of the manufacturer.

This warranty specifically excludes labor. If you have a warranty claim, first you must call our factory at the number below for instructions. You must retain proof of purchase and submit a copy with any items returned for warranty work. Upon completion of warranty work, if any, we will return the repaired or replaced item or items to you freight prepaid. Damage to our products caused by accidents, fire, vandalism, negligence, misinstallation, misuse, Acts of God, or by defective parts not manufactured by us, is not covered under this warranty.

ANY IMPLIED WARRANTIES OF MERCHANTABILITY AND/OR FITNESS FOR A PARTICULAR PURPOSE CREATED HEREBY ARE LIMITED IN DURATION TO THE SAME DURATION AND SCOPE AS THE EXPRESS WRITTEN WARRANTY. OUR COMPANY SHALL NOT BE LIABLE FOR ANY INCIDENTAL OR CONSEQUENTIAL DAMAGE.

Some states do not allow limitations on how long an implied warranty lasts, or the exclusion or limitation of incidental or consequential damages, so the above limitations or exclusions may not apply to you. This warranty gives you specific legal rights, and you may also have other rights that vary from state to state.

FOR WARRANTY ISSUES WITH THIS PRODUCT PLEASE CALL AMP RESEARCH TECH SUPPORT 1-888-983-2204

WARNING

Be sure to read and precisely follow the provided instructions when installing this product. Failure to do so could place the vehicle occupants in a potentially dangerous situation. After installing or reinstalling, re-check to insure that the product is properly installed.



The material that your product is made from can be recycled. Please also consider recycling the packaging that your product came in.

