

ARB **BASE RACK**

FITTING INSTRUCTION

Part Number: 1780360 & 1780365
Product Description: **BASE RACK** Roller (suits 1155mm & 1285mm racks)

WARNING

- ◆ This product must be installed exactly as per these instructions using only the hardware supplied
- ◆ The roller is designed for loading/unloading assistance. It is not designed to support load during transit.
- ◆ This product is not compatible over guard rail clamps. For rear mount rollers “Full” rail kits cannot be used. Side mount rollers may be compatible with “1/4” rail kits.
- ◆ This product or its fixing must not be modified in any way
- ◆ These instructions are correct as at the publication date
- ◆ During installation, it is the duty of the installer to check correct operation/clearances of all components
- ◆ Work safely at all times
- ◆ Unless otherwise instructed, tighten fasteners to specified torque
- ◆ Fastener torques are to be checked at regular intervals

ARB 4x4 ACCESSORIES

Corporate Head Office

www.arb.com.au

42-44 Garden St
Kilsyth, Victoria
AUSTRALIA 3137

Australian enquiries
North & South American enquiries
Other international enquiries



Tel: +61 (3) 9761 6622
Fax: +61 (3) 9761 6807

sales@arb.com.au
sales@arbusa.com
exports@arb.com.au

REQUIRED TOOLS FOR FITMENT OF PRODUCT:

4mm Hex Key	Soft Mallet/Hammer
-------------	--------------------

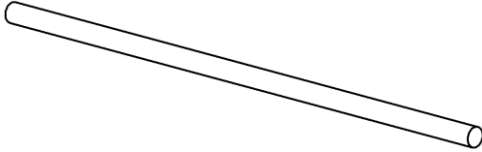
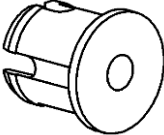
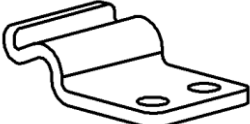
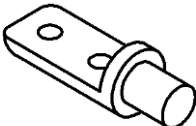
PARTS LISTING

APPLICATION.	PART NO.	QTY	DESCRIPTION
	-	1	TUBE ROLLER
	3163252	2	END CAP ROLLER
	3752670	4	BRKT ROLLER MOUNT
	4765012	2	SHAFT ROLLER
	6151256	4	SCREW M6X16 SS
	4581304	4	WASHER M6 SS

FITTING PROCEDURE

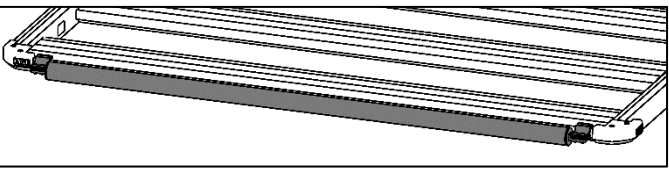
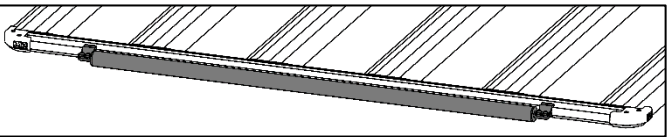
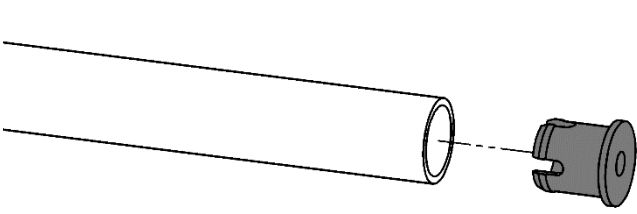
	<p>1. Choose mount location, the roller can be fitted anywhere on the outside perimeter, without a guard rail fitted</p>
	
	<p>2. Press in roller caps on both ends of the tube. A soft mallet/hammer may be required to fully seat</p>

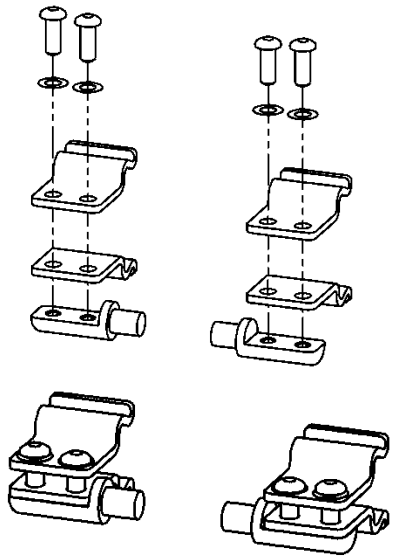
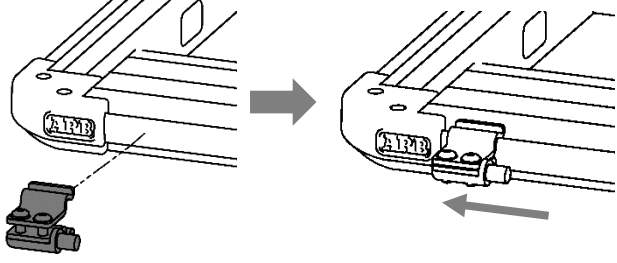
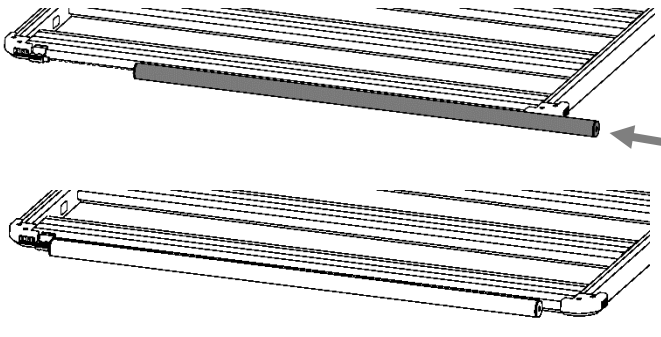
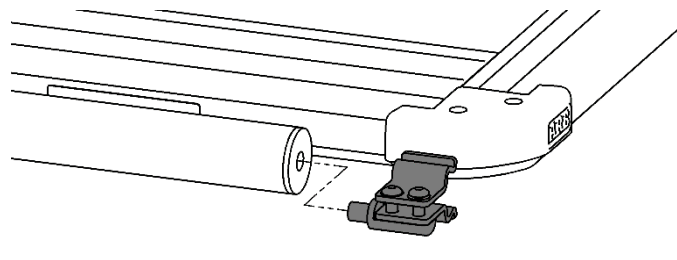
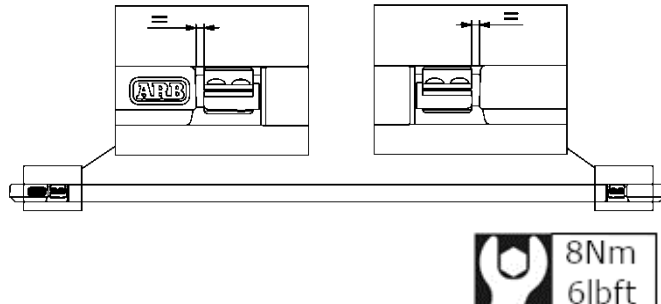
	<p>3. Fasten a pair of mount brackets and roller shafts using 2xM6 screws and washers</p> <p>Note these should be assembled as opposite pairs</p> <p>Only insert the screws 2-3 turns</p>
	<p>4. Place one bracket assembly over the dovetail. The pin should face inwards.</p> <p>5. Loosely tighten and slide against end cap</p>
	<p>6. Slide the roller over the pin</p>
	<p>7. Slide the opposing bracket into the roller and over the dovetail</p> <p>8. Loosely tighten</p>
	<p>9. Centre the roller on the rack</p> <p>10. Tighten M6 bolts to specified torque</p> <p>11. Check roller spins freely</p> <p>Note: if roller is hard to turn, loosen bolts and make a small gap between the pin and end cap</p>

ARB BASE RACK