



# FITTING INSTRUCTIONS

Part Number: **3414630**

Product

Description: **HILUX SUMMIT BULLBAR**

Suited to

vehicle/s: **5/18ON SUITS HILUX ROGUE, SR, SR5**

Optional

Fitting Kits: **3500680 – FOG LAMP HOUSING CLEAR LENS KIT**

**3500720 - SUMMIT BAR WINCH INSTALL KIT**

**3500850 – RFL COVER**

## WARNING

### REGARDING VEHICLES EQUIPPED WITH SRS AIRBAG:

When installed in accordance with these instructions, the front protection bar does not affect operation of the SRS airbag.

### ALSO, NOTE THE FOLLOWING:

- ◆ This product must be installed exactly as per these instructions using only the hardware supplied.
- ◆ In the event of damage to any bull bar component, contact your nearest authorised ARB stockist. Repairs or modifications to the impact absorption system must not be attempted.
- ◆ Do not use this product for any vehicle make or model, other than those specified by ARB.
- ◆ Do not remove labels from this bull bar.
- ◆ This product or its fixing must not be modified in any way.
- ◆ The installation of this product may require the use of specialized tools and/or techniques
- ◆ It is recommended that this product is only installed by trained personnel
- ◆ These instructions are correct as at the publication date. ARB Corporation Ltd. cannot be held responsible for the impact of any changes subsequently made by the vehicle manufacturer
- ◆ During installation, it is the duty of the installer to check correct operation/clearances of all components
- ◆ Work safely at all times
- ◆ Unless otherwise instructed, tighten fasteners to specified torque

## **ARB 4x4 ACCESSORIES**

Corporate Head Office

42-44 Garden St  
Kilsyth, Victoria  
AUSTRALIA, 3137

Tel: +61 (3) 9761 6622  
Fax: +61 (3) 9761 6807

Australian enquiries  
North & South American enquiries  
Other international enquiries

sales@arb.com.au  
sales@arbusa.com  
exports@arb.com.au

**www.arb.com.au**

# GENERAL CARE AND MAINTENANCE

By choosing an ARB Bar, you have bought a product that is one of the most sought after 4WD products in the world. Your bar is a properly engineered, reliable, quality accessory that represents excellent value. To keep your bar in original condition it is important to care and maintain it following these recommendations:



- Prior to exposure to the weather your bar should be treated to a Carnauba based polish on all exposed surfaces. It is recommended that this is performed on a six monthly basis or following exposure to salt, mud, sand or other contaminants.
- As part of any Pre Trip Preparation, or on an annual basis, it is recommended that a thorough visual inspection of the bar is carried out, making sure that all bolts and other components are torqued to the correct specification. Also check that all wiring sheaths, connectors, and fittings are free of damage. Replace any components as necessary. This service can be performed by your local authorized ARB Stockist.

## FITTING REQUIREMENTS

### REQUIRED TOOLS FOR FITMENT OF PRODUCT:

BASIC TOOL KIT	ELECTRIC DRILL WITH COMPLETE METRIC DRILL SET
JIG SAW OR OSCILATING MULTITOOl WITH BLADE SUITABLE FOR PLASTIC	LOW TACK MASKING TAPE
FILE	UTILITY KNIFE
TAPE MEASURE	CLAMP
STEEL RULER	WHITE FELT MARKER
HACK SAW	TORQUE WRENCH
TOUCH UP PAINT ANTI CORROSION	RIGHT ANGLE ELECTRIC DRILL

### HAVE AVAILABLE THESE SAFETY ITEMS WHEN FITTING PRODUCT:

Protective eyewear		Hearing protection	
--------------------	---	--------------------	---

**NOTE:** „WARNING“ notes in the fitting procedure relate to OHS situations, where to avoid a potentially hazardous situation it is suggested that protective safety gear be worn or a safe work procedure be employed. If these notes and warnings are not heeded, injury may result.

### FASTENER TORQUE SETTINGS:

SIZE	Torque Nm	Torque lbft
M6	9Nm	7lbft
M8	22Nm	16lbft
M10	44Nm	32lbft
M12	77Nm	57lbft

## PARTS LISTING

APPLICATION.	PART NO.	QTY	DESCRIPTION
FIT MOUNTS TO CHASSIS	4654475R	1	MNT BRKT ASSY SUITS HILUX RHS
	4654475L	1	MNT BRKT ASSY SUITS HILUX LHS
	3759667R	1	BRKT CHASSIS OUT HILUX 15ON RH
	3759667L	1	BRKT CHASSIS OUT HILUX 15ON LH
	3759666R	1	BRKT CHASSIS IN HILUX 15ON RHS
	3759666L	1	BRKT CHASSIS IN HILUX 15ON LHS
	6151094	2	BOLT M12 x 1.25 x 30 Gd8.8 ZP
	6151428	4	NUT FLANGE M12 X 1.75 ZP
	4581007	14	WASHER FLAT ½ x 1 1/2 x 4MM SILVER TZP
	6151357	8	BOLT SEMS M10 X 30 ZP Gd8.8
	6151321	8	NUT FLANGE M10 x 1.5 ZP
	4581040	8	WASHER FLAT M10 X 25 X 3 ZP
	3194818	4	PLATE NUT ASSY HILUX BAR 15ON
	6151360	12	BOLT M12 x 1.75 x 35 Gd 8.8 ZP
FIT BAR TO MOUNTS	6151360	6	BOLT M12 x 1.75 x 35 Gd 8.8 ZP
	6151357	4	BOLT SEMS M10 X 30 ZP Gd 8.8
	4581007	6	WASHER FLAT ½ x 1 1/2 x 4MM SILVER TZP
	6151428	6	NUT FLANGE M12 X 1.75 ZP
	6151321	4	NUT FLANGE M10 x 1.5 ZP
FIT LIGHTS AND MOULDINGS	3500880	1	GRILLE SPLIT PAN KIT
	5100200	1	BUFF KIT 2PCE FRONT SECTION KIT
	5100210	1	BUFF KIT 2PCE REAR UPRIGHT BAR KIT
	6821287	1	LAMP LED INDICATOR CLEARANCE KIT
	3163197	1	SURROUND ARB FOGLIGHT KIT
	6821116	4	GROMMET NYLON SNAP IN TYPE
	6821298	2	HARNESS EXT 19W FOG LAMP
FIT STONE GUARDS	6523237	1	STONE PANEL SUITS HILUX
	6523236R	1	WING PANEL SUITS HILUX RHS
	6523236L	1	WING PANEL SUITS HILUX LHS
	6151300	8	NUT CAGED M6 2.6-3.5
	6151234	6	BOLT M8 x 1.25 x 25 Gd 8.8 BP
	4581082	10	WASHER FLAT, M6 x 19 x 1.6 BZ
	6151301	4	NUT CAGED M8
	4581307	6	WASHER FLAT, M8 x 20 x 2 BLK ZN
	6151213	10	BOLT M6x1.0x20 8.8 BZ
6151548	2	FLANGE NUT M8X1.25 BLK ZN	
FIT WINCH COVER PANEL	6522985	1	PRESS FORM WINCH COVER PANEL
	6151213	4	BOLT M6x1.0x20 8.8 BZ
	4584295	4	WASHER FLAT M6 X 12 X 1.3 BLK ZN
	6151128	4	NUT FLANGE M6 x 1.0 ZP
FIT LICENSE PLATE	3759488	1	BRACKET REG PLATE FIXED LARGE RAD
	6151384	2	SCREW ST PHD 5.2x16
	6821189	2	GROMMET RND FC 1500 080 090
	6151213	3	BOLT M6x1.0x20 8.8 BZ
	4584295	3	WASHER FLAT M6 x 12 x 1.3 BLK ZN
	6151128	3	NUT FLANGE M6 x 1.0 ZP
MISCELLANEOUS	6191030	1	PINCH WELD 520mm
	3789832	1	CUTTING TEMPLATE SUITS HILUX
	180302	8	CABLE TIE 4.8 x 180mm BLACK

## FITTING PROCEDURE



**Note: Read the instructions thoroughly before starting.**

1. Open the bonnet and remove all scrivenets (8) retaining plastic cover.  
Set aside scrivenets removed for re-use later on.

**Note: Take note where all fasteners are removed from as some have to be refitted later in the fitment.**



2. Remove plastic cover from above grille and set aside, this will be reused.



3. Remove upper grille retaining screws (4).  
Set aside for re-fitment later on.

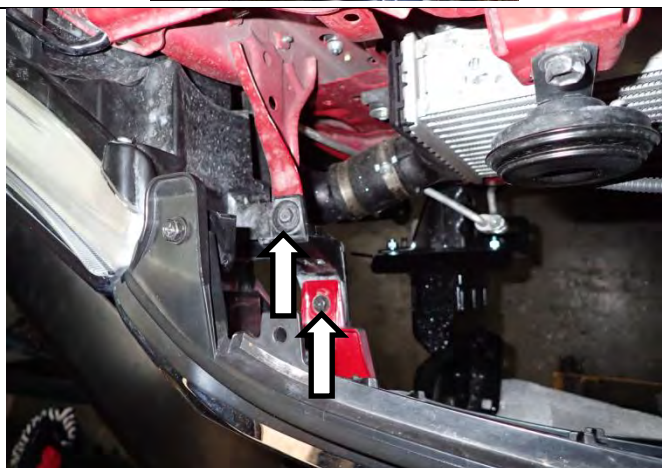

4. Remove lower grille retaining screws – (Right hand side shown).  
**Note: Centre grille retaining screw shown in lower image.**  
Set aside for re-fitment later on.





5. Remove all fasteners and scrivets retaining bumper along inside edge of wheel arches – (Right hand side shown).

Set aside for re-fitment later on.

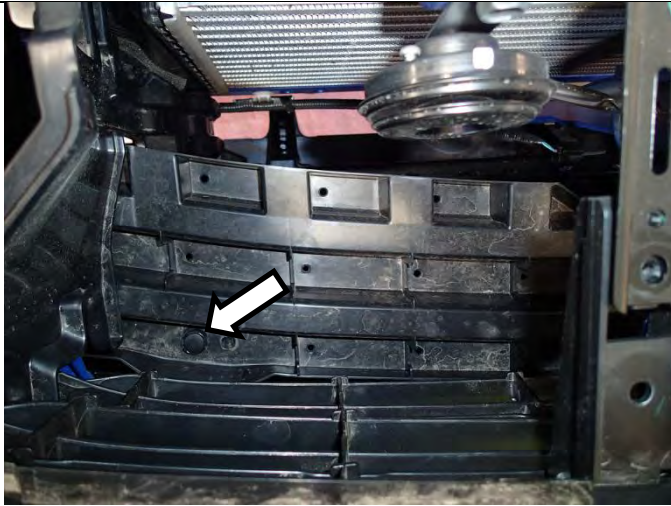

6. Remove the scrivets (2) used to fasten the lower grille tabs to the upper crush panel. (Right hand side shown).

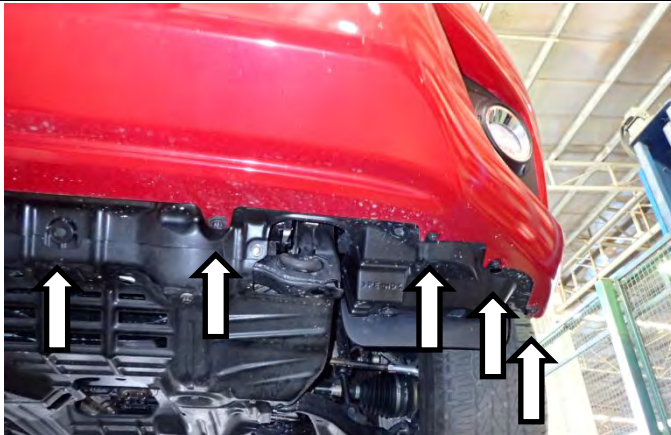

7. Remove all fasteners and scrivets retaining bumper along lower lip – (Left Hand side shown).

Set aside scrivets and fasteners used to attach bumper to OEM stone deflector for re-use later on.



8. Remove dressing piece from underside of bumper and discard.





9. If vehicle is equipped with adaptive cruise control, unplug radar (located behind Toyota badge)



10. Ensure inner guards are unclipped from front bumper.



11. Disconnect fog light wiring – (Right Hand side shown).



12. Remove registration plate and set aside, then carefully remove bumper from vehicle by pulling on each side of the bumper near the wheel arches and working your way towards the centre.

Set grille and bumper aside for re-use later in the fitment procedure.



13. If fitted, remove fog lights from bumper and set aside for reuse in bull bar.



14. Remove plastic lower crush absorber from vehicle and discard.

**Note: Lower crush absorber is retained by plastic clips. Levering absorber free with a large screw driver may aid removal.**



15. Remove 2 x M10 bolts on both sides (4 total) fixing crash beam to chassis and remove crash beam.

Discard crash beam.

**Note: Retain 4 x M10 bolts for re-use.**

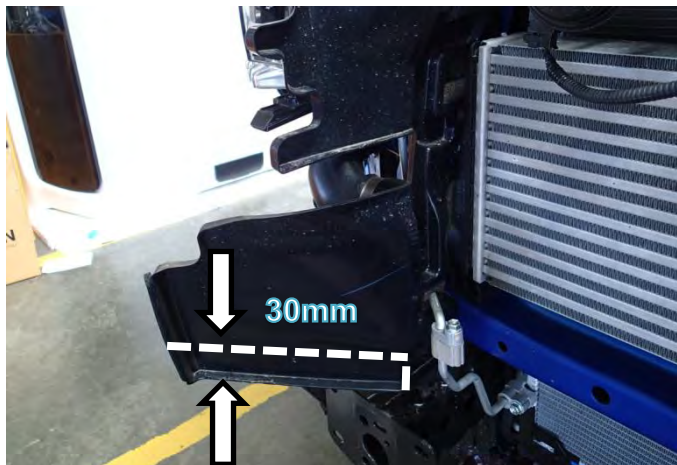

16. Locate air deflector panels and mark up 30mm from bottom edge as detailed in the image – (Right Hand side shown).

17. Use an oscillating multitool or shears to carefully cut lower portion away and discard.

**Note: Take care not to damage any other components on the vehicle whilst cutting.**

18. Carefully remove any burrs or sharp edges with a file and/or sandpaper.







19. With grille and bumper removed, remove LH and RH headlight retaining fasteners to allow headlight to be moved forward giving access to indicator/headlight wiring.

Note: Retain all fasteners for re-use later in the fitment procedure.

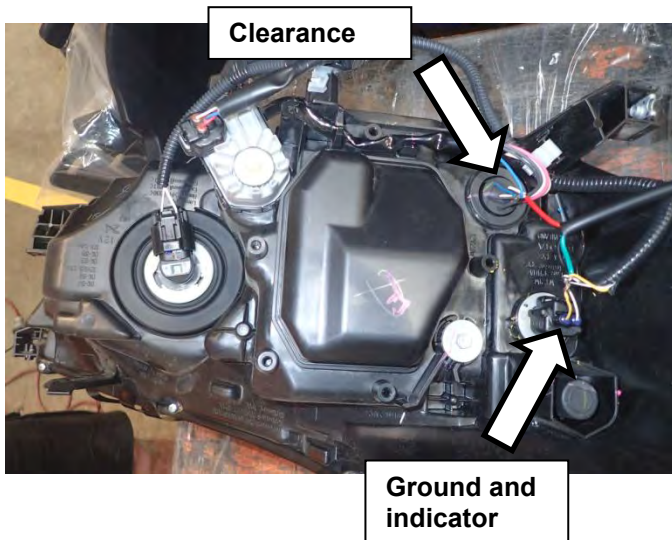

20. Following fitting instructions 3789197 supplied in kit 6821287; attach the LED combination lamp looms (also supplied in same kit). Vehicle coloured wires can be found in the positions indicated.

**Notes:**

- Use a test light or multimeter to pick the appropriate wire to attach the loom to.
- Use solder to connect the joints.
- Cover each joint with either insulation tape or heat shrink tube.
- Use cable ties to secure all wiring.

Function	LED Wire	Vehicle Wire
Ground	Black	Black (RHS & LHS)
Indicator	Green	Red (RHS) Yellow (LHS)
Clearance	Red	Larger white (RHS & LHS)





21. Re-install LH and RH headlights using original fasteners.

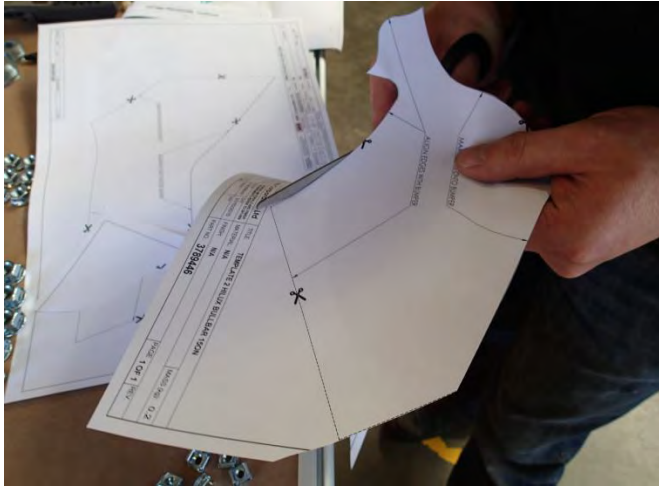

22. Carefully cut out bumper cut template supplied.

**Note: Template will be used for both sides (LH & RH) – be careful not to damage.**



23. Stick masking tape onto bumper at area underneath headlight as shown running the tape well in towards the centre of the bumper.

24. Position template onto RHS of bumper aligning with edges of bumper specified on template.

25. Using a permanent marker, outline edges of bumper cut template onto masking tape where the bumper cut will be performed.

Remove template and repeat for LHS. Take care not to rip template upon removal.

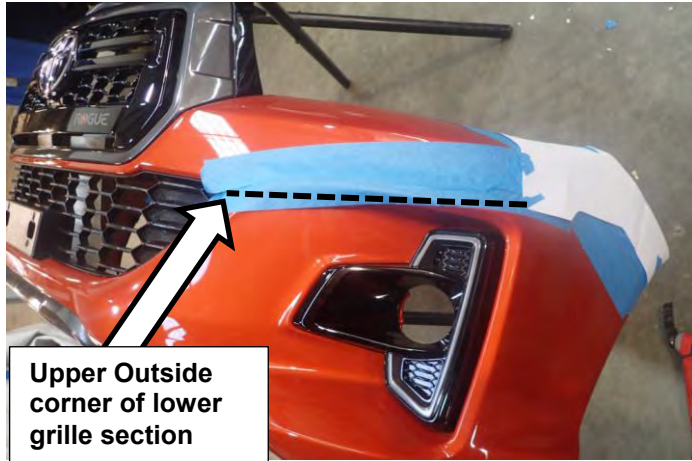

Upper Outside corner of lower grille section

26. Apply a generous amount of masking tape in the area indicated on the bumper.
27. Using a ruler draw a continuous straight line from the edge of the cutting template to the upper outside corner of the lower grille section.  
**Note: A steel rule or tape measure can be used as a guide for marking out.**
28. Repeat above for LHS.



Unclip from upper section of bumper

DISCARD LOWER SECTION SHOWN

29. Carefully cut bumper along marked lines using an oscilattng multitool or jig saw.
30. Repeat for LHS.
31. Unclip lower grille section from upper bumper and grille.
32. Discard lower grille and bumper section, this will not be reused



**Warning: Drilling operations can result in flying metal debris, safety glasses should be worn.**



33. Re-install trimmed bumper and grille using OE fasteners removed in previous steps.  
  
Ensure both scrivets are fitted inside wheel arches on each side.



34. If vehicle is equipped with adaptive cruise control, reconnect radar.





35. Fit Pinch weld to RH side along the full length of the cut edge. Carefully trim off any excess length and use remainder for other side.

**Note: 1 full length of pinch weld supplied, 1/2 used on each side of vehicle.**

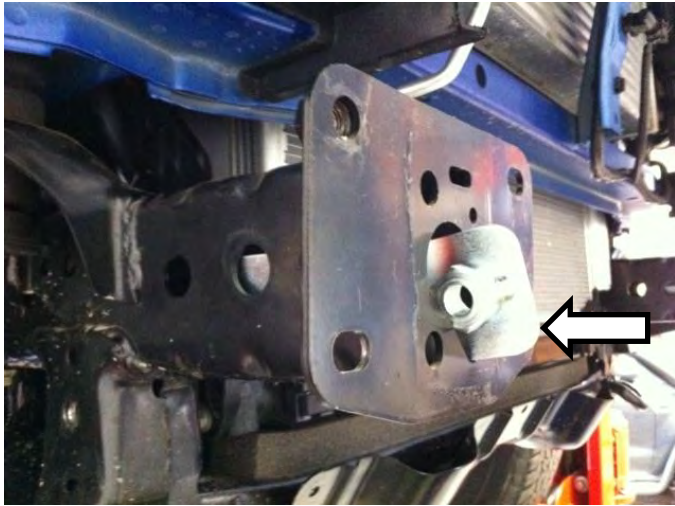

36. Insert 2 x M12x1.75 nut plate into RHS chassis rail as shown.

**Note: 1 x nut plate is used to fasten the outer chassis support to the outside face of the chassis and 1 x nut plate is to fasten the inner chassis support to the inner face of the chassis. Install nut plates accordingly.**

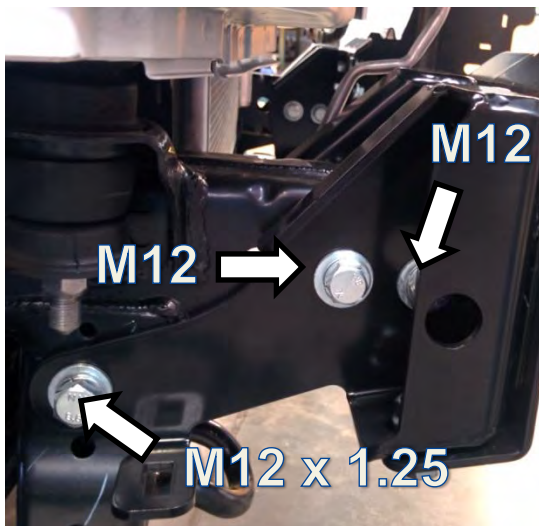

37. Loosely fasten RHS outer chassis support bracket to outside face of chassis using 2x M12x1.75x35mm bolts, and flat washers installed into the previously installed nut plate.

38. Loosely fasten the RHS outer chassis support bracket at the rear hole using M12 x 1.25 x 30 bolt and flat washer installed into OE captive nut in the chassis bracing.



**NOTE: IF USING A LARGE SIZE SOCKET, IT MAY BE NECESSARY TO PLACE THE SOCKET OVER THE FRONT BOLT BEFORE INSERTING AN EXTENSION THROUGH THE HOLE IN THE FLANGE.**



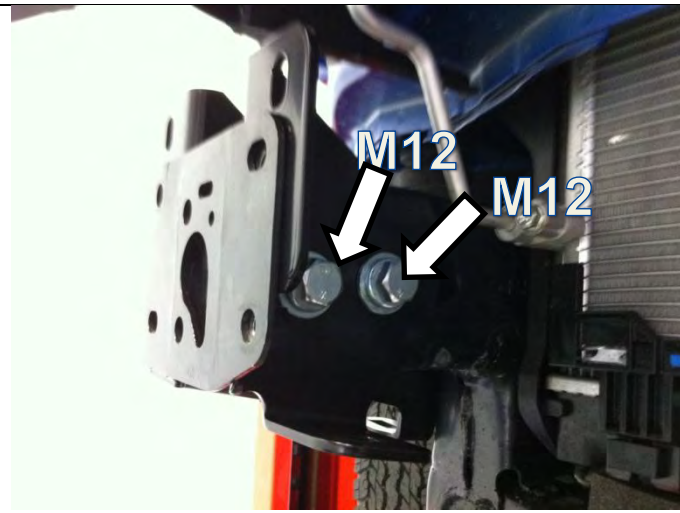

39. Loosely fasten RHS inner chassis support bracket to inside chassis face using 2x M12x1.75x35mm bolts and flat washers installed through the holes into the previously installed nut plate.
40. Repeat process to install chassis support brackets on LHS.



41. On both RH And LH installation it is extremely important that 1 x M10 x 25 x 3mm flat washer per hole is installed on the upper holes between the support brackets and the mount when offering the mount up to the chassis flange. The upper M10 bolts as installed in step below should pass through the mount, spacer washers and the support brackets.

(RH Outside support shown below).



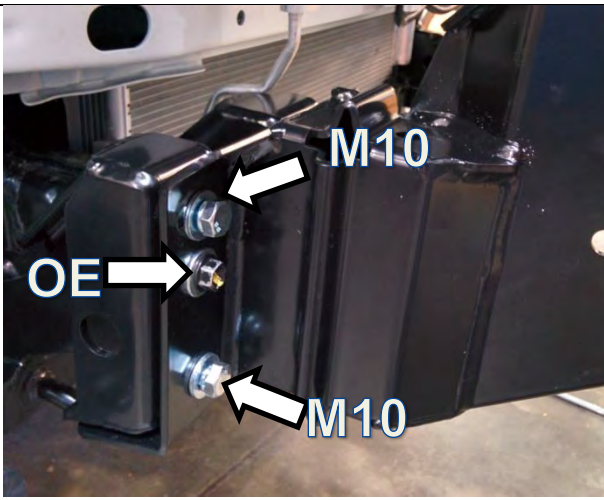

42. Loosely install RHS Bullbar Mount onto chassis flange.  
-Install M10x25x3 washers onto 2 x OE M10 bolts (retained at step 15) and re-install into the chassis flange captive nuts (positions as indicated).
43. Ensure 2 x M10x25x3 washers are installed between chassis support bracket and mount plate (as detailed in step 41).
44. Loosely install 4 x M10 x 30 SEMS bolts and 4 x M10 flange nuts through mount, flange and chassis support brackets.

**NOTE: MOUNTS ARE HANDED. RIPPLES ARE ON THE OUTSIDE OF MOUNTS**

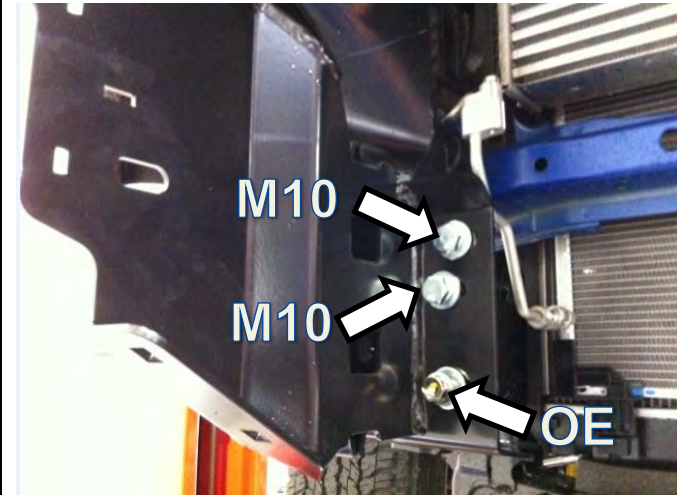
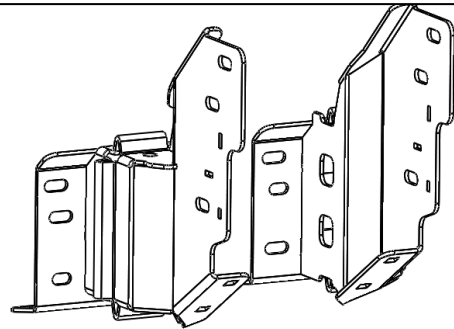

45. Loosely install 2 x M12 x 35 bolts and flat washers through lower mount and chassis support brackets into M12 flange nuts.

**Note: Starting with the M10 bolts installed from the front of the mount, tighten all fasteners enough to eliminate any play in mount or support brackets but to still allow for adjustment of bullbar.**

46. Repeat process to install Bullbar mount on LHS.

**NOTE: Check clearance between mount and AC line is approximately 15mm. If necessary the AC tube can be carefully bent away from the bracket by pushing the top section towards the vehicle. While bending the tube. Make sure you support the lower fittings to avoid damage.**

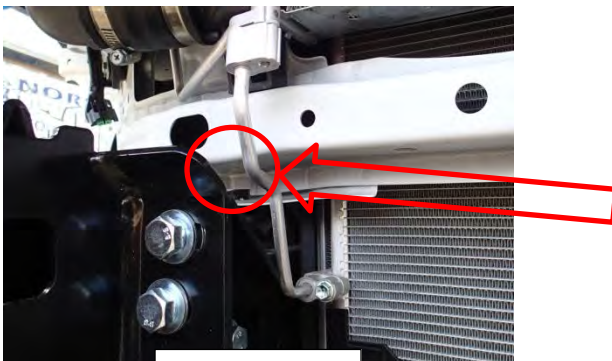
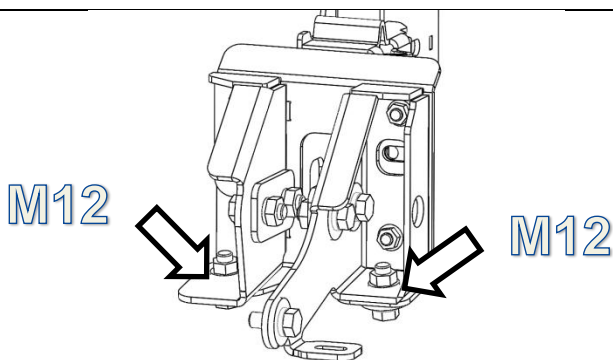

**Note: If fitting a winch proceed from here using fitting instructions 3789337 supplied with 3500720 winch install kit. Once the winch is fitted please continue to step 50. If no winch is being fitted continue from here.**

47. Slide the winch cover panel from the bottom up until it is level with the top face of the bar.

48. Fit the winch cover panel to the bar using 4 x M6 x 20 hex bolts, flat washers and flange nuts.

**Warning: Be careful not to scratch the finish of the winch cover panel.**

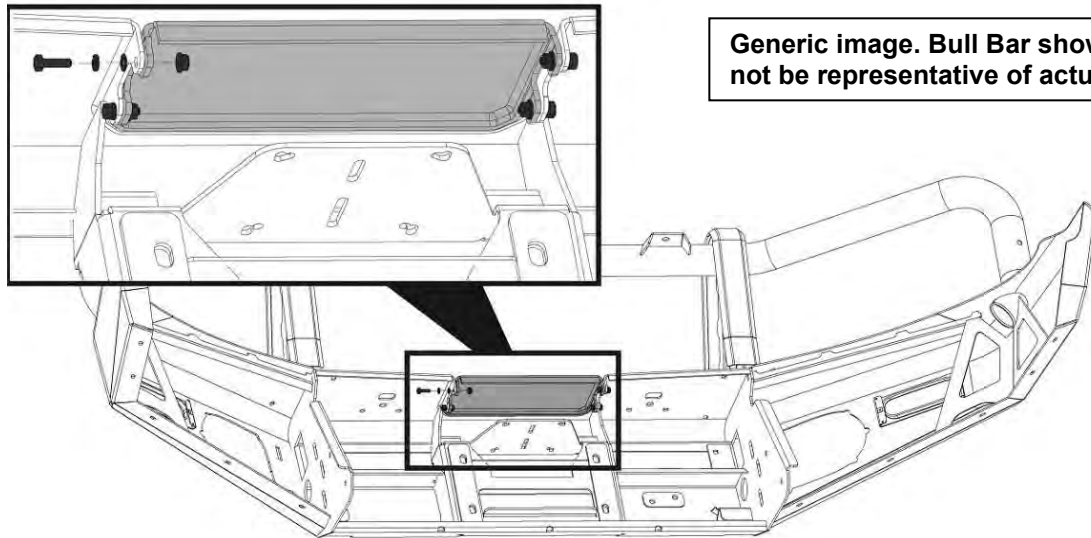

49. Fit the number plate bracket to the top face of the lower-centre pan on the bar using 3 x M6 x 20 hex bolts, flat washers and flange nuts.

**Note: If you are fitting a winch, fit the folding number plate bracket supplied in winch install kit "3500720 WINCH INSTALL KIT" – See fitting instructions 3789337**

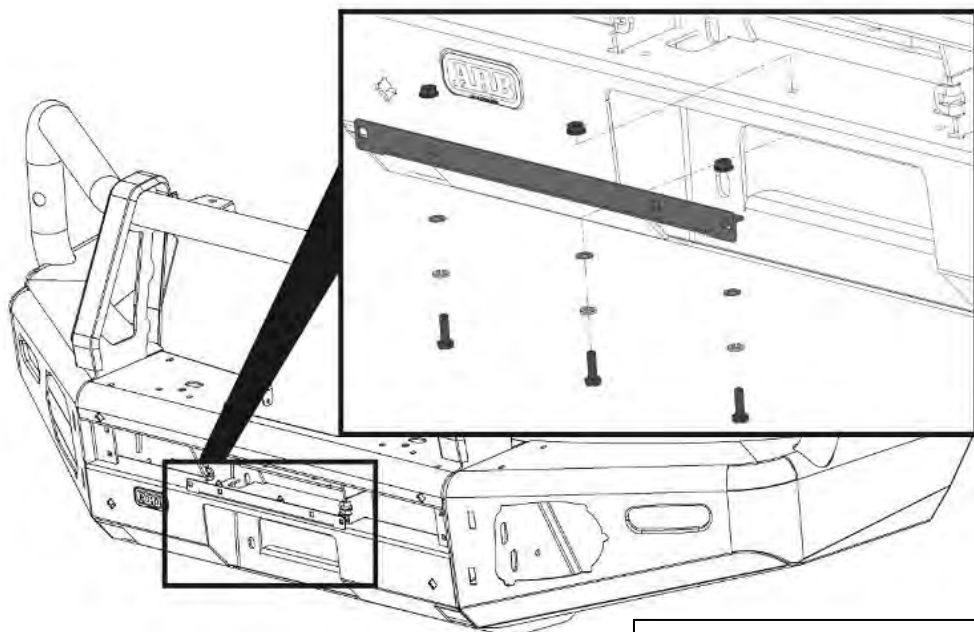

**Note: The following steps show the fitment of the plastic moulded parts. The mouldings are supplied in kits along with all fasteners required for fitment. It is important that the fasteners supplied with each kit are only used for the mouldings from the same kit.**



**The kits included in this bar kit are as follows:**

50. Layout the contents of each of the following kits ensuring the contents are kept separate from each other.

Kit No.	Description
5100200	BUFF KIT 2PCE FRONT SECTION
5100210	BUFF KIT 2PCE REAR UPRIGHT BAR
3500880	SPLIT PAN MESH KIT
3163082	FOG SURROUND KIT

51. Mark the grille panel to be cut at the 840mm marks at each end on the back face.

**Note: When marked, double check the measurement with a measuring tool.**

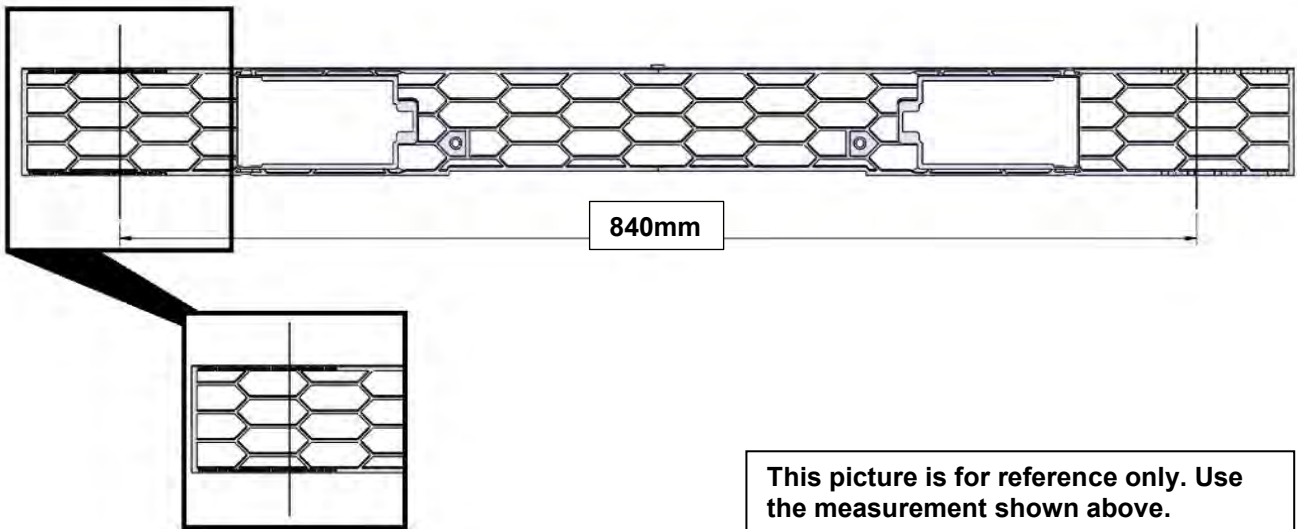

52. Use a hacksaw or similar cutting tool to carefully cut the grille panel at the positions marked in the step above.

53. Discard the off cuts and clean up the cut edges using a file or sandpaper.

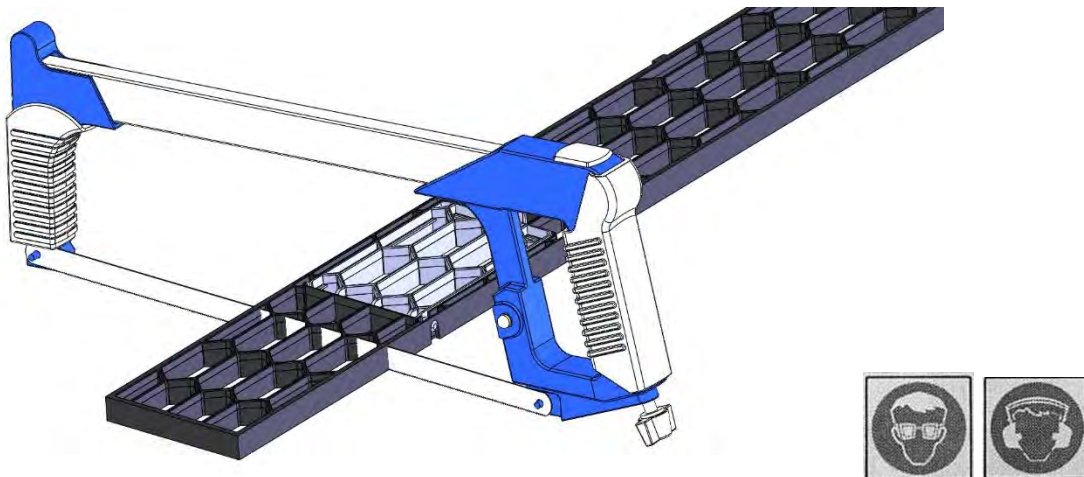

54. Insert the 6 x plastic grommets into the 6 square holes in the front face of the bar.

55. Insert the grille into the bar so that the hatches open outward (facing the front of the bar).

56. Attach the grille to the centre of the bar using the short screws into the grommets fitted above.

57. Attach the ends of the grille to the bar using the longer screws, through the clamp plates into the remaining grommets.

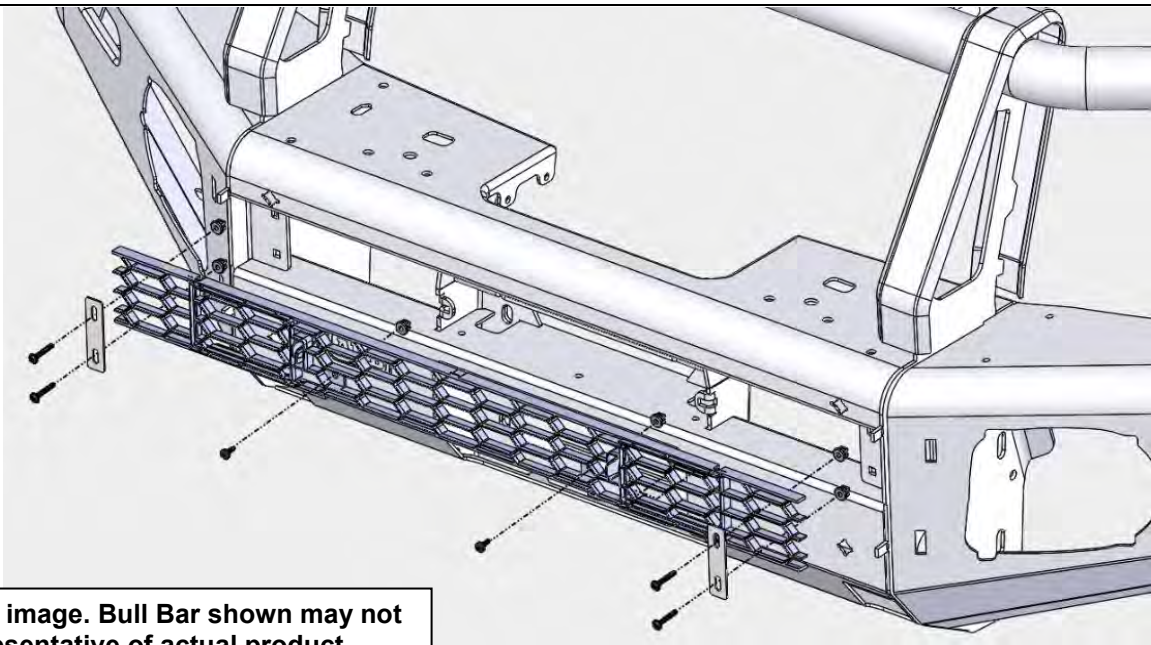

Generic image. Bull Bar shown may not be representative of actual product.

58. Fit the rubber intersection mouldings to the base of each upright cover strap.

Generic image. Bull Bar shown may not be representative of actual product.

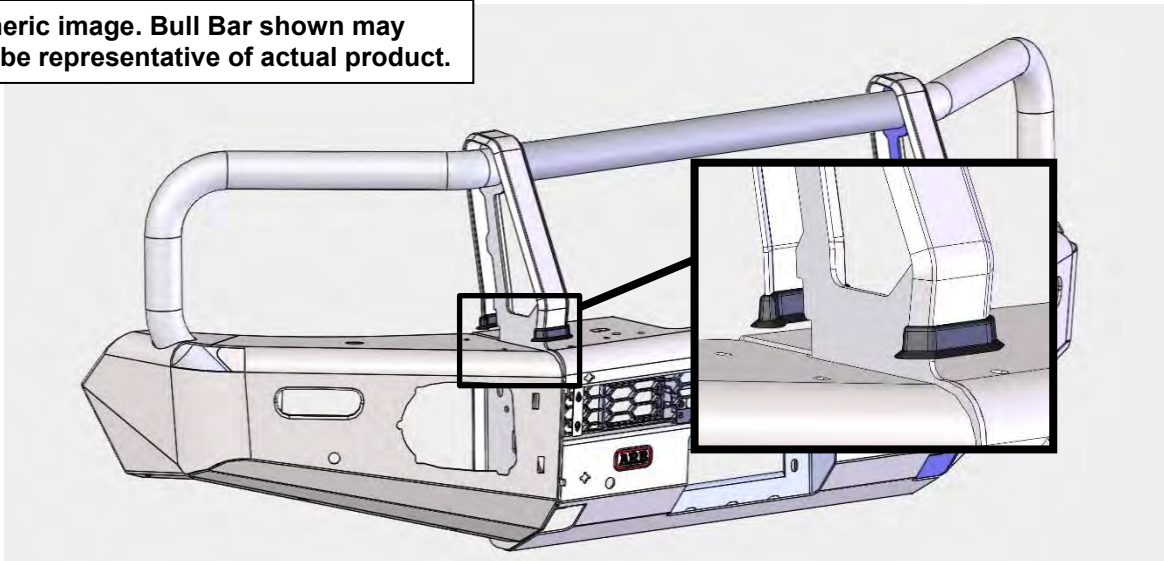

59. From the rear of the bar, slide the rear buffer sections under the rubber mouldings.

Fit 4 x screws and washers. Do not tighten screws. Leave enough play in buffers for adjustment later.

**Note: Ensure that the skirts of the rubber intersection mouldings are not folded back on themselves and are sitting flat against the buffers.**

Generic image. Bull Bar shown may not be representative of actual product.

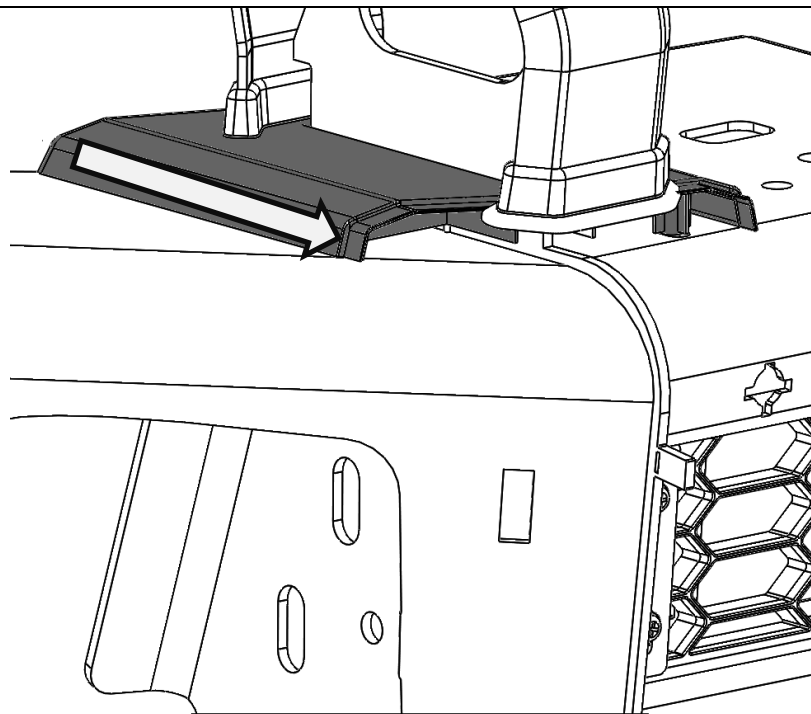

Fit washers under screw heads

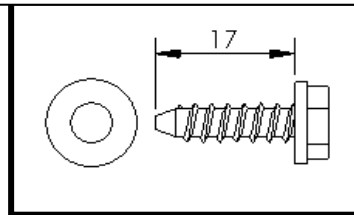



60. By aligning the front buffer with the tongue of the rear buffer, attach the front buffers to the front face of the bar. Ensure each buffer sits flat against the face of bar and is keyed into the top section of the rear buffer.

Secure wing side using retaining clips.

Secure inner side using the angled cup washers, flat washers and screws.

**The widest point of the cup washers goes to the top of the bar.**

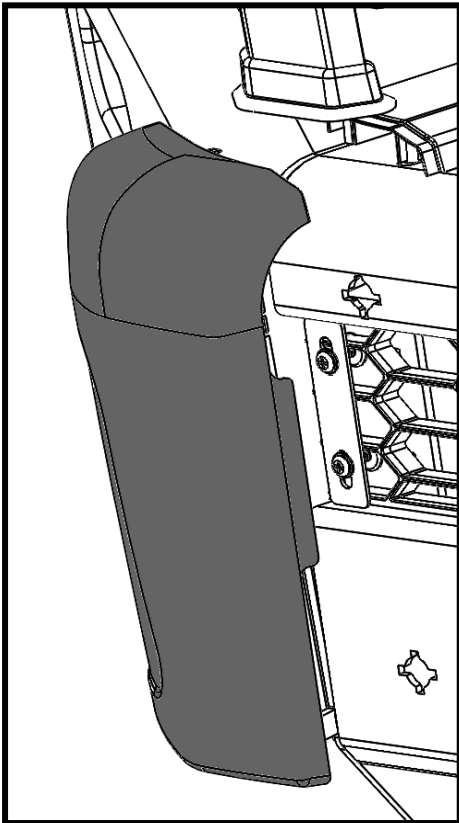

Generic image.  
Bull Bar shown  
may not be  
representative of  
actual product.

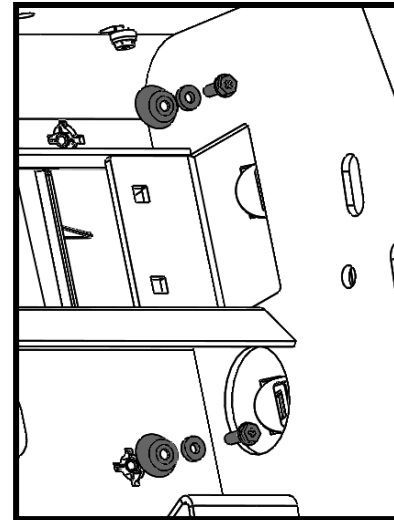

Fit washers under screw heads.

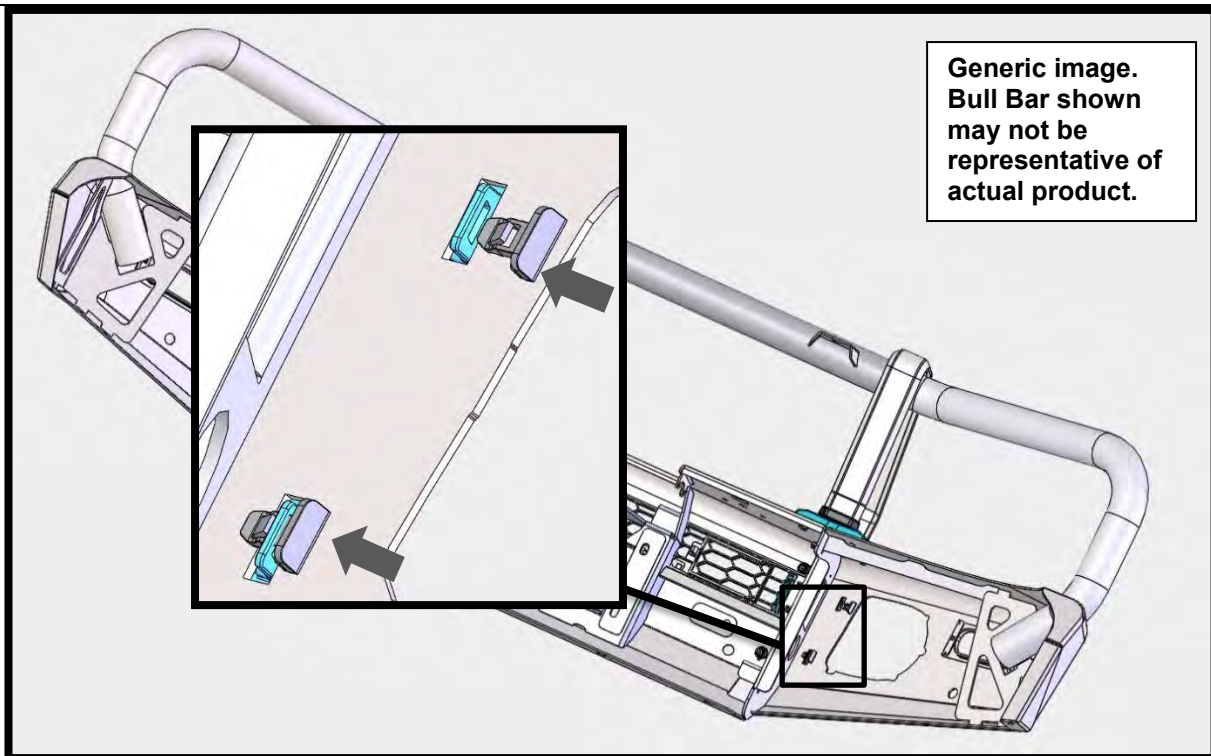
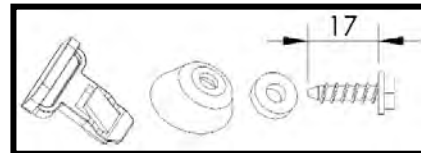

Generic image.  
Bull Bar shown  
may not be  
representative of  
actual product.

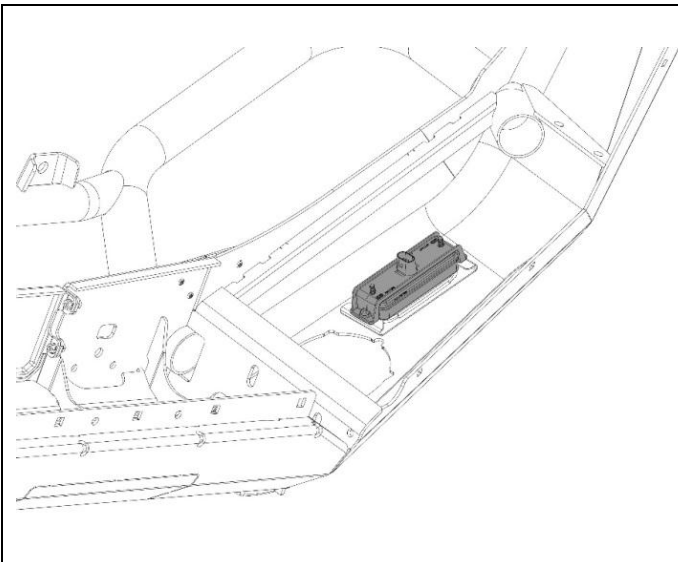

61. Fit the small square plastic grommets to the bar and attach the combination LED lamps to the bar using the screws provided with the lamp kit.



62. Ensure all other aftermarket accessories such as driving lights/winch/UHF aerial have been fitted to the bull bar.

**NOTE: If fitting a winch, Roller Fairlead must be drilled to 25mm offset if not already done so (see instruction #3789337).**

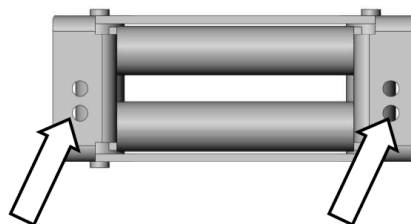

63. With the aid of a lift table or one or more assistants carefully and safely lift then position and loosely bolt the bull bar to the mounts using 6 x M12 bolts, large flat washers and M12 flange nuts. Centralise the bar to the front of the vehicle.

**NOTE: DO NOT DO UP TIGHT**



64. Loosely fasten bar to mounts using 6 x M12 x 1.75x35mm bolts, 6 x M12 flat washers (4mm thick) and 6 X M12 flange nuts.



65. Adjust position of bar left/right until it's sitting central to body, then tighten all fasteners joining mount assembly to chassis brackets (4x M10 and 2x M10 OE bolts each side).

 M10 – 44Nm

66. Tighten all inner and outer M12 chassis support bracket fasteners.

 M12 – 77Nm



67. Position the bar so that it is level with the bumper cut profile as shown and there is an even gap of 15-20mm between the wing edge and bumper cut trim.

68. Once bar is visually in correct position, tighten 6 x M12 fasteners joining bull bar to mount assembly.

 M12 – 77Nm







69. Drill 4 x Ø10mm holes (2 per side) through mount assembly using existing holes in bull bar as guide.
70. Add anti-corrosion touch up paint to area drilled.
71. Fasten 4x M10 SEMS bolts and flange nuts to pinning holes.



M10 – 44Nm



**Warning: Drilling operations can result in flying metal debris, safety glasses should be worn.**

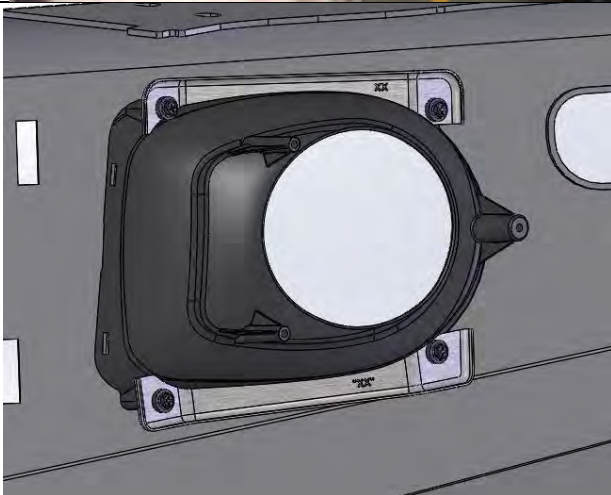

72. Install Fog light surrounds (3163197) as per instruction no. 3789800 supplied with surround kit into aperture of bull bar.

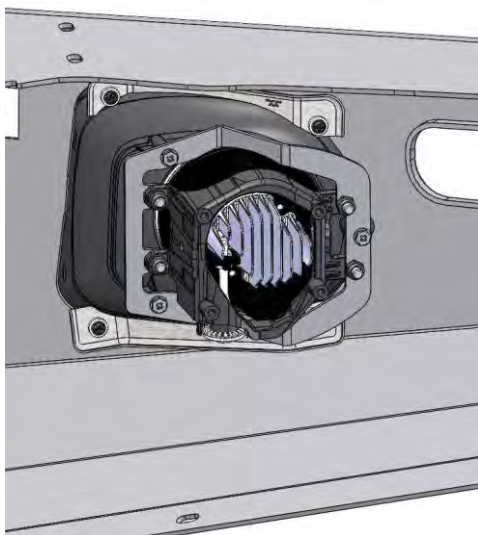

73. Assemble fog lights into surrounds as per instruction no. 3789800 supplied with surround kit 3163197.

**Notes: Optional clear covers (3500680) can now be fitted to the housings using fitting instruction no. 3789191.**



74. Using extension harnesses supplied, connect fog lights to vehicle loom.



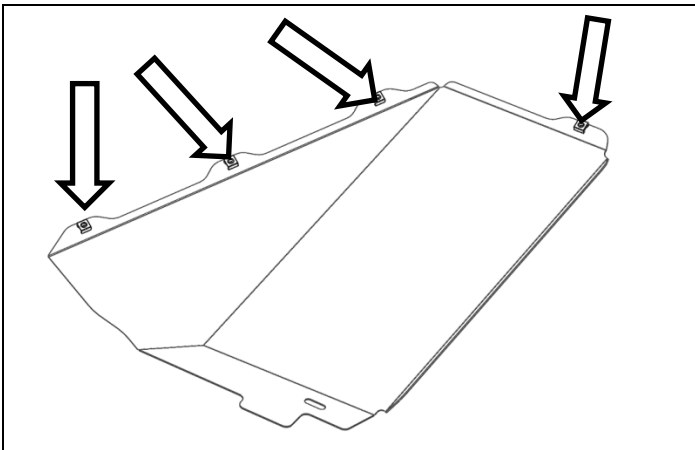

75. Fit 4 x M6 cage nuts to each wing under panel.

**Note: Cage nut heads to be located on top side.**

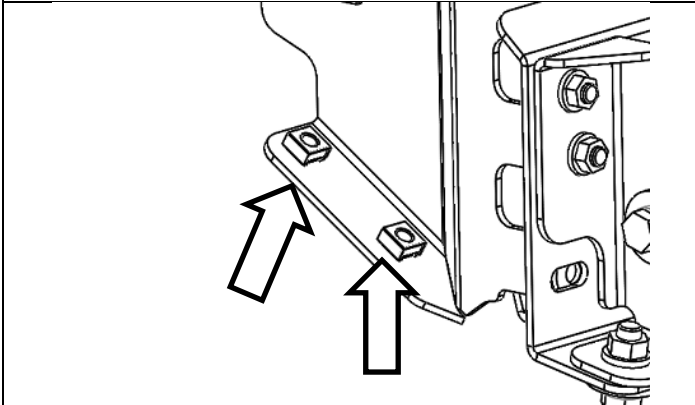

76. Fit 4x M8 cage nuts to RH and LH bull bar mounts as indicated. (RH Mount Shown)

**Note: Cage nut heads to be located on top side of bull bar lip and mount assembly.**

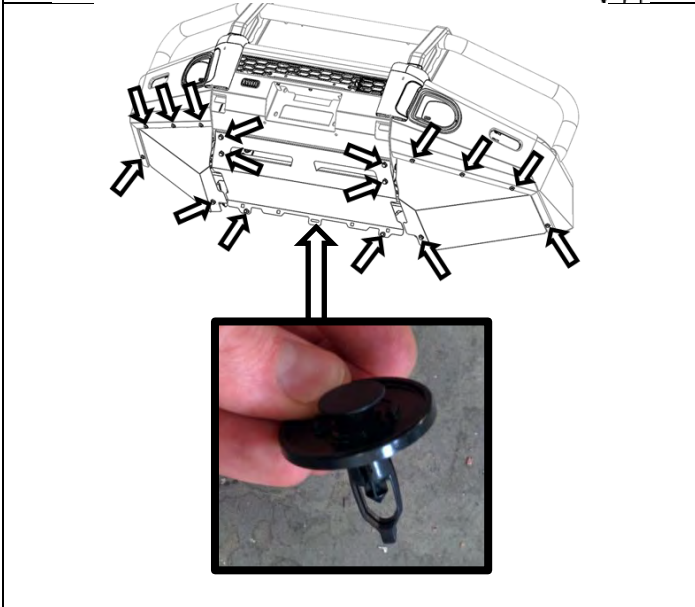

77. Fasten stone tray using 4x M8 bolts, flat washers and 2x M6 OEM fasteners

Fasten wing under panels to bull bar using 8 x M6 bolts & 8 x M6 flat washers.

Fasten lower corner of wing under panel using 2 x M8x1.25x25mm bolts, M8 flat washers and M8 flange nuts

Fasten centre hole of stone guard using OEM clip shown.

 M6 – 9Nm  M8 – 22Nm



78. Mark lines onto the OEM inner guards (LH & RH) using lower edge of wing under panels as guide ensuring enough guard remains so that it may be neatly tucked/secured behind wing under panel lip.

**Caution: Use care not to damage the windscreen washer bottle or hoses when trimming LH inner guard.**

79. Carefully cut along marked lines using jig-saw or shears.



**Warning: Drilling operations can result in flying metal debris, safety glasses should be worn.**



80. In line with the bottom edge of the lower bumper trim and the top edge of the bulbar wing tip use a pair of shears to cut a section approximately 20mm x 20mm from the inner guard outer edge to allow it to be pushed into the end of the wing. (RH Shown).

81. Push inner guard panel inside the end of the wing and behind the rear lip of the wing underpanels.







82. Re-install upper radiator cover panel and fasten using 8 x OE scrivenets.

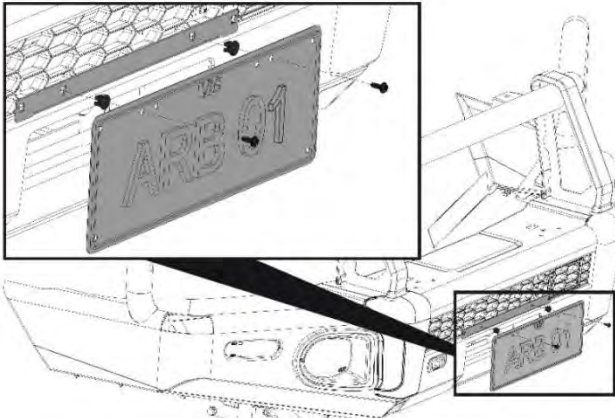

83. Fit the plastic plugs into the square holes in the registration plate bracket. Fit the registration plate to the bull bar using the black self-tapping screws.

84. Discard all remaining fasteners.

### FITTED PRODUCT – TOYOTA HILUX Summit bull bar

#### NOTICE: ONCE SUMMIT BAR IS FITTED:

- ◆ Ensure all bolts are tensioned correctly.
- ◆ All wiring is clear of sharp edges or moving surfaces and secured properly.
- ◆ Piping is secured well away from sharp or moving components.
- ◆ Check operation of winch, if fitted.
- ◆ Check all wiring and connections to turn signal lamps and clearance lights and that they are functioning correctly.

