



FITTING INSTRUCTIONS

Part Number: **3440400**
Product **DELUXE WINCH BULL BAR**
Description:
Suited to **FORD RANGER PX 2011-2015**
vehicle/s: **FORD RANGER PX2 2015ON**
Winch Install **3540050**
Kit:

WARNING

REGARDING VEHICLES EQUIPPED WITH SRS AIRBAG:

When installed in accordance with these instructions, the front protection bar does not affect operation of the SRS airbag.

ALSO, NOTE THE FOLLOWING:

- ◆ This product must be installed exactly as per these instructions using only the hardware supplied.
- ◆ In the event of damage to any bull bar component, contact your nearest authorised ARB stockist. Repairs or modifications to the impact absorption system must not be attempted.
- ◆ Do not use this product for any vehicle make or model, other than those specified by ARB.
- ◆ Do not remove labels from this bull bar.
- ◆ This product or its fixing must not be modified in any way.
- ◆ The installation of this product may require the use of specialized tools and/or techniques
- ◆ It is recommended that this product is only installed by trained personnel
- ◆ These instructions are correct as at the publication date. ARB Corporation Ltd. cannot be held responsible for the impact of any changes subsequently made by the vehicle manufacturer
- ◆ During installation, it is the duty of the installer to check correct operation/clearances of all components
- ◆ Work safely at all times
- ◆ Unless otherwise instructed, tighten fasteners to specified torque

ARB 4x4 ACCESSORIES

Corporate Head Office

42-44 Garden St
Kilsyth, Victoria
AUSTRALIA 3137

Tel: +61 (3) 9761 6622
Fax: +61 (3) 9761 6807

Australian enquiries
North & South American enquiries
Other international enquiries

sales@arb.com.au
sales@arbusa.com
exports@arb.com.au

www.arb.com.au

GENERAL CARE AND MAINTENANCE

By choosing an ARB Bar, you have bought a product that is one of the most sought after 4WD products in the world. Your bar is a properly engineered, reliable, quality accessory that represents excellent value. To keep your bar in original condition it is important to care and maintain it following these recommendations:

- Prior to exposure to the weather your bar should be treated to a Carnauba based polish on all exposed surfaces. It is recommended that this is performed on a six monthly basis or following exposure to salt, mud, sand or other contaminants.
- As part of any Pre Trip Preparation, or on an annual basis, it is recommended that a thorough visual inspection of the bar is carried out, making sure that all bolts and other components are torqued to the correct specification. Also check that all wiring sheaths, connectors, and fittings are free of damage. Replace any components as necessary. This service can be performed by your local authorized ARB Stockist

Important electrical system information

The 2011 Ford Ranger uses an advanced wiring system allowing new chassis control systems to be used. Due to this, placing large amounts of additional load to the wiring harness may trigger faults in the ECU or cause permanent damage to the wiring harness.



To prevent overloading the turn and clearance lights must be activated through relays. Relay looms are provided within this kit to wire these lights. For further reference please see the attached wiring diagram at the end of these instructions.

FITTING REQUIREMENTS

REQUIRED TOOLS FOR FITMENT OF PRODUCT:

BASIC TOOL KIT	ELECTRIC DRILL & Ø2, Ø5.5, Ø7 & Ø10MM BITS
JIG SAW WITH BLADE SUITABLE FOR PLASTIC OR MULTI TOOL	MATTE BLACK SPRAY PAINT
FILE OR SAND PAPER	MASKING TAPE
BASIC MEASURING TOOLS	ELECTRICAL TAPE (BLACK)
CONVOLUTED TUBE (7MM & 12MM)	TORQUE WRENCH 9-77Nm

HAVE AVAILABLE THESE SAFETY ITEMS WHEN FITTING PRODUCT:

Protective eyewear		Hearing protection	
--------------------	---	--------------------	---

NOTE: 'WARNING' notes in the fitting procedure relate to OHS situations, where to avoid a potentially hazardous situation it is suggested that protective safety gear be worn or a safe work procedure be employed. If these notes and warnings are not heeded, injury may result.

FASTENER TORQUE SETTINGS:

SIZE	Torque Nm	Torque lbft
M6	9Nm	7lbft
M8	22Nm	16lbft
M10	44Nm	32lbft
M12	77Nm	57lbft

PARTS LISTING			
APPLICATION.	PART NO.	QTY	DESCRIPTION
PREPARE VEHICLE	3789424	1	CUTTING TEMPLATE BUMPER RANGER PX2 15ON
	3787985	1	CUTTING TEMPLATE BUMPER PX 11-15
	6151349	4	SELF TAPPING SCREW PHILLIPS HD
MOUNT TO VEHICLE	3758263	1	MOUNT ASSEMBLY
	3758265R	1	CHASSIS BRACE RH
	3758265L	1	CHASSIS BRACE LH
	3758956	1	OE STONE SHIELD BRACKET
	4581011	10	WASHER FLAT M12 x 27 x 4
	6151360	10	HEX BOLT M12 x 1.75 x 35 G8.8
	6151428	10	FLANGE NUT M12
	4581050	10	WASHER SPRING M12
	6151357	6	SEMS BOLT ASSY M10 X 30
	4721760	4	CRUSH TUBE
	6151485	4	HEX BOLT M10 x 1.5 x 80
	3194288	2	NUT PLATE
	4581083	4	WASHER FLAT M10 x 21 x 2
	6151321	2	FLANGE NUT M10
	4581048	4	SPRING WASHER M10
	6151234	3	HEX BOLT M8 x 25 BLACK
	4581047	3	WASHER FLAT M8 BLACK
6151132	3	FLANGE NUT M8	
4581045	3	SPRING WASHER M8 BLACK	
BUFFERS, INDICATORS AND FOG LIGHTS TO BAR	3162470R	1	BUFFER RH
	3162470L	1	BUFFER LH
	6821151R	1	INDICATOR RH
	6821151L	1	INDICATOR LH
	3163015	1	FOG LIGHT SURROUND KIT
	6151128	12	FLANGE NUTS M6
	6821272	1	LOOM INDICATOR/CLEARANCE
	6151143	3	TEK-SCREWS
BAR TO VEHICLE	3194293	2	CAGE NUT PLATE
	6151306	6	CAGE NUT M12
	6151360	6	HEX BOLT M12 x 1.75 x 35 G8.8
	4581050	6	WASHER SPRING M12
	4581007	6	WASHER FLAT 1/2" x 1.1/2" x 4mm
	6151357	4	SEMS BOLT ASSY M10 X 30
	6151321	4	FLANGE NUT M10

PARTS LISTING			
APPLICATION.	PART NO.	QTY	DESCRIPTION
UNDER PANELS TO BAR	6522838	1	STONE SHIELD CENTRE
	6522837R	1	UNDER WING PANEL RH
	6522837L	1	UNDER WING PANEL LH
	3758957	2	BRACKET WING PANEL
	6151301	7	CAGE NUT M8
	6151234	11	HEX BOLT M8 x 25 BLACK
	4581307	11	WASHER FLAT M8 BLACK
	4581045	11	SPRING WASHER M8 BLACK
	6151300	14	CAGE NUT M6
	6151213	14	BOLT M6 x 20 BLACK
	4581082	14	WASHER FLAT M6 BLACK
	4581287	14	SPRING WASHER M6 BLACK
	6151132	4	FLANGE NUT M8
NUMBER PLATE TO BAR (NO WINCH FITTED)	6821189	2	PLASTIC PLUGS
	6151384	2	SELF TAPPING SCREWS
WINCH COVER PANEL FITMENT (NO WINCH FITTED)	6522938	1	PANEL WINCH ACCESS COVER
	6191013	1	RUBBER EXTRUSION
	4581304	2	WASHER M6 SS
	6151128	2	NUT FLANGE M6
	6151256	2	SCREW BUTTON HEAD M6 X 16 SS
WINCH TO BAR	3540050	1	OPTIONAL WINCH INSTALL KIT
DIGITAL RADIO ANTENNA RELOCATION	6151464	2	SCREW BUTTON HEAD M8 x 1.25 x 25 BLK ZN
	4581047	2	SPRING WASHER M8 BLK ZN
	4581307	2	WASHER FLAT M8 BLK ZN
	6151548	2	NUT FLANGE M8 x 1.25

NOTE:

- **IF FITTING TO PX2 2015ON RANGER PLEASE FOLLOW VECHICLE PREPARATION INSTRUCTIONS FROM PAGES 5-14 THEN FROM PAGE 26, STEP 133 ONWARDS**
- **IF FITTING TO PX 2011-2015 RANGER PLEASE FOLLOW FROM PAGE 15 STEP 60 ONWARDS.**

FITTING PROCEDURE



Note: Read the instructions thoroughly before starting.
IF FITTING TO 2015on PX2 RANGER START HERE.

1. Open the bonnet and remove the screws and retaining clips used to retain the plastic cover above the grille.
Carefully detach plastic cover.



2. Remove the screws and retaining clips used to retain grille.
Carefully detach grille piece from vehicle.
Place screws and clips in a safe place.

Note: Take note where fasteners are removed from as some have to be replaced later in the fitment.

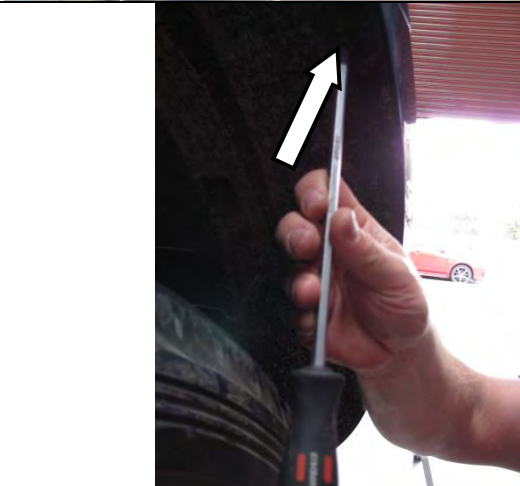

3. Remove all the bumper fasteners along the inside edge of the wheel arches.

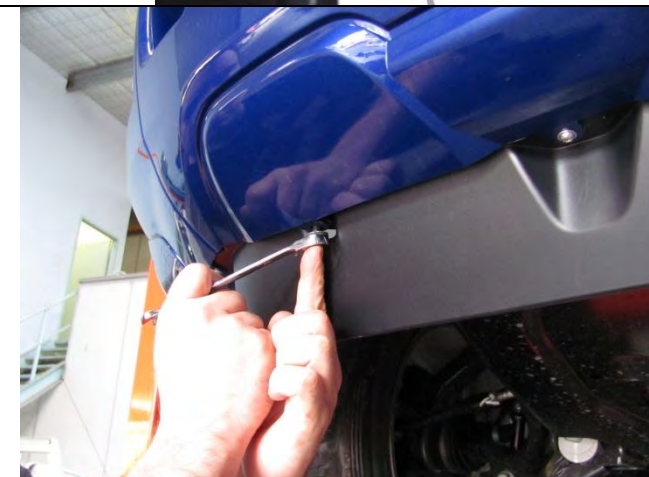

4. Remove all the fasteners securing the bottom of the bumper to the vehicle.

FITTING PROCEDURE

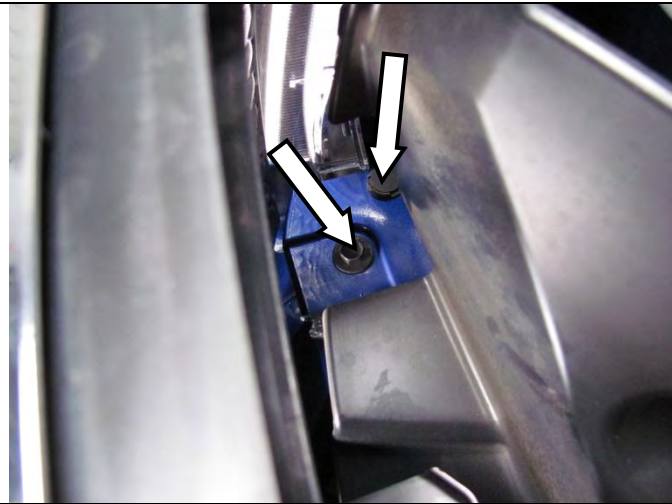

5. Undo and remove the screws and plastic clips behind the grille near the lower inner edge of the head lights.

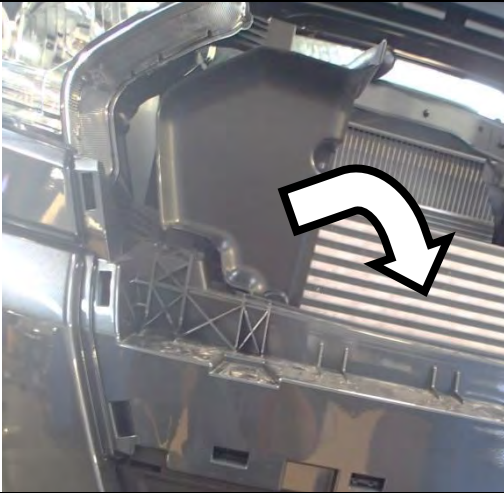

6. Remove the screws and clips holding the inner grille air deflectors to the vehicle.
7. Place air deflectors, screws and clips removed in a safe place.



8. Carefully remove all clips used to retain bumper to crash beam.

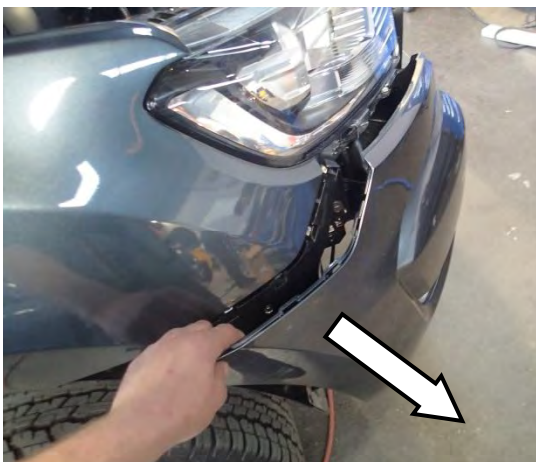

9. Starting on the RH side of the vehicle, carefully pull the rear most corner away from the vehicle un-clipping the bumper. With the assistance of another person remove the bumper from the vehicle and place in a safe place where it will not be damaged. Disconnect the sensor attached to the bumper and allow it to hang loose. If fog lights are fitted they will need to be disconnected.

FITTING PROCEDURE



10. Remove the plastic panel attached to the front cross beam by removing the plastic clips. Discard the panel.



11. Use a screw driver to push the 2 x plastic clips inward from the front cross beam. Do not remove the clips as they will be used later.



12. Remove the factory under panel and place in a safe place. ***Do not completely remove the rear bolts. Leave loose.***

FITTING PROCEDURE



13. Remove the front cross beam and discard.



14. Remove screws retaining RH & LH bumper retention blocks to vehicle and remove the retention blocks from both sides and set aside.



15. Remove and discard the inner guard support brackets from both sides of the vehicle.

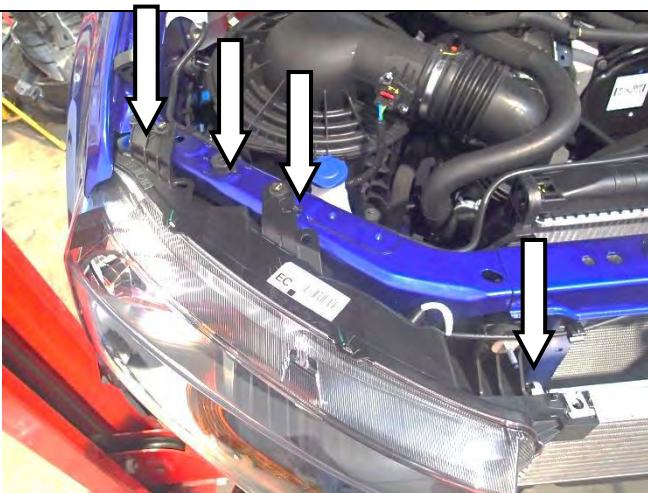

16. Starting on the RH side of the vehicle, remove the plastic clip, the 2 hex screws and the torx screw holding the headlight assembly in place and set aside.
17. Repeat on the LH side.

FITTING PROCEDURE



18. Carefully remove the head light assemblies from the vehicle, carefully unclipping the main head light globe plugs and completely removing both the turn light globes and left hand side clearance light globe.
19. Place the head light assemblies in a safe place where they will not be damaged.

20. Attach the combination indicator lamp looms (supplied in lamp kits 6821151R&L).

Notes:

- Use a test light or multi metre to pick the appropriate wire to attach the loom to.
- Use solder to connect the joints.
- Cover each joint with either insulation tape or heat shrink tube.
- Use cable ties to secure all wiring



21. Carefully mask the area surrounding each side of the guard as shown (RH shown, LH same).
22. Thoroughly clean the area.
23. Using Matte Black spray paint, paint the masked area.
24. Allow to dry.

Note: If you are fitting driving lights to the bar it is advisable that you install the wiring loom at this point.

FITTING PROCEDURE

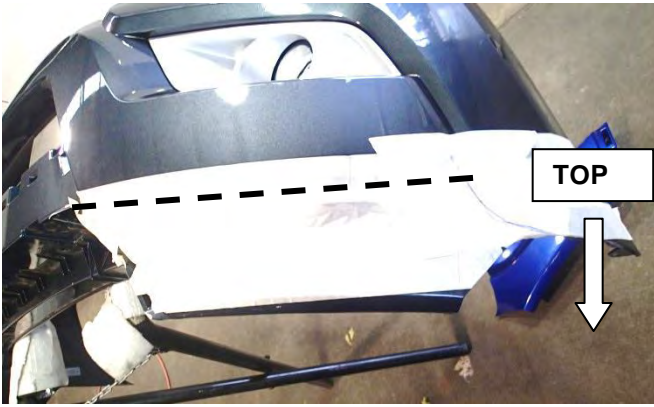

25. Place the bumper on a stand facing upwards.
26. Using masking tape, cover front corner section of bumper.
27. Using ridge on bumper as a guide, mark a line following the ridge across the front section of bumper as shown.

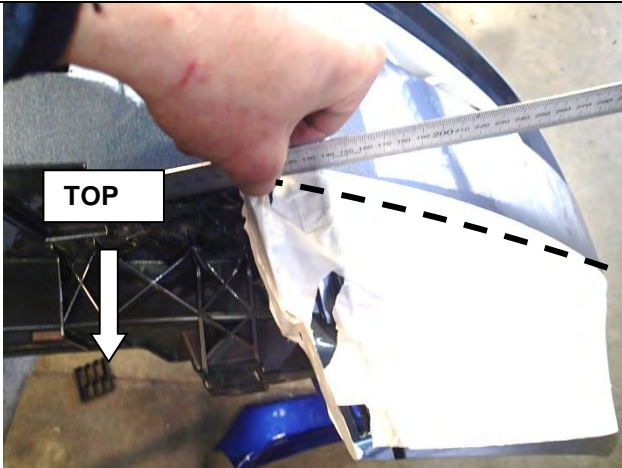

28. Continue the line onto the bumper as shown using the edge of bumper as a guide.
29. Mark a line perpendicular to bumper 30mm inwards from locating hole on top surface as shown until it meets line on bumper edge.

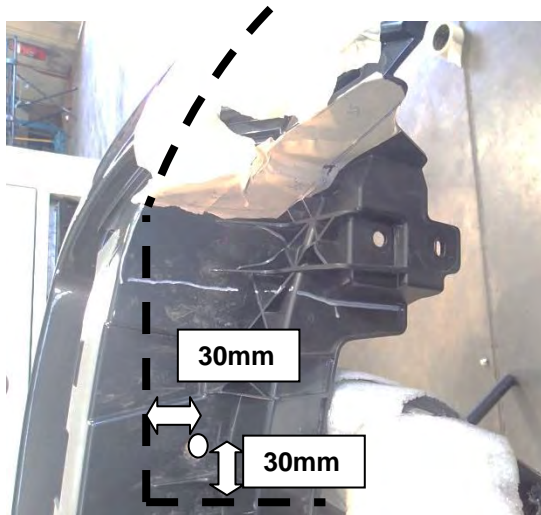

30. Using scissors carefully cut out the supplied template 3789424 for Ranger PX2.

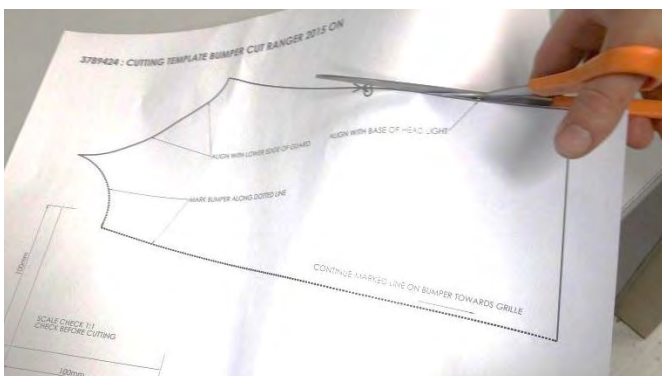

FITTING PROCEDURE

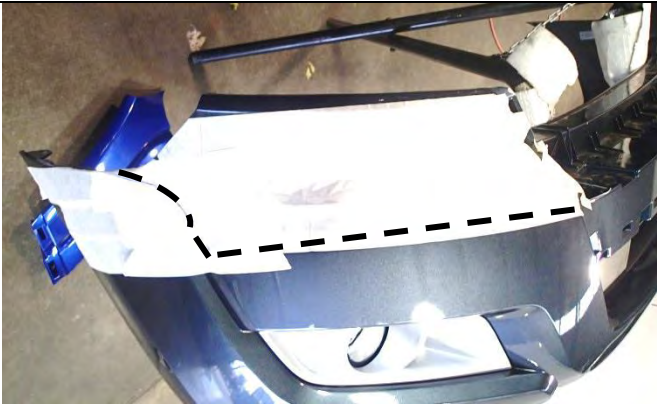

31. Position template onto bumper as shown and using a marker pen, mark contour onto bumper until it meets other line on bumper.
32. Carefully remove the template and repeat steps 27-32 for LHS.

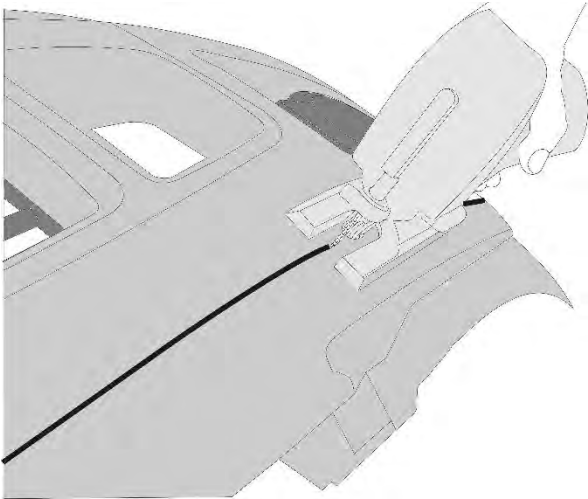

33. Using a jig saw or similar, carefully cut along marked lines.
34. De-bur the cut edges with a file or sandpaper.

Note: It is advised that you take steps to prevent damage to the bumper when cutting such as placing extra masking tape on the kept portion of the bumper.



35. Position cut bumper (RH) onto bumper retention block (RH) set aside and mark a line onto block as shown using a white marker pen.
36. Remove cut bumper and carefully cut along inside edge of marked line using a saw suitable for cutting plastic.
37. Repeat for LHS.
38. Use a file or sandpaper to de-bur all cut edges.
39. Set aside for re-fitment later on.



FITTING PROCEDURE

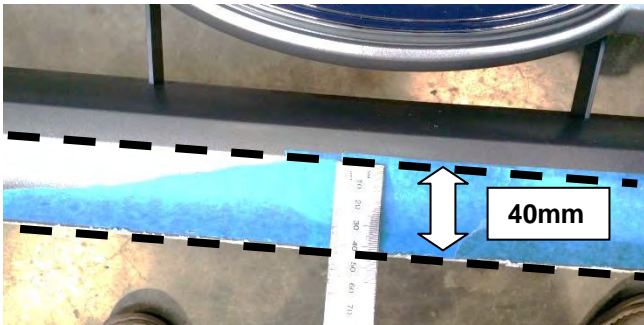

40. Place masking tape across front section of grille where ridge is as shown.
41. Mark line onto grille 40mm below ridge in grille as shown.
42. Using a jig saw or similar, carefully cut along marked line.
43. De-bur the cut edges with a file or sandpaper.
44. For chrome grille, position pinch weld supplied in kit along cut edge (centre the pinch weld across width of grille).



45. Fit two self-tapping screws into the lower section of the grille to join the two parts together as shown

FITTING PROCEDURE



46. Remove clips from digital aerial antenna and disconnect at connector.
47. Carefully cut around metallic plate corresponding to digital aerial antenna.
48. Place antenna in a safe place for re-locating later on. (Steps 165 -171)

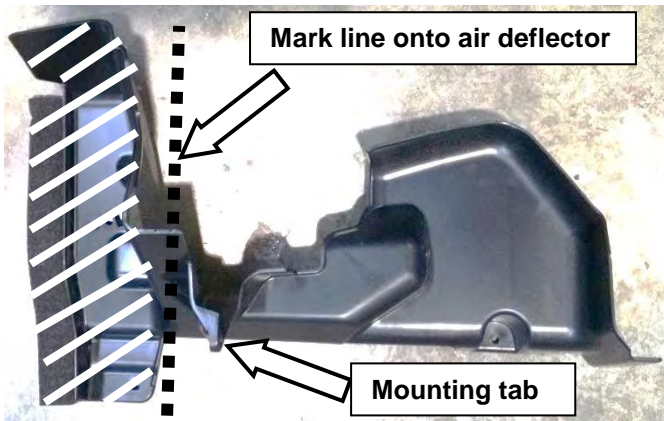

49. Mark a line onto RH air deflector removed in step 6 as shown 30mm below mounting tab.
50. Carefully cut along marked line and dispose of lower section of air deflector.
51. De-bur the cut edges with a file or sandpaper.
52. Repeat for LH air deflector.



FITTING PROCEDURE

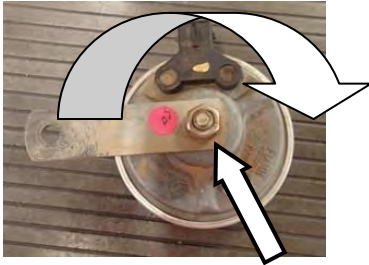

53. The horn & harness will require to be rotated for clearance to brackets. Unplug the harness and remove the horn by removing the mounting bolt.
54. Turn the horn over and loosen the retaining nut. Rotate the arm 180°, and tighten the retaining nut.
55. Re fit the horn in its original position and re-route the harness to the top. Use cable ties if necessary to reposition the harness.



56. Fit the bumper, grille and bumper retention blocks back onto vehicle using reverse sequence to removal process
57. Fit pinch weld to lower cut edge of grille
58. Drill an Ø2mm hole through each end corner of the bumper into the guard sheet metal.
59. Attach the bumper to the guards using the Phillips head self-tapping screws.



FITTING PROCEDURE



Note: IF FITTING TO 2011-2015 PX RANGER FOLLOW INSTRUCTIONS FROM HERE ONWARDS.

60. Open the bonnet and remove the plastic cover above the grille.

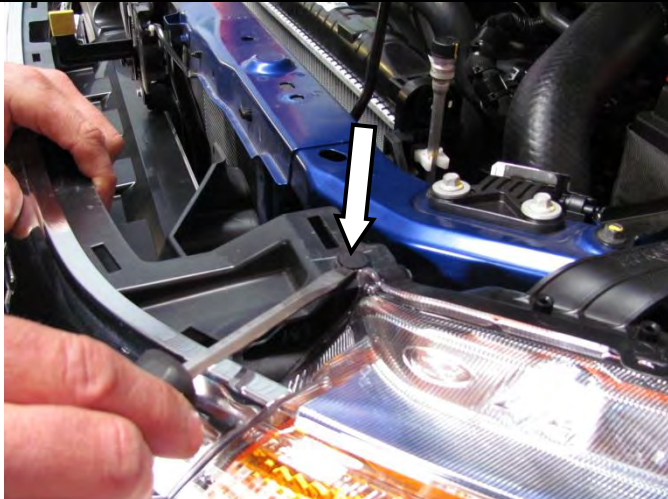

61. Remove the plastic clips from the top / rear corners of the grille. Place clips in a safe place.

Note: Take note where fasteners are removed from as some have to be replaced later in the fitment.

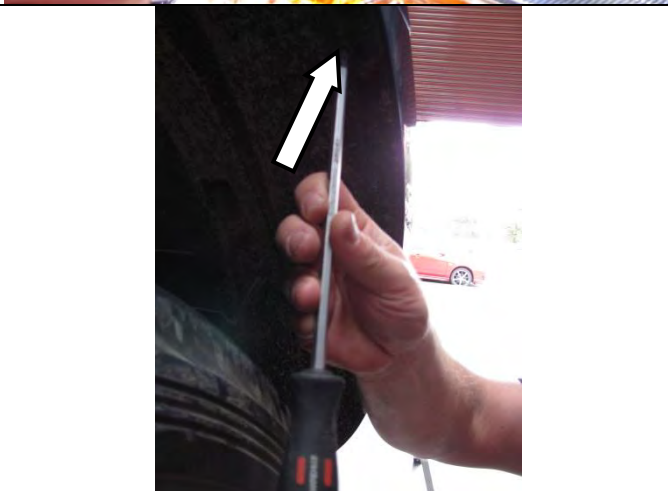

62. Remove all the bumper fasteners along the inside edge of the wheel arches.

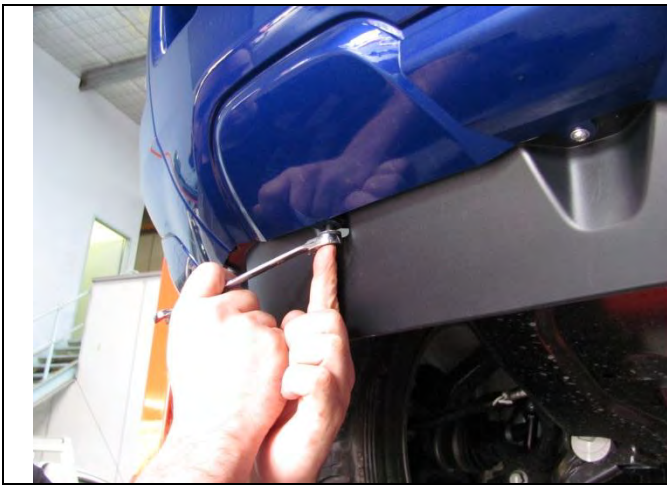

63. Remove all the fasteners securing the bottom of the bumper to the vehicle.

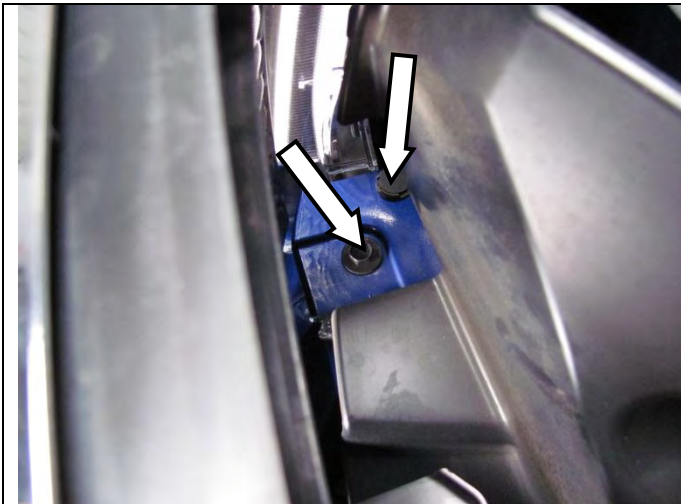

64. Undo and remove the screws and plastic clips behind the grille near the lower inner edge of the head lights.

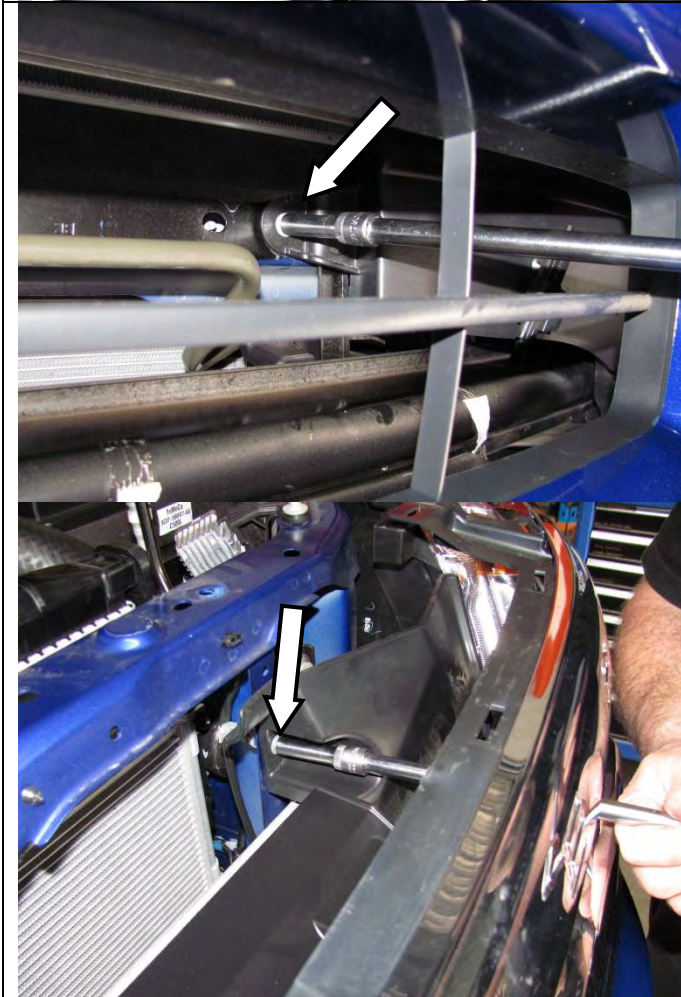

65. Using a socket extension, remove the screws holding the inner grille air deflectors to the vehicle. Place in a safe place.



66. Starting on the RH side of the vehicle, carefully pull the rear most corner away from the vehicle un-clipping the bumper. With the assistance of another person remove the bumper from the vehicle and place in a safe place where it will not be damaged. Disconnect the sensor attached to the bumper and allow it to hang loose. If fog lights are fitted they will need to be disconnected.



67. Remove the plastic panel attached to the front cross beam by removing the plastic clips. Discard the panel.



68. Use a screw driver to push the 2 plastic clips inward from the front cross beam. Do not remove the clips as they will be used later.

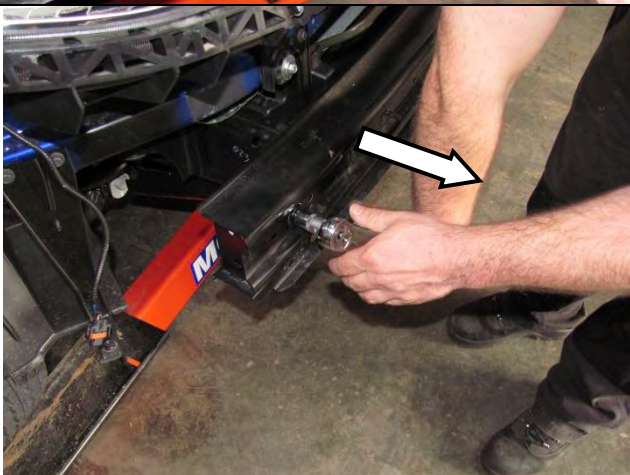

69. Remove the front cross beam and discard



70. Remove the factory under panel and place in a safe place. Do not completely remove the rear bolts. Leave loose.

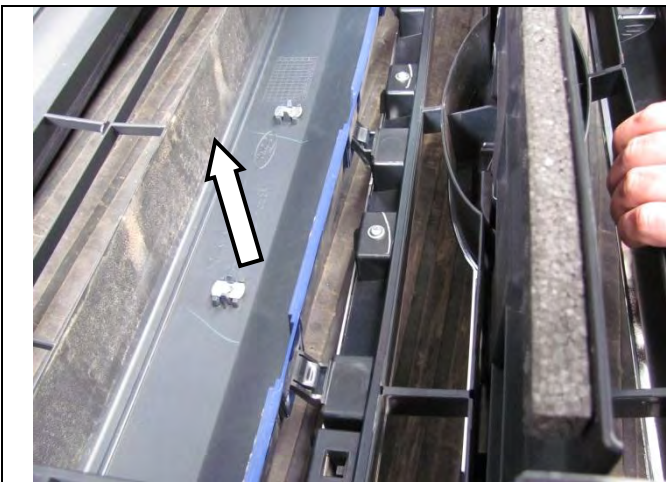

71. Carefully unclip the grille from the bumper and place in a safe place.



72. Remove the RH and LH bumper retention blocks from either side of the vehicle and place in a safe place.

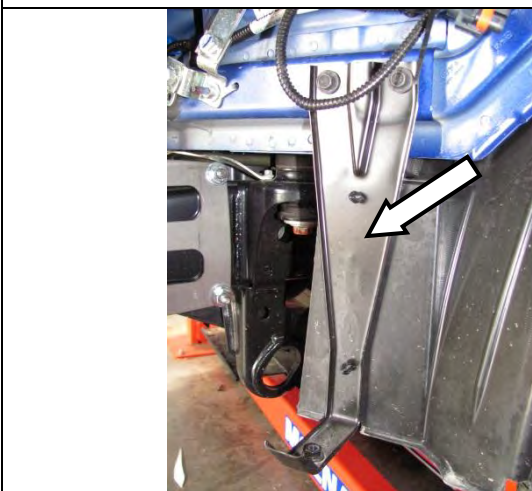

73. Remove and discard the inner guard support brackets from both sides of the vehicle.



74. Starting with the RH bumper retention block removed in step 73, mark as shown using a white marker pen. Note the position of the marking in relation to the lugs on the top edge of the block.



75. Use a saw suitable for cutting plastic and cut along the maker line.



76. Mark a line as shown parallel with the top edge in line with the tapered hole at the front of the block.

77. Mark a line from the end of the line marked in the previous step down to the bottom front corner of the block as shown.

78. Use a saw suitable for cutting plastic and cut along the marked line.

79. Use a file or sandpaper to de-bur all cut edges. The final part should like the one pictured.



80. Repeat steps 75-80 to mark and cut the LH block.

81. Set aside for later fitment.

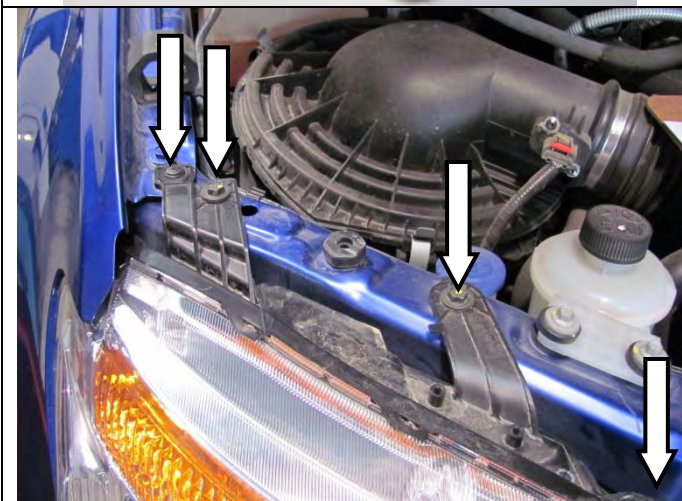

82. Starting on the RH side of the vehicle, remove the plastic clip, the 2 hex screws and the torx screw holding the headlight assembly in place and set aside.

83. Repeat on the LH side.



84. Carefully remove the head light assemblies from the vehicle, carefully unclipping the main head light globe plugs and completely removing both the turn tight globes and left hand side clearance light globe.
85. Place the head light assemblies in a safe place where they will not be damaged.

FITTING PROCEDURE

Refer to table below for Wire Colour designations of P/No: 6821272

LOOM INDICATOR / CLEARANCE	
DESCRIPTION	WIRE COLOUR
Main battery positive	Red
Main battery negative	Black
Clearance Light signal wire	Blue / Black
Left hand turn light signal wire	Green / Black
Right hand turn light signal wire	Yellow / Black



86. Using the tek-screws provided, attach the 3 relays to the panel directly behind the LH head light as shown.



87. Route the battery positive and the battery negative wires to the relevant sides of the vehicles battery. Do not attach at this stage.



88. On each side of the vehicle, carefully cut back the protective tubing from the turn light globes wiring being careful not to damage the wires inside.



89. On the left side of the vehicle, carefully cut back the protective tubing from the clearance light globe wiring being careful not to damage the wires inside.

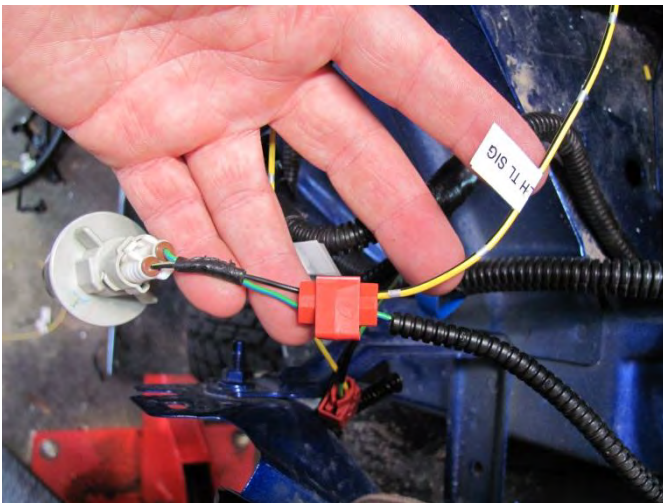

90. Starting on the LH side of the vehicle, scotch-lock the Clearance light signal wire of the loom (Blue / Black) to the OE positive clearance light wire (Green / Yellow).
91. Scotch-lock the Left Hand turn light signal wire of the loom (Green / Black) to the OE positive turn light wire (Green / Blue)
92. Cover the connections with black electrical tape for protection.

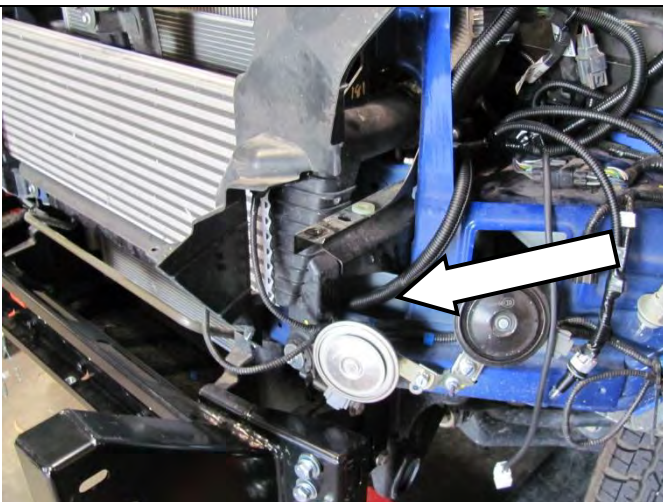

93. Route the remainder of the loom across the front of the vehicle along the cross beam that runs below the intercooler as shown.

Note: It is recommended that all wires are covered with protective convoluted tubing to prevent damage during use.

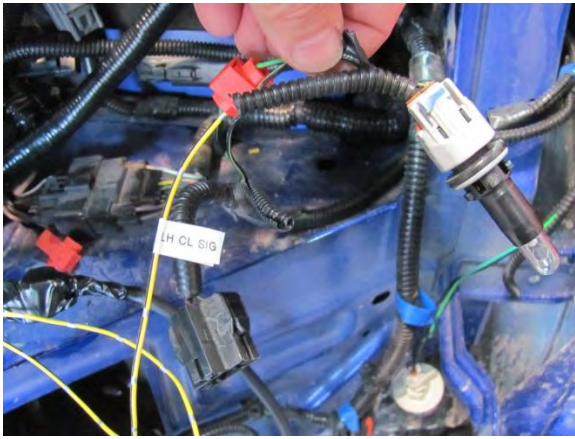

94. On the RH side of the vehicle, scotch-lock the Right Hand turn light signal wire (Yellow / Black) to the OE positive turn light wire (Blue / Yellow)
95. Cover the connections with black electrical tape for protection.

Note: A test light should be used to ensure that the correct wires are chosen.

FITTING PROCEDURE

Note: All wiring should be checked against the wiring diagram attached at the end of these instructions.

96. Tidy all wiring and secure neatly to the vehicle using the cable ties supplied with the indicator/clearance loom. Ensure they are kept away from sharp and moving parts.
97. Replace the head light assemblies by reversing the removal step above ensuring that the LH and RH White Connectors (to suit 6821151L/R) are able to hang down from below the head lights.
98. Connect the positive and negative battery wires to relevant terminals on the vehicles battery.



99. Carefully mask the area surrounding each side of the guard as shown (RH shown, LH same).
100. Thoroughly clean the area.
101. Using Matte Black spray paint, paint the masked area.
102. Allow to dry.
103. Re-fit the bumper retention blocks modified earlier.

Note: If you are fitting driving lights to the bar it is advisable that you install the wiring loom at this point.

FITTING PROCEDURE



104. Remove the 2 black plastic air deflectors attached to the bumper and set aside.
105. Place the bumper on a stand facing upwards.
106. Use masking tape to mark a straight line across the front of the bumper using the sharp corner at the front of the bar as a guide.

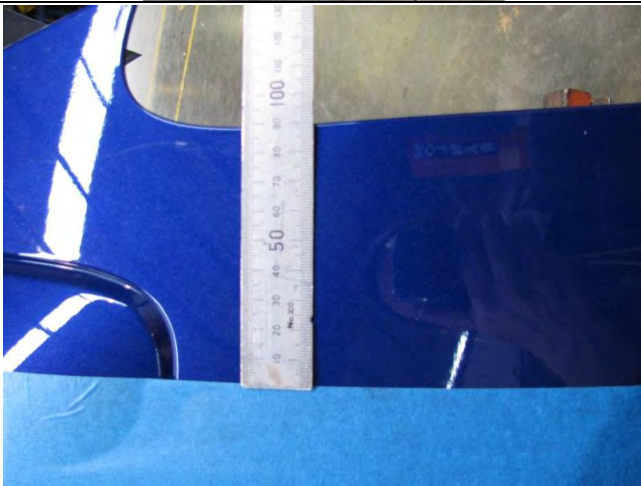

Note: The line should end up being 90mm below the edge of the bumper that mates with the vehicles guard.



107. Using a jig saw or similar, carefully cut along the line made in the previous step.

Note: It is advised that you take steps to prevent damage to the bumper when cutting such as placing masking tape on the jigsaw foot as shown.

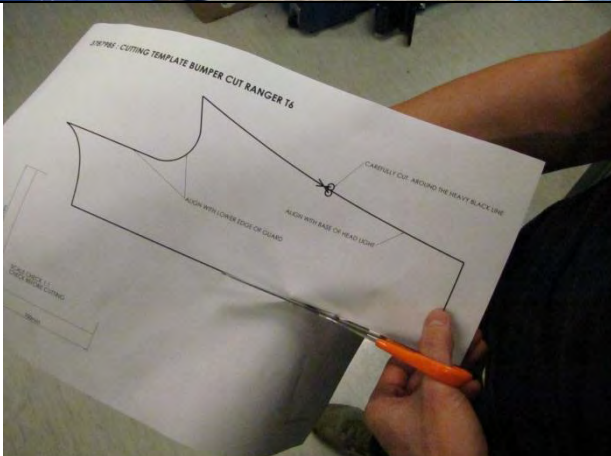

108. Using scissors carefully cut out the supplied paper template 3787985 for Ranger PX 2011-15.

FITTING PROCEDURE

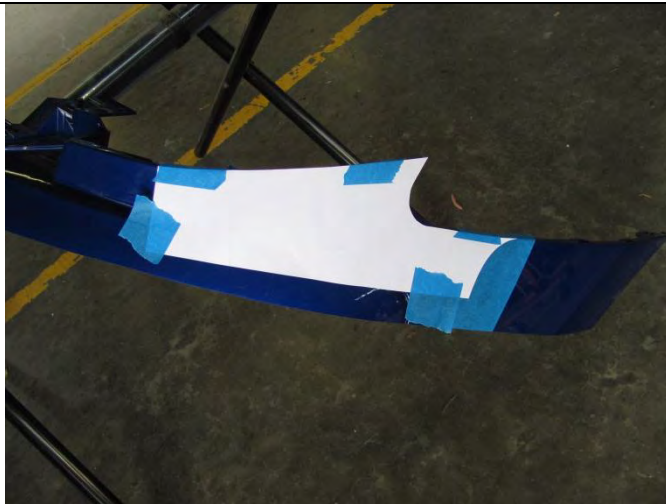

109. Attach the template to the bumper as shown using masking tape.
110. Place a piece of masking tape on the bumper at the rear of the template as shown (this will be used to mark on).

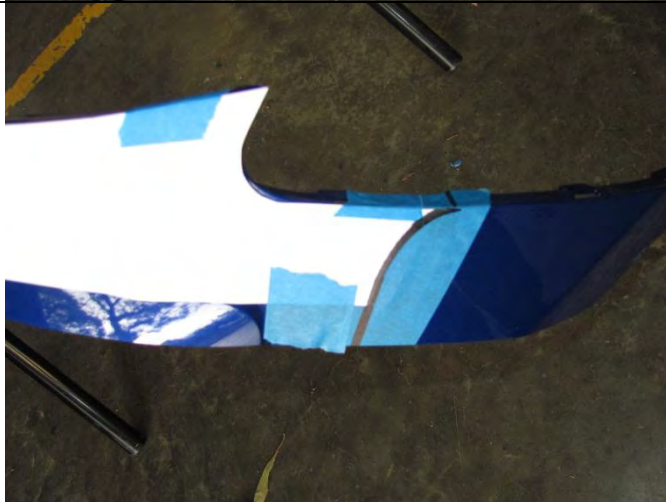

111. Using a marker pen, carefully trace a line along the rear most edge of the template continuing down the cut edge of the bumper.
112. Carefully remove the template and repeat on the opposite side of the vehicle by reversing the template.
113. Carefully cut along the marked lines removing the rear most sections of the bumper.

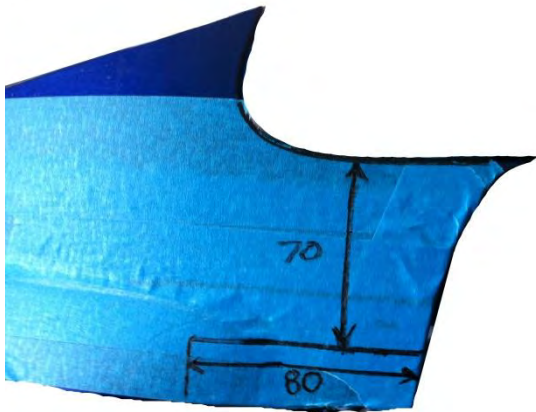

114. Mark 2 lines on each side of the bumper 70mm down from the edge that mates with the vehicles guard and 80mm from the rear most edge as shown.
115. Carefully cut along the marked lines creating a rectangular notch. Discard the cut piece.
116. De-bur the cut edges with a file or sandpaper.

Warning: Be careful when cutting and de-burring that you don't damage the paint on the visual surfaces of the bumper.



117. Mark the RH air deflector removed in step 65 as shown using the bottom edge of the lower mounting lug as a starting point across to the bottom corner of the opposite edge.
118. Carefully cut along the marked lines removing the lower off cut. Discard off cut.

FITTING PROCEDURE

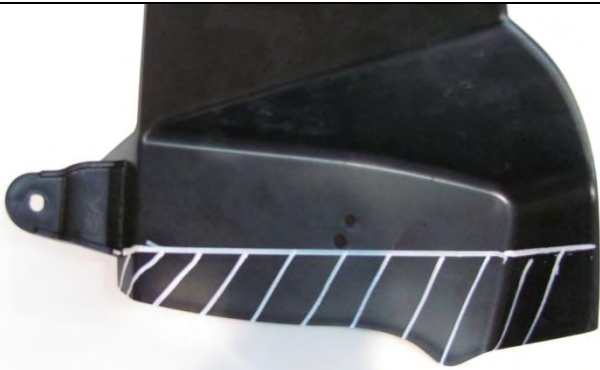

119. Mark the LH air deflector removed in step 66 as shown using the bottom edge of the lower mounting lug as a starting point, marking a line perpendicular to the vertical edge below the lug.
120. Carefully cut along the marked line removing the lower off cut. Discard off cut.



121. On both the RH and LH air deflectors, mark a line from the bottom corner of the lower mounting lug up to the forward / bottom edge of the bumper mounting lug as shown.
122. Carefully cut along the marked line removing the lower off cut. Discard off cut.
123. Refit the air deflectors to the vehicle using the 2 factory screws in each side.
124. Refit the bumper to the vehicle by reversing the removal steps.

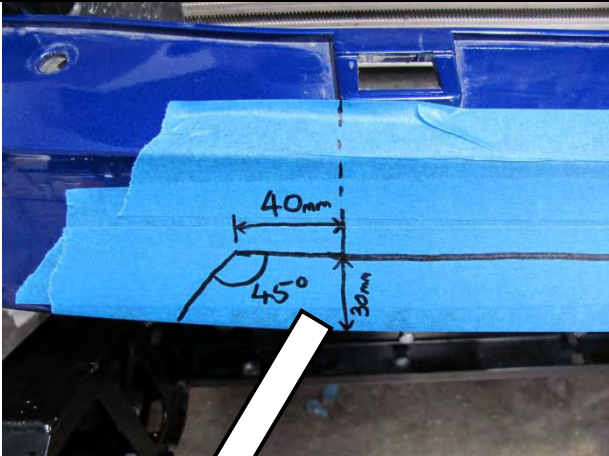

125. Tape the front centre face of the bumper as shown.
126. Using the outside edges of the 2 grille clip receivers on either side of centre as guides, mark vertical lines directly down the front of the bumper.
127. Mark a parallel line 30mm from the bottom edge of the bumper starting and finishing 40mm outboard of the vertical line marked above.
128. On both sides of the vehicle mark a line 45 degrees down to the bottom edge of the bumper.
129. Carefully cut along the marked lines. Discard the cut piece.
130. De-bur the cut edges with a file or sandpaper.

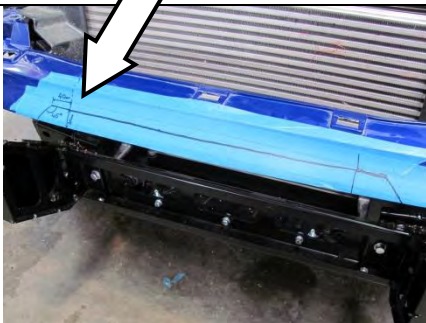

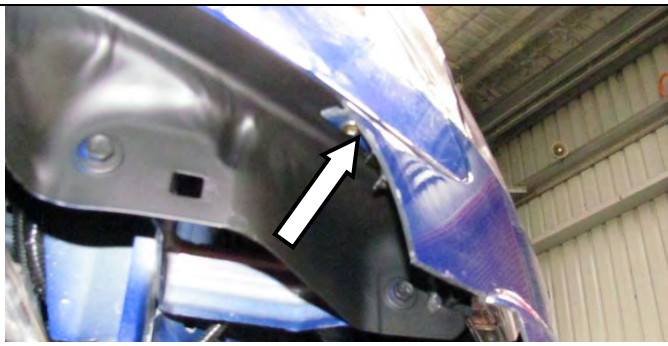

131. Drill a $\text{\O}2\text{mm}$ hole through each end corner of the bumper into the guard sheet metal.
132. Attach the bumper to the guards using the Phillips head self-tapping screws.

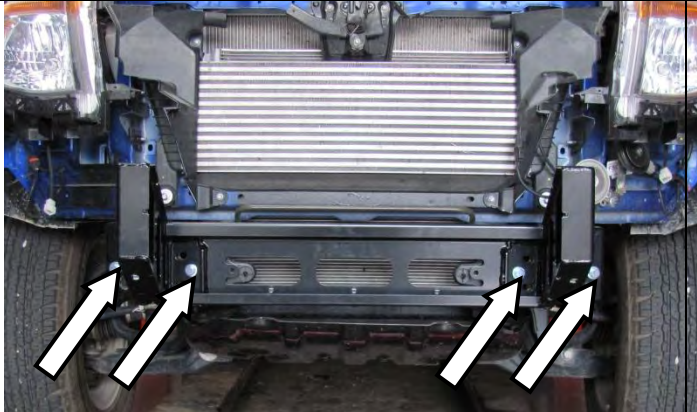

133. Attach the mount bracket to the chassis end plates using 4 X M10 SEMS bolts into the captive nuts. Leave loose at this stage.

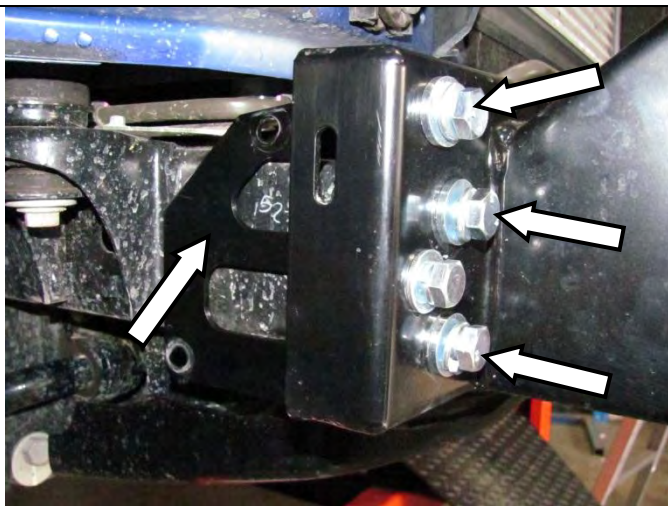

134. Place the right hand chassis brace onto the back of the chassis face plate and loosely attach it to the mount bracket using 3 X M12 bolts, 3 X M12 spring washers and 3 X M12 flat washers and 3 X M12 Flange nuts.
135. Repeat on the LH side.

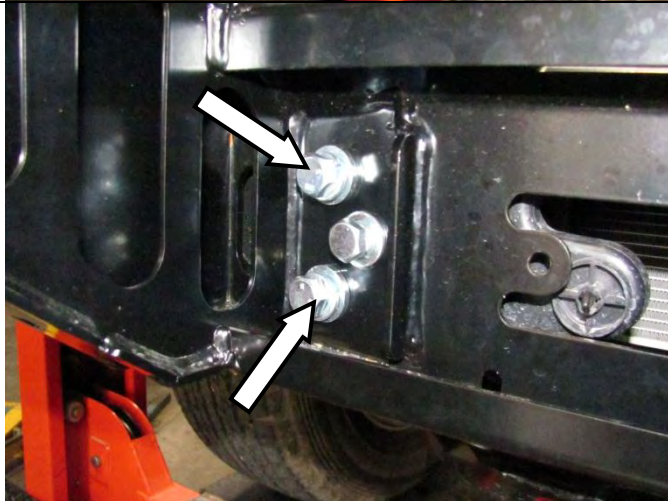

136. Place 2 X M12 bolts, 2 X M12 spring washers and 2 X M12 flat washers and 2 X M12 Flange nuts into the 2 holes on the inboard side of each chassis face plate. Leave loose at this stage.
137. Repeat on the LH side.

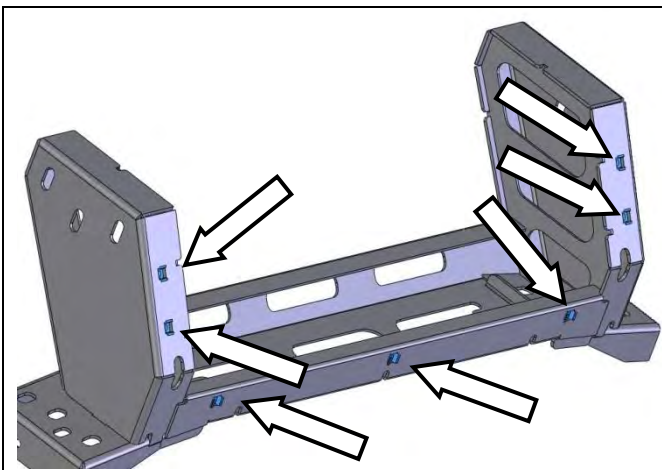

138. Fit 7 X M8 cage nuts into the mount bracket from the inside.

Note: A flat blade screw driver can be used to aid placement of the cage nuts.

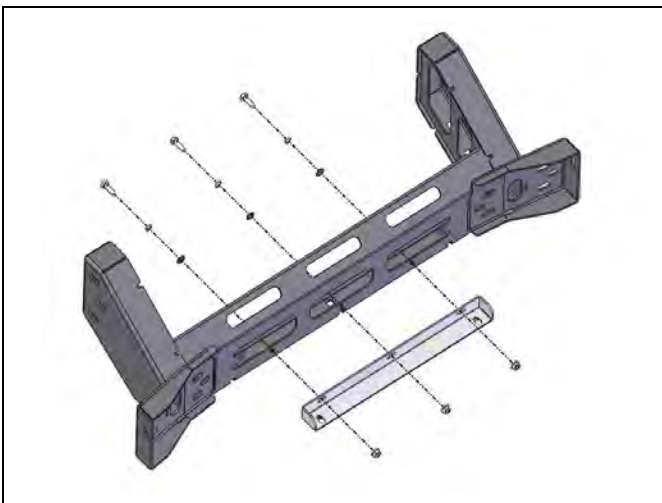

139. Attach the OE stone shield bracket to the chassis mount using 3 X M8 x 25 black bolts, 3 X M8 black flat washers, 3 X M8 black spring washers and 3 X M8 flange nuts. Leave loose at this stage.

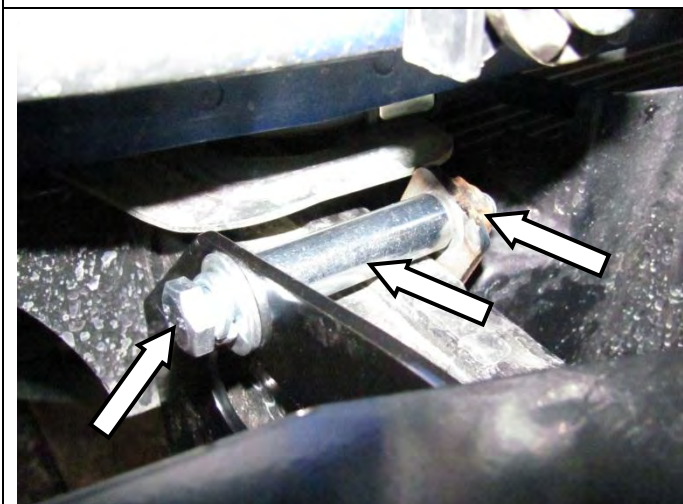

140. Secure the rear of the chassis braces to the chassis using 2 x M10 x 80 bolts, 2 x M10 spring washers and 2 x M10 flat washers through 2 x crush tubes into the nut plate assemblies on each side of the vehicle. Leave loose at this stage.

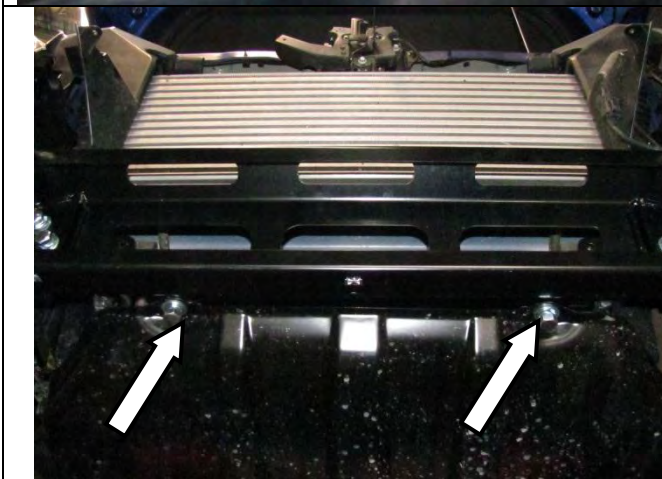

141. Re fit the OE stone shield to the bracket fitted in step 81 using 2 x M10 SEMS bolts and 2 x M10 flange nuts.



M10 - 44 Nm

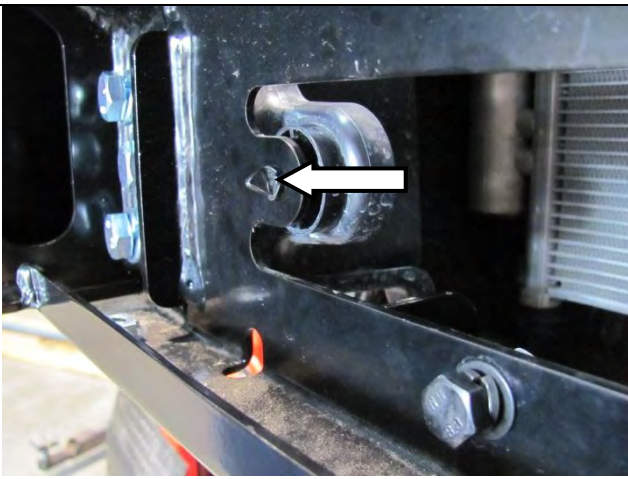

142. Using the original plastic clips re-fit the factory air deflector to the 2 holes in the mount bracket.

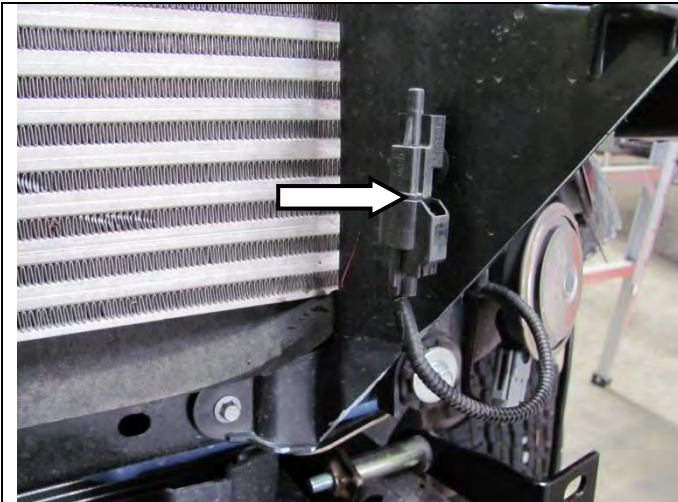

143. Using the pegs on the sensor removed in step 9/66 as a guide, Drill two Ø5.5mm holes in the LH air deflector so that the sensor can be fitted approximately 40mm forward of the rear edge of the air deflector as shown.

144. Push the pegs into the drilled holes, attaching the sensor.

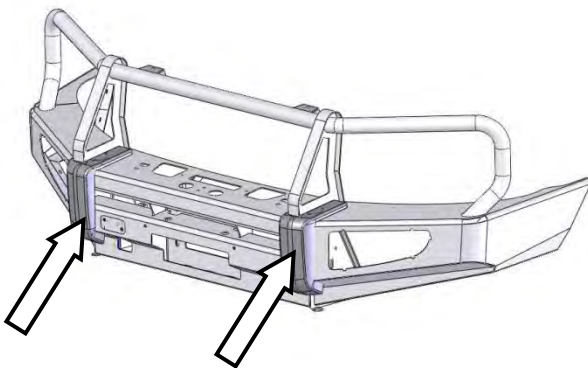

145. Place the bar face down on a surface that will not damage it.

146. Attach the buffers to the bar as shown using 12 x M6 flange nuts.

Warning: Do not over tighten the nuts or you risk pulling the studs from the buffers.

 M6 - 9 Nm.

If fitting a winch refer to fitting instructions 3787989 supplied with 3540050 winch install kit.

If not proceed to step 89



147. Fit 3 x M12 cage nuts to each of the cage nut plates.

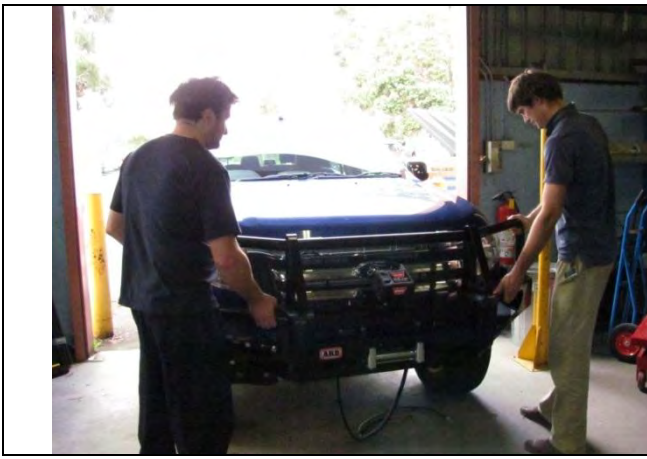

148. With the assistance of another person, place the bar on the mount brackets.

Warning: Due to the weight of the bar and winch if fitted, it is advised that you use some form of mechanical assistance when lifting the bar onto the vehicle such as an elevating trolley.

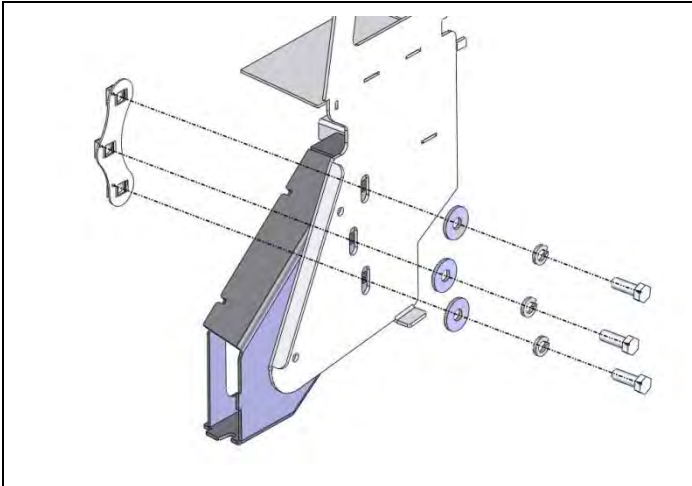

149. Attach the bar to the mount bracket using 6 x M12 bolts, 6 x M12 spring washers and 6 x large diameter M12 flat washers, into the nut plates which are placed inside the box upright sections of the mount bracket. Leave loose at this stage.



150. Position the bar so that it is level and there is a gap between the top face of the wings and the bottom edge of the guards, for 2011-15 PX of 18-22mm and 15ON PX2 25-30mm. The wing tips are to be aligned with the edge of the wheel arch.

NOTE: On the 2015on PX2 Ranger the gap can be between 25-30mm

151. Centralise the bar and tighten all mounting bracket related fasteners to the specified torque.

152. Tighten the bar to mount fasteners to the above specified torque.

 M10 - 44 Nm.  M12 - 77 Nm.

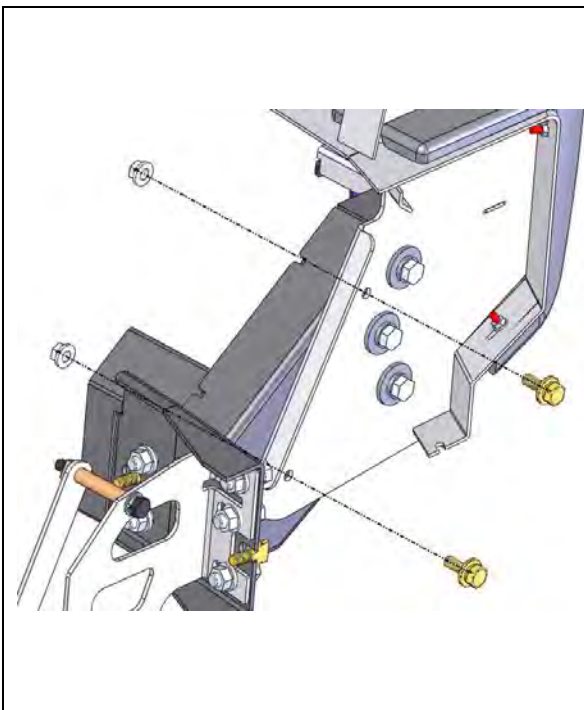

153. Double check the position of the bar.
154. If happy with the position of the bar drill four Ø10mm pinning holes using the pre-cut holes in the bar uprights as guides.
155. Use paint or rust protection on the drilled holes.

Warning: Drilling operations can result in flying metal debris, safety glasses should be worn.

156. Pin the holes using 4 x M10 SEMS bolts and 4 x M10 flange nuts.



M10 - 44 Nm.

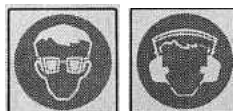

157. If fitting driving lights it is advisable to fit them now.

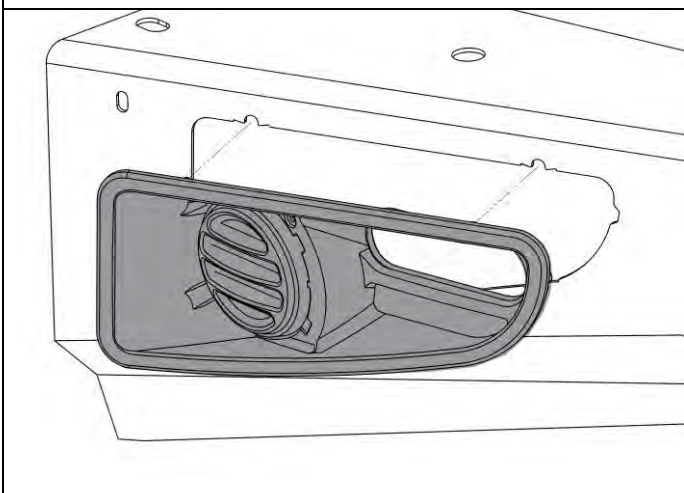

158. Assemble and install combination light surrounds (p/n 3163015) as per instructions no. 3786421 supplied with surround kit. Note: Optional fog lamps can be installed at this point as per fitting instruction no. 3783315 supplied with fog lamp kit no. 6821201.

CAUTION: Cable-tie all cables together and keep all cables clear of sharp edges and all moving parts.

159. Check the operation of all lights wired during bar fitment

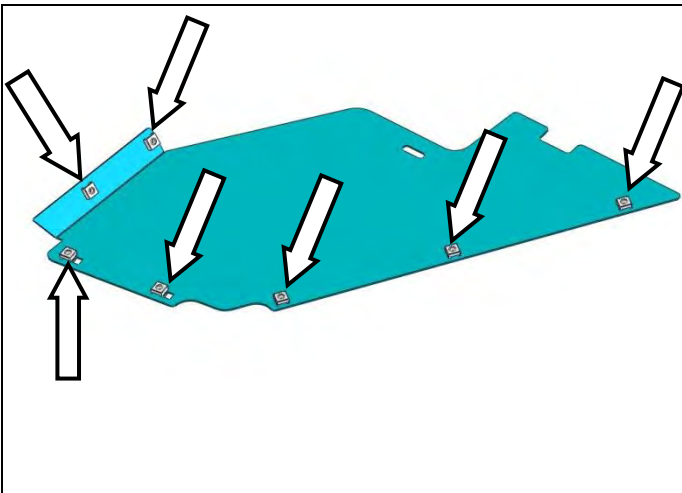

160. Fit 7 x M6 cage nuts to each of the under wing panels as shown.



161. Fit the RH under wing panel to the RH wing as shown and attach using 5 x M6 hex bolts, 5 x M6 spring washers and 5 x M6 flat washers.

162. Repeat on the LH side.

 M6 - 9 Nm.

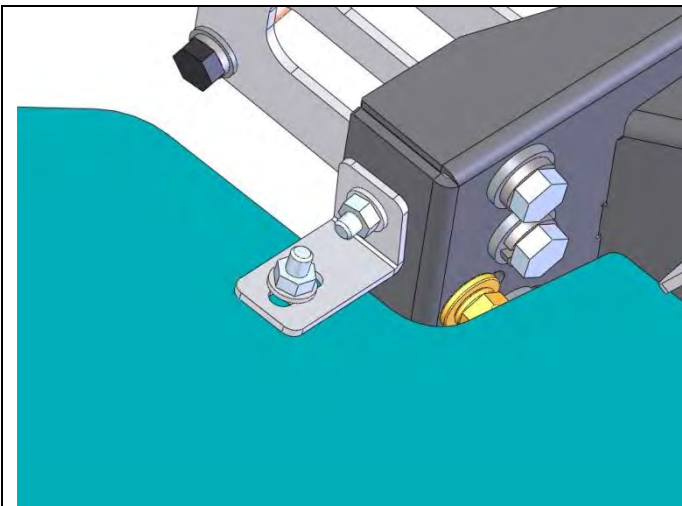

163. On each side of the bar attach the under wing panel to the mount bracket with the wing panel bracket using 2 M8 hex bolts, 2 M8 spring washers, 2 M8 flat washers and 2 M8 flange nuts.

 M8 - 22 Nm.



164. On the plastic OE inner guards, mark lines from the bottom corners of the bar wing tips down to the square corners in the inner guards. Continue the line along the horizontal corner.

165. Using scissors, sheers or a sharp knife, carefully cut along the marked line and discard the bottom section.



166. Mark and drill 2 x Ø7mm holes through each of the inner guards in line with the cage nuts.

Tip: Removing the front wheels will aid access for this task.

167. Attach the inner guards to the under wing panels using 2 x M6 hex bolts, 2 x M6 spring washers and 2 x M6 flat washers on each side of the vehicle.



M6 – 9Nm

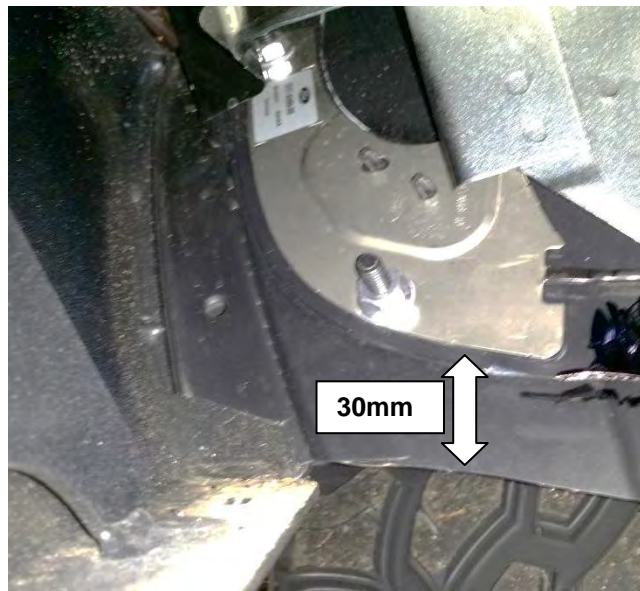

168. Remove wing under panel.

169. Position digital antenna removed in step 46, 30mm above cut performed on wheel arch guard as shown.

170. Mark and drill two Dia 10mm holes corresponding to existing holes in digital antenna.

171. Fasten digital antenna to new location using 2x M8 x 1.25 x 25 BTN HD bolts, 2x M8 spring washers, 2x M8 flat washers and 2x M8x1.25 flange nuts.

172. Plug digital antenna lead back in and check its function by turning radio on.

173. Re-fit wing under panel and tighten fasteners.

174. Push the inner guards inside the under wing panels.



M6 – 9Nm



M8 – 22Nm

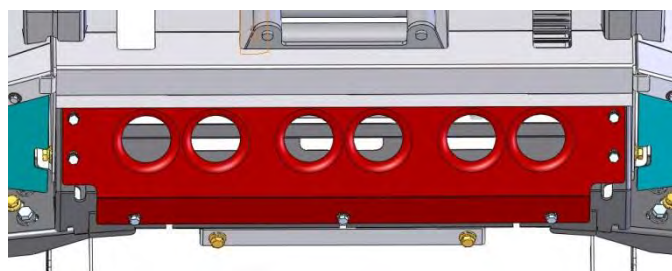

175. Attach the centre stone shield to the mount bracket using 7 M8 hex bolts, 7 M8 spring washers and 7 M8 flat washers into the cage nuts fitted in step 139.



M8 – 22Nm



176. Fit the plastic plugs into the square holes in the lower pan. Fit the number plate to the bull bar using the black self-tapping screws.

FITTING PROCEDURE (IF NOT FITTING WINCH)



Applying trim rubber, note the join is at middle of the rear of the plate or long side.

177. Fit rubber extrusion to cover panel as shown starting and finishing at the centre of the large radius side which is the back, then trim to length.



178. Fit the panel to the top of the bull bar as shown using M6 pan head stainless steel screws, M6 flat ss washers and M6 flange nuts.



M6 – 9Nm

NOTICE: ONCE BULL BAR IS FITTED:

- ◆ Ensure all bolts are tensioned correctly.
- ◆ All wiring is clear of sharp edges or moving surfaces and is secured properly.
- ◆ Piping is secured well clear of sharp or moving components.
- ◆ Check operation of winch if fitted.
- ◆ Check all wiring and connections to turn signal lamps, sensors, headlamp washers etc. are functioning correctly.

FITTED PRODUCT

PX RANGER 2011-2015



PX2 RANGER 2015ON



WIRING DIAGRAM (PX RANGER 2011-2015)

