



FITTING INSTRUCTIONS

- Part Number: 3914510 – 2005 to 2011 SAHARA BAR (NO INDICATORS)
- Suited to vehicle/s: HILUX – 2005 to 2011 WITH FLARES - (SRS AIR BAG EQUIPPED MODELS).
ARB WINCH/NON WINCH BUMPER- NO INDICATORS.
- Fitting Kit:
- 5100070: Top Tube Kit
 - 5100020: Buffer Kit – With hole (required when fitting Top Tube)
 - 5100030: Buffer Kit – With No Hole
- Optional Fitting Kit:
- 3500530 – ARB AUX FOG LIGHT LOOM. (NON FACTORY FOG LAMP INSTALLATION).
 - 3500590 – ARB FFR FOG LIGHT KIT (FOR NON FACTORY FOG LAMP VEHICLES).
 - 3500680 – FOG LAMP HOUSING CLEAR LENSE KIT
 - 3540050 – WINCH INSTALL KIT.
 - 3500610 – ZEON WIRE ROPE F/KIT.
 - 3500620 – ZEON SYNTHETIC ROPE F/KIT.

WARNING

NOTE THE FOLLOWING: -

- ◆ This product must be installed exactly as per these instructions using only the hardware supplied.
- ◆ In the event of damage to any bull bar component, contact your nearest authorised ARB stockist. Repairs or modifications to the impact absorption system must not be attempted.
- ◆ Do not use this product for any vehicle make or model, other than those specified by ARB.
- ◆ Do not remove labels from this bull bar.
- ◆ This product or its fixing must not be modified in any way.
- ◆ The installation of this product may require the use of specialized tools and/or techniques
- ◆ It is recommended that this product is only installed by trained personnel
- ◆ These instructions are correct as at the publication date. ARB Corporation Ltd. cannot be held responsible for the impact of any changes subsequently made by the vehicle manufacturer
- ◆ During installation, it is the duty of the installer to check correct operation/clearances of all components
- ◆ Work safely at all times
- ◆ Unless otherwise instructed, tighten fasteners to specified torque

ARB 4x4 ACCESSORIES

Corporate Head Office

42-44 Garden St
Kilsyth, Victoria
AUSTRALIA 3137

Tel: +61 (3) 9761 6622
Fax: +61 (3) 9761 6807

Australian enquiries
North & South American enquiries
Other international enquiries

sales@arb.com.au
sales@arbusa.com
exports@arb.com.au

www.arb.com.au

GENERAL CARE AND MAINTENANCE

By choosing an ARB Bar, you have bought a product that is one of the most sought after 4WD products in the world. Your bar is a properly engineered, reliable, quality accessory that represents excellent value. To keep your bar in original condition it is important to care and maintain it following these recommendations:

- Prior to exposure to the weather your bar should be treated to a Carnauba based polish on all exposed surfaces. It is recommended that this is performed on a six monthly basis or following exposure to salt, mud, sand or other contaminants.
- As part of any Pre Trip Preparation, or on an annual basis, it is recommended that a thorough visual inspection of the bar is carried out, making sure that all bolts and other components are torqued to the correct specification. Also check that all wiring sheaths, connectors, and fittings are free of damage. Replace any components as necessary. This service can be performed by your local authorized ARB Stockist.

FITTING REQUIREMENTS

HAVE AVAILABLE THESE SAFETY ITEMS WHEN FITTING PRODUCT: -

Protective eyewear



Hearing protection



NOTE: 'WARNING' notes in the fitting procedure relate to OHS situations, where to avoid a potentially hazardous situation it is suggested that protective safety gear be worn or a safe work procedure be employed. If these notes and warnings are not heeded, injury may result.

REQUIRED TOOLS FOR FITMENT OF PRODUCT:

METRIC SOCKET SET	METRIC RING AND OPEN ENDED SPANNER SET
ELECTRIC DRILL 13 MM CAPACITY	5 & 10 mm DRILL BITS
BASIC TOOL KIT	PHILLIPS AND FLAT BLADE SCREW DRIVER SETS
TORQUE WRENCH (or WRENCHES Capable of covering from 3NM – 77NM)	ROLLS OF 25 mm & 50 mm WIDE MASKING TAPE
FELT TIP MARKER PEN	FINE FILE OR SAND PAPER
METRIC TAPE MEASURE or RULE	SCISSORS or SHARP KNIFE
TOUCH UP PAINT – BLACK FAST DRYING ENAMEL	STEPPED RING SPANNER TO SUIT 3/8" BOLT. (If installing a winch).

FASTENER TORQUE SETTINGS: -

SIZE	Torque Nm	Torque lb/ft
M6	9Nm	7lbft
M8	22Nm	16lbft
M10	44Nm	32lbft
M12	77Nm	57lbft

USE	PART No	QTY	DESCRIPTION
CONTROL BOX FITMENT (WINCH ONLY)	3756499	1	CONTROL BOX BRACKET
	6151234	2	BOLT, M8 x 1.25 x 25 LONG (BLACK)
	4581045	2	WASHER FLAT M8 (BLACK)
	6151132	2	NUT FLANGE M8
	EG50	2	GROMMET RUBBER
WINCH (8000/9000/9500 LB)	180302	8	CABLE TIES
	4581040	4	WASHER FLAT 3/8"
	6151074	2	BOLT UNC 3/8" x 1 3/4"
IMPACT ABSORBER TO BULL BAR	BLB850	3	CABLE BLACK 850mm
	6151304	4	NUT CAGE M10
	4581040	8	WASHER FLAT M10
	4581288	4	WASHER FLAT M10 (OVER-SIZED)
	4581048	8	WASHER, SPRING, M10
	6151232	8	BOLT, M10 x 1.5 x 30 LONG
NUMBER PLATE TO BULL BAR INSERT TO BULL BAR	6151026	4	NUT, HEX, M10 x 1.5
	6821189	2	PLASTIC GROMMET
WING TRIM FITMENT	6151384	2	SCREW PAN HD PHIL BLK 5 X 16mm
	3163001R	1	TRIM, WING (LH), HILUX 05
	3163001L	1	TRIM, WING (RH), HILUX 05
	4581082	10	WASHER, FLAT, M6 (BLACK, 20 OD)
IMPACT ABSORBER TO CHASSIS	6151162	10	NUT, NYLOC, M6x1
	3758412R	1	BRKT ASSY IMPACT HILUX UPDATE
	3758412L	1	BRKT ASSY IMPACT HILUX UPDATE
	4581040	4	WASHER, FLAT, M10
	4581048	4	WASHER, SPRING, M10
CHASSIS STIFFENING PLATE TO CHASSIS & IMPACT ABSORBER	6151133	4	NUT, M10 x 1.25
	3199756R	1	PLATE (RH), CHASSIS, HILUX 05
	3199756L	1	PLATE (LH), CHASSIS, HILUX 05
	6151234	2	BOLT, M8 x 1.25 x 25 LONG (BLACK)
	6151088	6	BOLT, M10 x 1.25 x 35 LONG
	4581040	12	WASHER, FLAT, M10
	4581045	2	WASHER, FLAT, M8 (BLACK)
	4581048	6	WASHER, SPRING, M10
	4581047	2	WASHER, SPRING, M8 (BLACK)
LOWER GRILL BRACKET	6151133	6	NUT, M10 x 1.25
	3756725	1	BRKT GRILL MNT HILUX 05
	6151234	2	BOLT, M8 x 1.25 x 25 LONG (BLACK)
	4581045	2	WASHER, FLAT, M8 (BLACK)
	4581047	2	WASHER, SPRING, M8 (BLACK)
FOG LAMPS TO BULL-BAR	6151132	2	NUT FLANGE M8
	3163082	1	KIT SURROUND ARB FOGLIGHT
CENTRE STONE DEFLECTORS	6821183	2	FOG LAMP LOOM EXTENSION 55W
	6522650	1	PANEL STONE GUARD LOWER HILUX 05
	6522926	1	PANEL STONE HILUX UPDATE
	6151315	2	CAGE NUT, M6 (1.6mm PLATE)
	6151303	6	CAGE NUT, M8 (3mm PLATE)
	4581082	2	WASHER, FLAT, M6 (BLACK, 20 OD)
	4581287	2	WASHER, SPRING, M6 (BLACK)
	6151213	2	BOLT, M6 x 1.0 x 20 (BLACK)
	4581045	6	WASHER, FLAT, M8 (BLACK)
	4581047	6	WASHER, SPRING, M8 (BLACK)
	6151234	6	BOLT, M8 x 1.25 x 25 LONG (BLACK)

ITEMS SHOWN IN SHADED AREA ARE FOR WINCH FITMENT.

USE	PART No	QTY	DESCRIPTION
WING STONE DEFLECTORS	6522653R	1	PANEL WING HILUX 05 (RH)
	6522653L	1	PANEL WING HILUX 05 (LH)
	6151315	10	CAGE NUT, M6 (1.6mm PLATE)
	4581082	10	WASHER, FLAT, M6 (BLACK, 20 OD)
	4581287	10	WASHER, SPRING, M6 (BLACK)
	6151213	10	BOLT, M6 x 1.0 x 20 (BLACK)
	6151094	2	BOLT M12 x 1.25 x 30 LONG
	4581049	2	WASHER, FLAT M12
	4581050	2	WASHER, SPRING M12
180302	4	CABLE TIES	
WINCH COVER PANEL	6522661	1	PANEL WINCH COVER
	6151256	2	BUTTON HEAD SCREW M6 x 16mm
	4581304	2	WASHER FLAT M6 S/S
	6151128	2	FLANGE NUT M6
	6191005	1	WINCH COVER EXTRUSION
AERIAL PLUGS	3162152	2	CB AERIAL CAP
BUFFERS TO BULL BAR (5100020 REQUIRED IF FITTING TOP TUBE)	3162469R	1	BUFFER (RH)
	3162469L	1	BUFFER (LH)
	6151128	12	NUT FLANGE M6
BUFFERS TO BULL BAR (5100030 REQUIRED IF NOT FITTING TOP TUBE)	3162466R	1	BUFFER (RH)
	3162466L	1	BUFFER (LH)
TOP TUBE TO BULL BAR (5100070)	6131371	1	TOP TUBE ASSEMBLY
	6151255	2	BOLT M12 x 1.75 x 40 mm LONG
	4581049	2	WASHER M12 FLAT
	4581050	2	WASHER M12 SPRING

ITEMS SHOWN IN SHADED AREA WILL BE SUPPLIED DEPENDENT ON CHOSEN BAR CONFIGURATION.

NOTE:

- ◆ FITS ARB INTENSITY DRIVING LIGHTS.
- ◆ FITS IPF DRIVING OR FOG LIGHTS UP TO 900 SERIES ROUND OR 800 RECTANGULAR.
- ◆ SUITS WINCHES WARN ZEON AND LOW MOUNT UP TO 10K, BUSHRANGER AND SMITTYBUILT.

PREPARATION TO VEHICLE

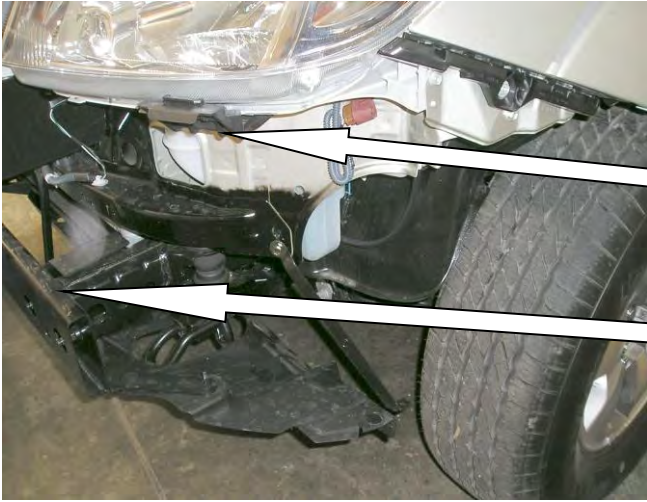

1. Remove existing bumper and grill from the vehicle.
Once these are removed:
 - Remove the light bracket fitting and discard; this is done by first removing the light and then unscrewing the bracket from the rear of the light fitting.
 - Remove the bumper braces and discard.

If Factory Fog Lamps are fitted to the vehicle and are to be re-used, remove carefully from bumper and set aside.



2. Spray paint the metal underside of the fender and the underside of the headlamp black.

Ensure the area to be painted is well masked to ensure no over spray on other components.

3. Once paint has fully dried, remove masking.



4. Remove the protruding bracket in front of the radiator, as it is no longer required (note: the vertical member of this bracket must not be removed as it holds the bonnet latch in position). This may be done by either drilling out the existing spot-welds with a 5mm drill as shown, or by cutting it off with a grinder. Re - locate the air temp sender (if fitted) to one of the holes in the vertical bracket.



Warning: Cutting operations can result in flying metal debris. Safety glasses should be worn.

5. ***Paint exposed metal to prevent rusting.***
 - ***Ensure the area to be painted is well masked to ensure no over spray on other components.***

PREPARATION TO VEHICLE

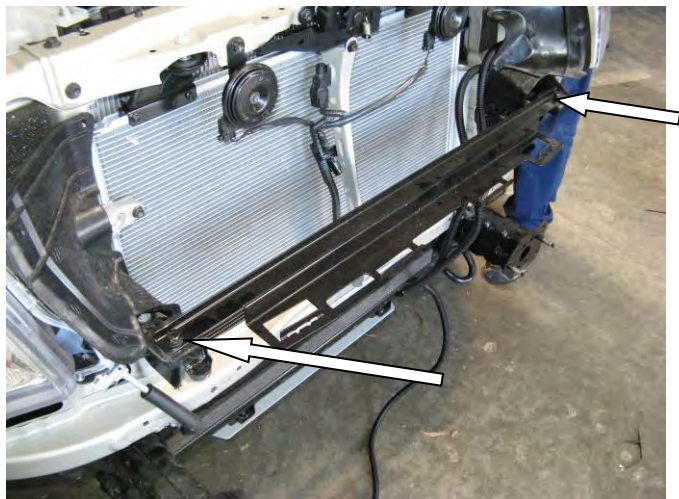

6. Fasten the lower grill bracket to the vehicle head lights, as shown, using M8 x 25 black bolts, flat washers, spring washers and flange nuts.

Torque to specification.



7. Reassemble the vehicle's grill removed at Step 1; make sure the 2 x lower grill tabs are pushed into the clips in the lower grill bracket. Bend lower grill bracket tab upwards slightly.

PREPARATION TO BULLBAR



8. Fit the buffers to the bull-bar using the 6mm flange nuts provided.

(DO NOT OVER TIGHTEN)

FOR WINCH BUMPER BARS, FIT BUFFER WITHOUT TOP TUBE HOLES.

PREPARATION TO BULLBAR



9. Push the Top Tube through the Buffer holes and fasten using the M12 x 40mm bolts, Flat and Spring Washers.

FOR WINCH BUMPERS, SKIP THIS STEP.

NOTE:

Torque these M12 fasteners to 44Nm only (Critical)



10. If using Top Tube, insert plastic CB aerial caps into top face of Bullbar beside Buffers.



11. (If Winch is not to be fitted), prepare Winch access Hole cover plate by fitting rubber trim around the edge starting from the middle of the back edge. Trim excess.

12. Secure to top Pan using 2 x M6 x 16 S/S Button head bolts, Washer underneath bolt head and M6 Flange Nut to fasten.

PREPARATION TO BULLBAR

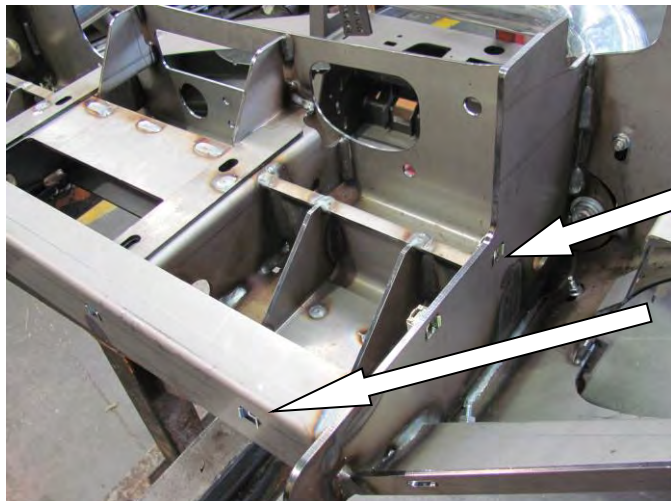

13. Fit caged nuts to the bull-bar.

NOTE:

M10 caged nuts. (4 off) Caged portion is to centre of bull bar.

M8 caged nuts. (4 off) Caged portion is to top of bull bar.



14. Loosely fit the wing trims using 5 x oversized M6 washers, 4 x M6 nyloc nuts and 1 x self-tapping screw on each side of the bar

These nuts will be tightened after the bar has been fitted to the vehicle and the wing trims have been positioned in an optimal position. (Step 41).

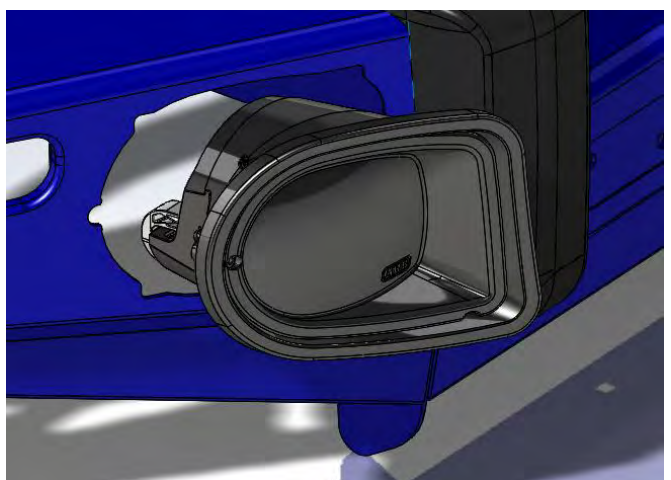

15. Fit fog lamp housings (3163082) into the bull-bar fog lamp cutouts as shown.

(RH Shown).

If fitting fog lights (ARB or OE) refer to fitting instructions (3789190) in the fog lamp housing kit (3163082) for details before mounting the housings in the bull-bar.

PREPARATION TO BULLBAR

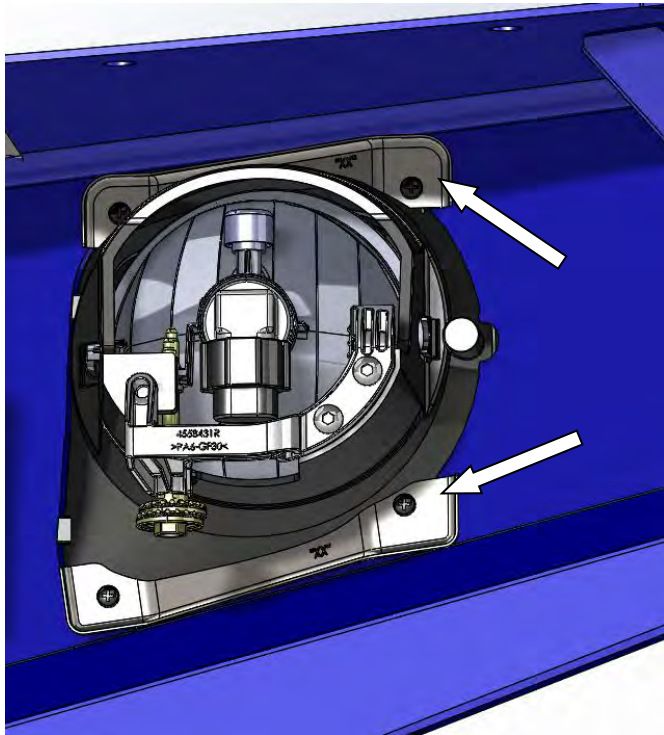

- Secure into position as indicated using the 2 x fog lamp clamps and 4 x self-tapping screws. **Note: Clamps and Screws are supplied in 3163082 – Kit Surround ARB Fog Housing.**

(RH Clamps Part No. 3759115R).
(LH Clamps Part No. 3759115L).

Note: 19w Factory Fog Lamp fitted in this view.

WINCH FITMENT ONLY

TO FIT A WINCH BAR

(If not fitting a winch proceed to Step 36)

- To fit a Warn Zeon/8/9/9500lb winch, rotate gearbox 72° counterclockwise.
- Stand the winch upright and undo the capped head screws. Lift the gearbox up - only a couple of millimeters, to allow the gearbox to be rotated to the new position. Once in position, refit all screws and tighten firmly.

WARNING: Do not lift gearbox more than a couple of millimeters.

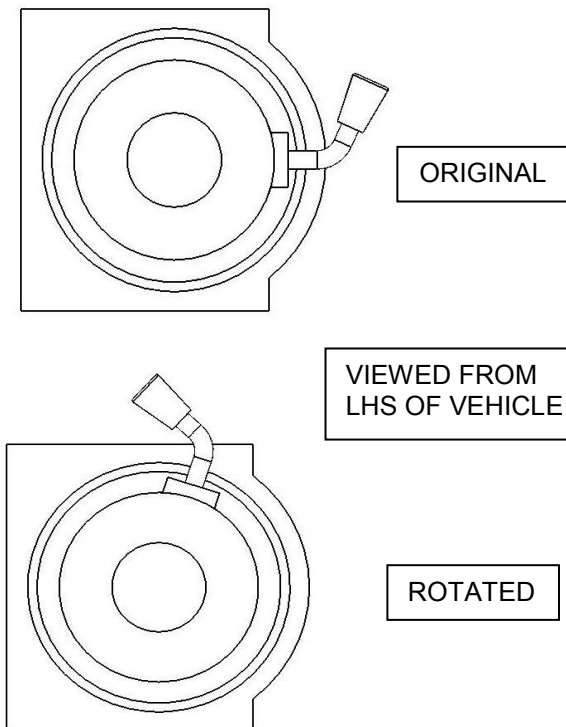

WINCH FITMENT ONLY

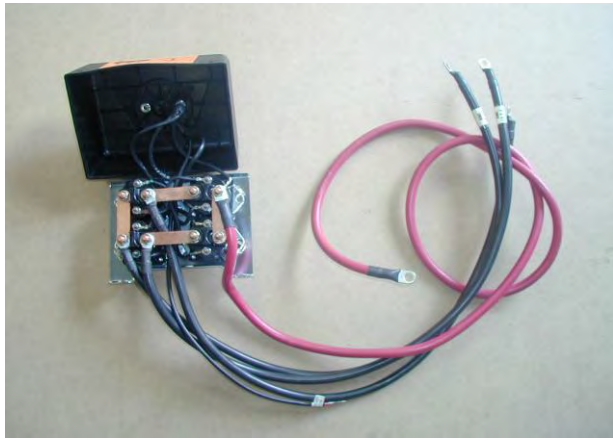

19. Remove the cover from the control box.
20. Replace the three main power cables that go from winch to control box. Make sure that you identify the colour codes on the new cables before closing control box cover.
21. This must be done for whatever winch is to be fitted to the bull bar.

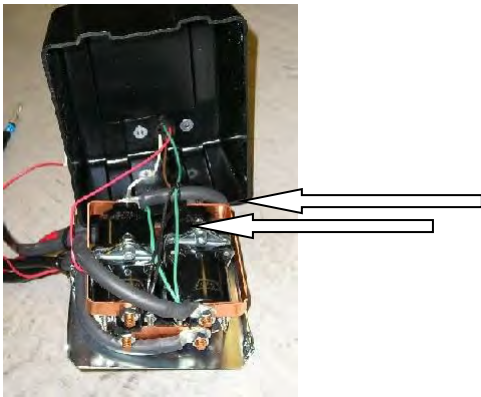

22. If fitting the XP 9.5 winch, remove the cover from the control box, otherwise proceed to Step 28.
23. Remove the two cap screws, nuts and spacer washers that hold the four solenoids in place.

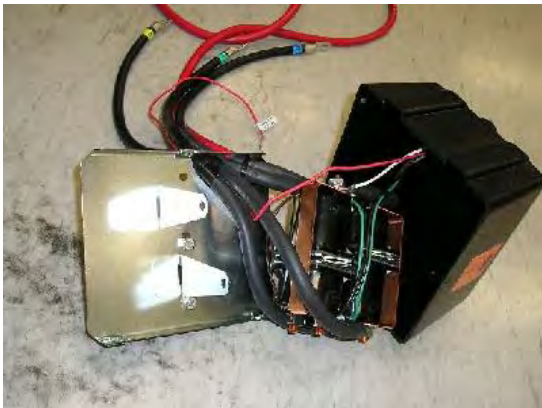

24. Remove the four solenoids from the base of the control box using the copper bus bar as an aid and hold to one side.

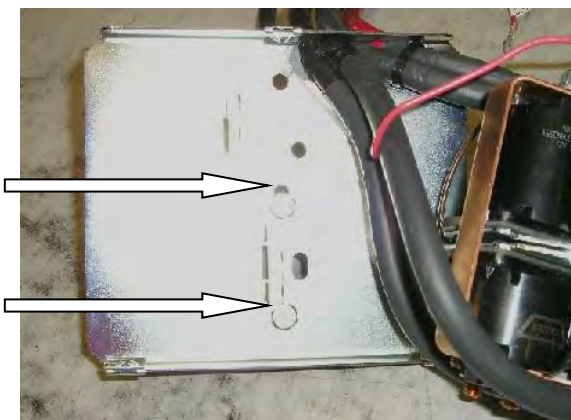

Before

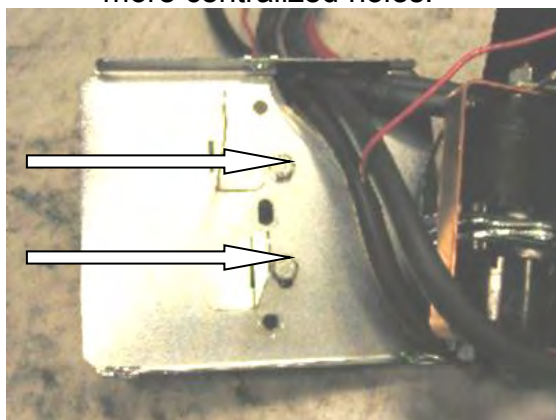

After

25. Remove the two bolts in the base of the control box and reposition them into the more centralized holes.

WINCH FITMENT ONLY



26. Place the 4 solenoids over the 2 metal stands that are facing upwards. Make sure they line up with the holes in the base.

27. Replace the 2 x cap screws, washers and nuts removed in Step 23 into original holes.

Replace the black cover and refit the three cover screws. (DO NOT OVER TIGHTEN)



28. Bolt the control box bracket to the control box.

29. Fit the two grommets into the round holes in the top of the bull bar then thread the cables through.

30. Mount the control box bracket onto the top pan, using M8 bolts, flat washers and flanged nuts. Use the cable ties to ensure the winch cables are secure, clear of moving parts and sharp edges and tie them together.

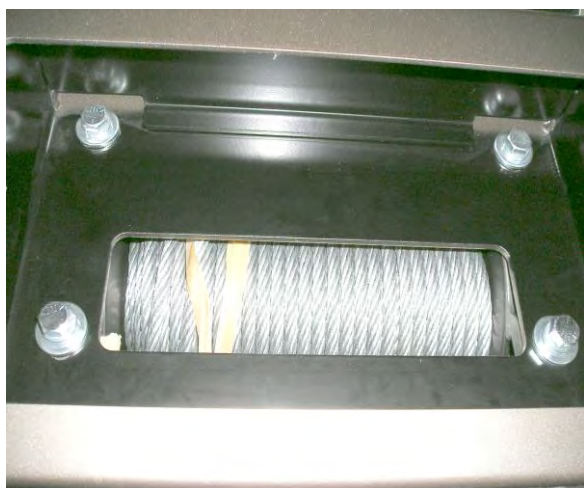

31. Place winch on a stand with mounting holes facing upwards and lower the bull bar onto the winch. Align all four holes, using the original 3/8" bolts that came with the winch in the top two holes and the longer 1 3/4" x 3/8" bolts, supplied in the kit, in the lower two holes plus 3/8" spring and flat washers with each bolt.

32. When all bolts are fitted and finger tight, tighten top holes only, using a stepped ring spanner and remove lower bolts.

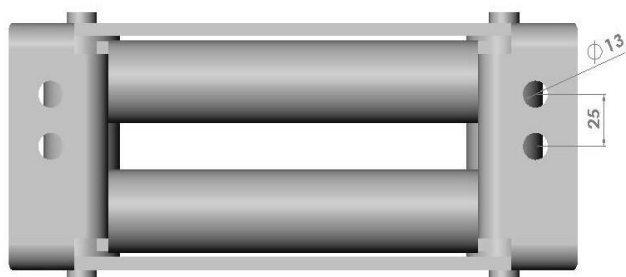

33. Drill two new 13mm holes in the roller fairlead provided in the kit, as shown on the adjacent picture.

WINCH FITMENT ONLY



34. Fit roller fairlead into cutout and refit bolts and tighten firmly.

NOTE. For ease of tightening the lower bolts, use a stepped ring spanner.

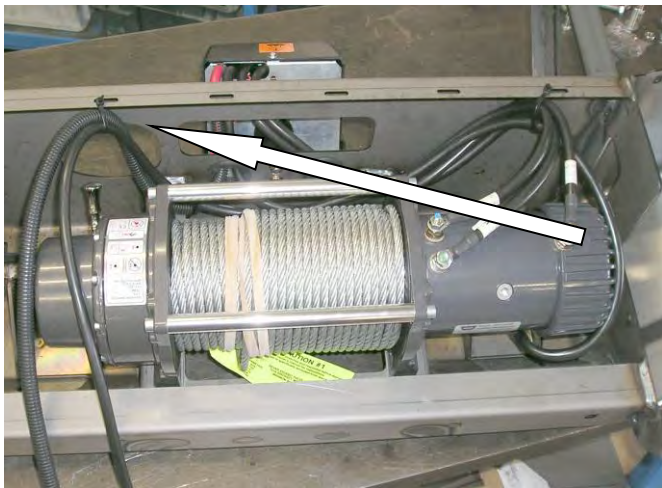

35. Connect the winch control box cables to the winch. Refer to Warn installation instruction manual when wiring up winch.

Refer to photo to see where to cable tie to the bull-bar.

*Ensure that all cables are installed well clear of all sharp or moving parts, by using cables ties from bolt kit.

*Cable tie main cables that go to battery in between underside of bar and brace.

BULLBAR FITMENT TO VEHICLE

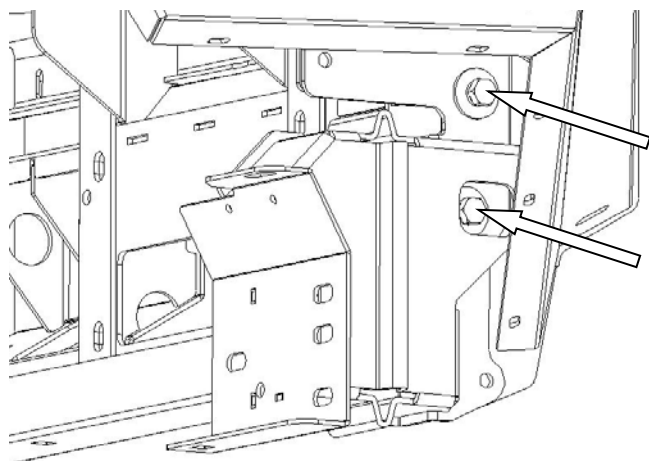
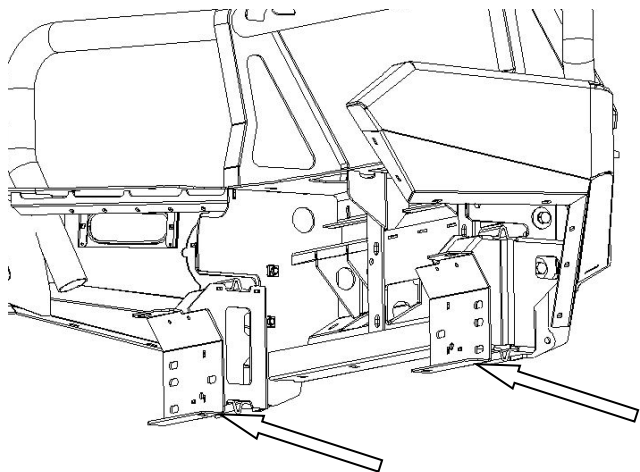

36. Fit the impact absorbers to the bull-bar (as shown) using the 4 x M10 x 30 bolts, M10 over-sized washers and M10 spring washers. Do not fully tighten these bolts at this time as they will be tightened on the vehicle - Step 39.

(RH Shown – Generic image).

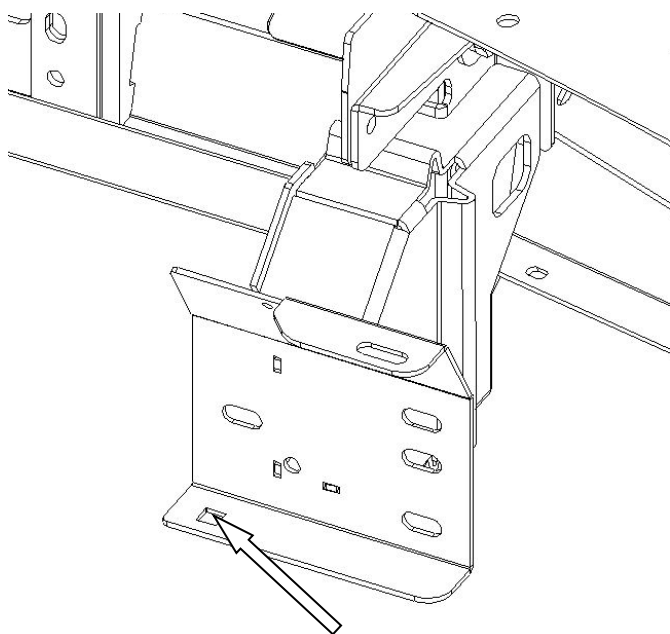

37. Fit M8 Cage Nuts (2 off) to the LH & RH Impact Absorbers. Caged portion is on the upper side of the mount plate.

(RH Shown).

BULLBAR FITMENT TO VEHICLE



38. Position the bar on the vehicle and fasten it to the chassis studs using the 4 x M10 washers, spring washers and nuts provided. Once satisfied that the bar is centrally positioned on the vehicle fully tighten the M10 nuts.

Note: There is 2 x Chassis Studs on RH and 2 x Chassis Studs on LH mounts - Only one stud visible in image.

Torque to specification.

 **M10 - 44 Nm.**



39. Adjust the bull-bar position up/down and in/out to achieve uniform gaps between the bar and the fenders on each side of the vehicle. The nominal clearance between the bull-bar and the fenders is 20mm. Once satisfied with fitting clearance torque to specification the M10 x 30 bolts fitted in Step 36.

 **M10 - 44 Nm.**

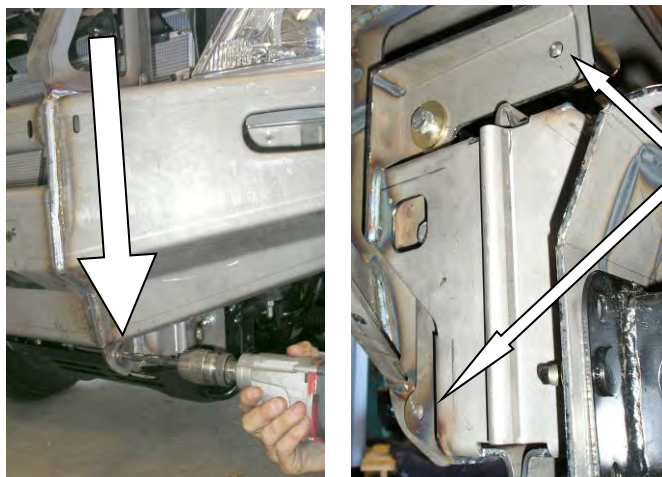

40. Once satisfied with the position of the bull-bar, using a 10mm drill bit, drill through the 10mm holes in the impact absorber, 2 holes per side, and secure using the M10 x 30 bolts, two flat washers per bolt, spring washers and hex nuts.



Warning: Cutting operations can result in flying metal debris. Safety glasses should be worn.

Torque to specification.

 **M10 - 44 Nm.**

BULLBAR FITMENT TO VEHICLE



41. On both sides of the vehicle position the wing trims to fit uniformly around the vehicles headlamps (attached to the bull-bar at Step 14) and tighten the M6 nuts and self-tapping screws.

Torque to specification.

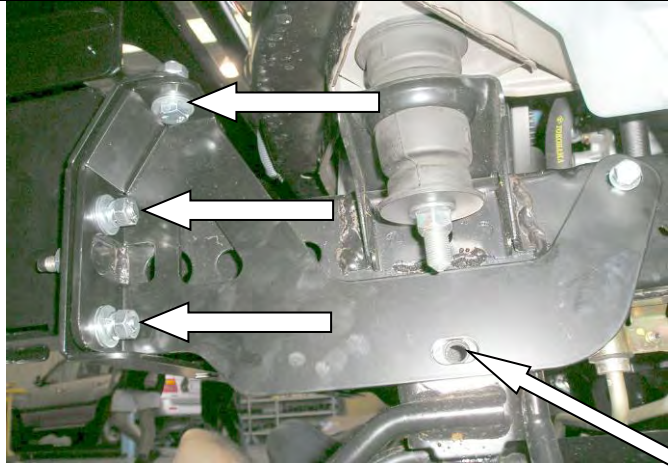
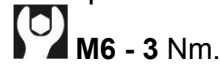

42. Fasten the chassis-stiffening bracket to the chassis and the impact absorber as shown. Fasteners required: M10 x 35 bolts – 6 off, M10 flat washers – 12 off, M10 spring washers – 6 off, M10 hex nuts – 6 off, M8 x 25 bolts – 2 off, M8 flat washers – 2 off, and M8 spring washers – 2 off.

Torque to specification.



Leave this bolt hole clear for Step 48.

43. Connect Fog Lamp wiring looms/plugs.

- **For Vehicles with Factory Fog Lamps - 55W:** Connect RH & LH Fog Lamp wiring using Loom Ext. Fog Light (6821183) between OE Fog Lamp plugs and 55W Factory Fog Lamps.
- **For ARB Fog Lamps - 3500590:** Connect RH & LH Fog Lamp wiring using Fog Light Wiring Loom kit – 3500530.

Cable tie **all** wiring and wiring looms into safe and convenient locations.

Ensure that all cables are installed well clear of all sharp or moving parts, by using cables ties from bolt kit.

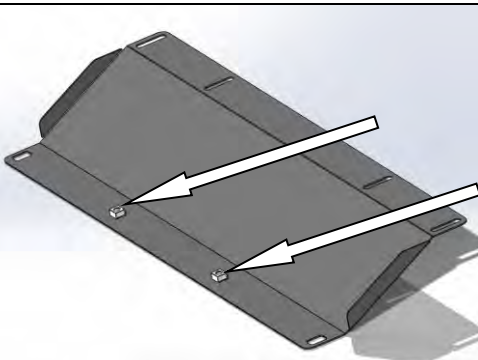

44. Fit M6 Caged Nuts to Centre Stone Guard as shown. Caged portion is on the upper side of the stone guard.

BULLBAR FITMENT TO VEHICLE

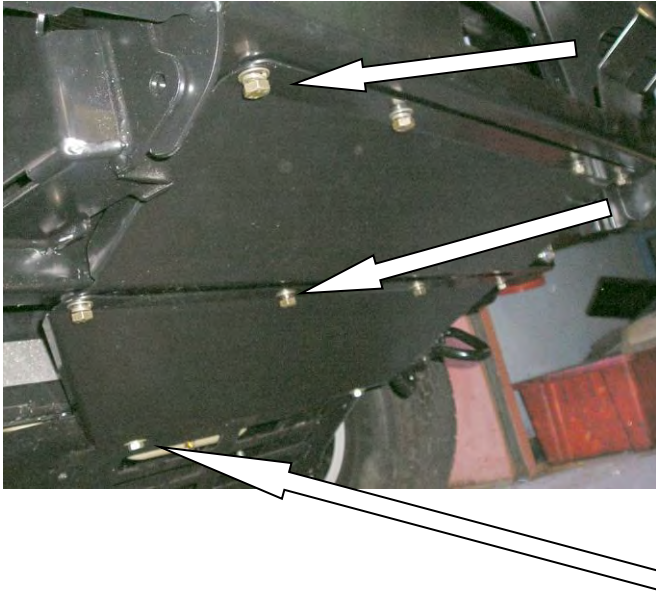

45. Fit the centre stone guards as shown using M8 x 25 black bolts, black M8 flat washers and black M8 spring washers.

Use 2 x M6 x 20 black bolts, black M6 flat washers and black M6 spring washers.

Torque to specification.

 M6 - 9 Nm.

 M8 - 22 Nm.

Use the original bolts in the lower two holes.



46. Fit the M6 cage nuts to the wing stone guards as shown. Caged portion on the top side of the wing stone guards.

47. Make sure the plastic wheel liner on the LH side of the vehicle has been disconnected from the washer bottle before fitting the wing stone guards.



48. Fit the wing stone guards to the bull bar / vehicle using M6 x 20 black bolts, M6 black washers, M6 black spring washers, M12 x 30 bolts, M12 washers and M12 spring washers.

BULLBAR FITMENT TO VEHICLE

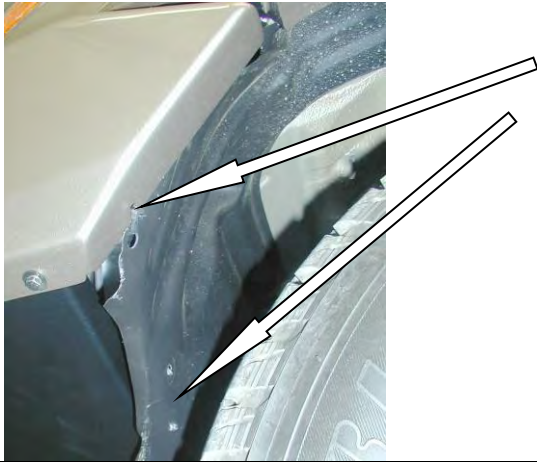

49. Cable tie the plastic wheel liner on the LH side of the vehicle to the two holes provided in the wing and the wing stone guard, as shown in the adjacent photo.



50. Mark lines along the inner guards using the bottom edge of the wing stone guards as a guide.

51. Remove the wing stone guards and cut along the lines marked in the previous step.

52. Refit the wing stone guards, tucking the inner guards inside the rear edge whilst fitting. Re-install all bolts from Step 48 and torque to specification.

 M6 - 9 Nm.

 M8 - 22 Nm.

 M12 - 77 Nm.

For Vehicles Manufactured

May 2006 and Onward: - The above two steps will need to be repeated on the Right Hand Side of the Vehicle also.



53. To install the number plate. Fit the plastic plugs into the square holes in the lower or upper pan depending on fitment. Fit the number plate to the bull bar using the black self-tapping screws.

The two photos display the number plate positions for both winch and non-winch bars.

BULLBAR FITMENT TO VEHICLE



54. If fitting optional driving lights to vehicle do so at this stage. Guide ratchet spanner between the upper and lower pans, as shown, to tighten the lights to the bar.



HIGH-LIFT JACKING POINTS



Provision for a high-lift jack is on both sides of bar.

ONCE BAR IS FITTED:

- ◆ Ensure all bolts are tensioned correctly
- ◆ All wiring is clear of sharp edges or moving surfaces and secured properly
- ◆ Piping is secured well away from sharp or moving components
- ◆ Check operation of winch if fitted
- ◆ Check all wiring and connections to turn signal lamps, sensors, headlamp washers etc. are functioning correctly

FINAL PRODUCT FITTED TO VEHICLE

