



FITTING INSTRUCTIONS

Part Number: **5236010-5136020-5136030-5136040**

Product

Description: Modular Bar

Suited to 2011-2014 F250, F350

vehicle/s: NOTE: If fitting these products to vehicles in Australia additional indicator and clearance lamps will need to be fitted to comply with ADRs

WARNING

REGARDING VEHICLES EQUIPPED WITH SRS AIRBAG:

When installed in accordance with these instructions, the front protection bar does not affect operation of the SRS airbag.

ALSO, NOTE THE FOLLOWING:

- ◆ This product must be installed exactly as per these instructions using only the hardware supplied.
- ◆ In the event of damage to any bull bar component, contact your nearest authorised ARB stockist. Repairs or modifications to the impact absorption system must not be attempted.
- ◆ Do not use this product for any vehicle make or model, other than those specified by ARB.
- ◆ Do not remove labels from this bull bar.
- ◆ This product or its fixing must not be modified in any way.
- ◆ The installation of this product may require the use of specialized tools and/or techniques
- ◆ It is recommended that this product is only installed by trained personnel
- ◆ These instructions are correct as at the publication date. ARB Corporation Ltd. cannot be held responsible for the impact of any changes subsequently made by the vehicle manufacturer
- ◆ During installation, it is the duty of the installer to check correct operation/clearances of all components
- ◆ Work safely at all times
- ◆ Unless otherwise instructed, tighten fasteners to specified torque

ARB 4x4 ACCESSORIES

Corporate Head Office

42-44 Garden St
Kilsyth, Victoria
AUSTRALIA 3137

Tel: +61 (3) 9761 6622
Fax: +61 (3) 9761 6807

Australian enquiries
North & South American enquiries
Other international enquiries

sales@arb.com.au
sales@arbusa.com
exports@arb.com.au

www.arb.com.au

GENERAL CARE AND MAINTENANCE

By choosing an ARB Bar, you have bought a product that is one of the most sought after 4WD products in the world. Your bar is a properly engineered, reliable, quality accessory that represents excellent value. To keep your bar in original condition it is important to care and maintain it following these recommendations:



- Prior to exposure to the weather your bar should be treated to a Carnauba based polish on all exposed surfaces. It is recommended that this is performed on a six monthly basis or following exposure to salt, mud, sand or other contaminants.
- As part of any Pre Trip Preparation, or on an annual basis, it is recommended that a thorough visual inspection of the bar is carried out, making sure that all bolts and other components are torqued to the correct specification. Also check that all wiring sheaths, connectors, and fittings are free of damage. Replace any components as necessary. This service can be performed by your local authorized ARB Stockist.

FITTING REQUIREMENTS

REQUIRED TOOLS FOR FITMENT OF PRODUCT:

METRIC SOCKET SET	METRIC RING AND OPENEDED SOCKET SET
ELECTRIC DRILL 13MM CAPACITY	6mm, 12MM DRILL BITS
RUST INHIBITING PAINT	PHILLIPS AND FLAT BLADE SCREW DRIVER
TAPE MEASURE	HYDRAULIC LIFTING PLATFORM OR ANOTHER PERSON.
SHARP CHISEL	TORQUE WRENCH

HAVE AVAILABLE THESE SAFETY ITEMS WHEN FITTING PRODUCT:

Protective eyewear		Hearing protection	
--------------------	---	--------------------	---

NOTE: 'WARNING' notes in the fitting procedure relate to OHS situations, where to avoid a potentially hazardous situation it is suggested that protective safety gear be worn or a safe work procedure be employed. If these notes and warnings are not heeded, injury may result.

FASTENER TORQUE SETTINGS:

SIZE	Torque Nm	Torque lbft
M6	9Nm	7lbft
M8	22Nm	16lbft
M10	44Nm	32lbft
M12	77Nm	57lbft

- ◆ ARB INTENSITY LIGHTS, UP TO 900 SERIES ROUND OR 800 RECTANGULAR DRIVING OR FOG LAMPS SUIT THIS PRODUCT
- ◆ BAR IS DESIGNED TO ACCOMMODATE WARN ZEON 12 AND WARN 16.5TI WINCHES

PARTS LISTING

APPLICATION	PART NO	QTY	DESCRIPTION	
CENTRE SECTION TO VEHICLE	180302	6	CABLE TIE 4.8 X 180 MM BLACK	
	3163073	2	PLUG BLANKING BLK 13MM (0-6.4MM PLTE)	
	3163091	4	PLUG BLANKING BLK 17mm (0-6.4mm PLATE)	
	3194586	6	PLATE PACKER	
	3194587	2	PLATE SHIM	
	3194602	2	PLATE WASHER TOP	
	3314919	1	PAN ASSEMBLY	
	3752000	1	BRACKET LICENSE PLATE	
	3759288	1	FAIRLEAD MOUNT	
	4581011	14	WASHER FLAT, M12 x 27 x 4	
	4581064	14	WASHER SPRING M12 TZP480	
	4581081	2	WASHER FLAT, M8 SS	
	4581094	2	WASHER SPRING M8 x 3/32 x 3/32 SS	
	4581304	8	WASHER FLAT, M6 SS	
	4584325	6	WASHER SPRING M8 x 3/32 x 3/32 BLACK	
	4584328	6	WASHER F M8 x 19 x 1.2 BLACK	
	5848404	11	PACKER MOUNT	
	5848405	2	PLATE WASHER SIDE	
	6151184	2	SOCKET HEAD CAS SCREW M8X1.25X30 SS	
	6151256	8	Screw M6x16 Button S/S	
	6151287	14	BOLT M12 x 1.75 x 60 Gd 8.8 ZP	
	6151321	7	NUT FLANGE M10 x 1.5 ZP	
	6151357	4	BOLT SEMS M10 X 30 ZP Gd 8.8	
	6151428	14	NUT FLANGE M12 X 1.75 ZP	
	6151542	3	SCREW SEMS M10 X 40 X 1.5 HX HD ZP	
	6151546	6	BOLT HXHD M8 x 1.25 x 25 GR8.8 BLACK	
	6151548	8	NUT FLANGE M8 x 1.25 GR8.8 BLACK	
	6151561	8	NUT FLANGE M6 x 1.0 BLACK	
	6522932	1	MESH ASSY	
	6522939	1	PANEL Cover	
	6821258	1	CONDUIT 13MM X 440MM	

APPLICATION	PART NO	QTY	DESCRIPTION
WINGS TO BULLBAR	3133027R	1	WING ASSY F TRUCK RIGHT
	3133027L	1	WING ASSY F TRUCK LEFT
	3500590	1	FOG LIGHT KIT
	3500640	1	FOG LIGHT ADAPTOR
	4581011	10	WASHER FLAT, M12 x 27 x 4
	6151480	10	NUT FLANGE M12 X 1.25 ZP
	6151321	8	NUT FLANGE M10 x 1.5 ZP
	6151357	8	BOLT SEMS M10 X 30 ZP Gd 8.8
	3163091	2	PLUG BLANKING BLK 17.4mm
	3751999R	1	BRKT WING MOUNT F TRUCK R
	3751999L	1	BRKT WING MOUNT F TRUCK L
	6151094	10	BOLT M12 x 1.25 x 30 Gd 8.8 ZP
	4581040	8	WASHER FLAT, M10 x 25 x 3 ZP
CENTER FRAME TO BULLBAR	6136362	1	FRAME ASSY F TRUCK
	3757060R	1	BRKT ASSY CENTRE FRAME F TRUCK RIGHT
	3757060L	1	BRKT ASSY CENTER FRAME F TRUCK LEFT
	3194558	2	PLATE UPRIGHT BOLTED
	6151255	4	BOLT M12 x 1.75 x 40 Gd 8.8 ZP
	4581064	4	WASHER SPRING M12 TZP480
	4581094	24	WASHER SPRING M8 x 3/32 x 3/32 SS
	4581011	4	WASHER FLAT, M12 x 27 x 4
	4581081	24	WASHER FLAT, M8 SS
	5811060	12	SLEEVE M8 THREAD F TRUCK
	6151263	24	SCREW M8 X 1.25 X 20 S/S SHCS
	6151671	4	SCREW M12x1.75x40 SHCS SS
	4584354	4	WASHER FLAT M12 SS
	4584355	4	WASHER SPRING M12 SS
OUTER FARMES TO BULLBAR	6131732R	1	FRAME ASSY OUTER F TRUCK RIGHT
	6131732L	1	FRAME ASSY OUTER F TRUCK LEFT
	4581011	2	WASHER FLAT, M12 x 27 x 4
	6151355	2	BOLT M12 x 1.75 x 30 Gd 8.8 ZP
	4581064	2	WASHER SPRING M12 TZP480

FITTING PROCEDURE



1. From behind the bumper un-plug and cut cables ties securing the fog light wiring loom



2. Remove three clips from bumper to release rubber guard. In the image one of the clip locations is shown.



3. Unbolt the bumper brace at the chassis end.



4. Remove four bolts (two on RH, two on LH tow hook) and 2 weld nut plates that connect tow hooks to bumper and put them to a secure location as they will be used later.
5. Slightly remove the bumper so that indicator loom can be removed in the next step.



6. Unclip indicator looms(if fitted) from both sides as shown.
7. Slide bumper off vehicle. Remove and keep the fog light wiring loom from bumper.



8. Remove tow hooks by unbolting 3 bolts from each side. Keep bolts as they will be used later.



9. Remove brackets that are attached to chassis from either side. Remove and discard any fasteners and captive locking washers.

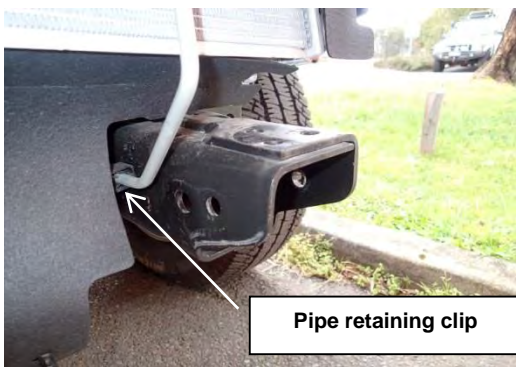

10. Detach the cooler line shown on the left from the clip and then remove the clip from the chassis. Make sure pipe is not damaged during this step.
11. Fit split conduit over cooler line.

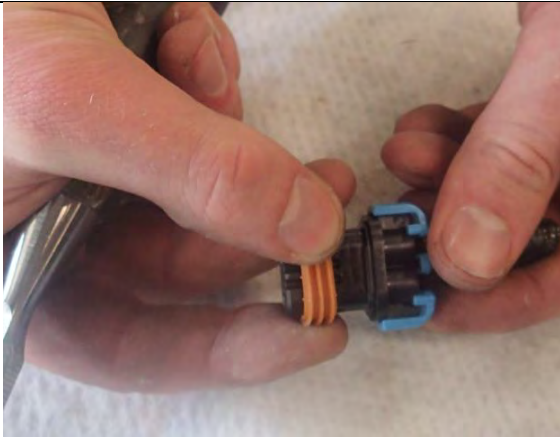

12. Remove fog light loom from O.E bumper.
Remove orange seal from the fog light end of the loom.
Using a sharp chisel, cut out rib from plug.
Place plug sideways on bench and slice out the rib as shown.
ALLWAYS CUT AWAY FROM YOUR HANDS
Check loom fits ARB Fog light plugs. If not more will need to be trimmed from rib.



Bar Assembly

Wing fitment

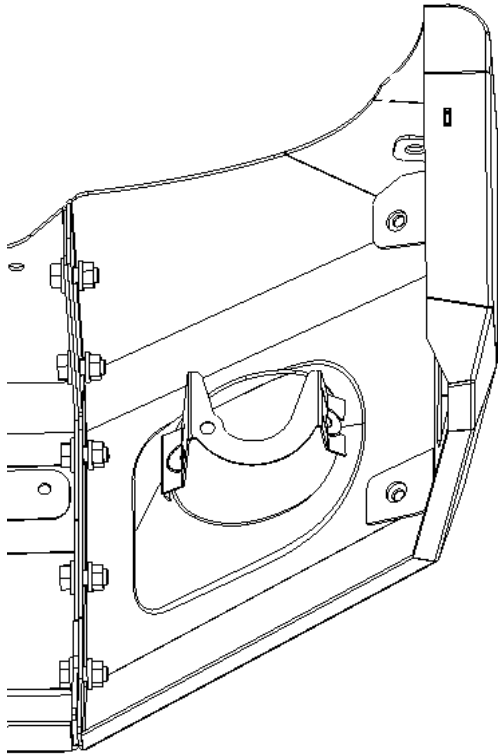

13. Fit each wing to bar using five sets of M12 x 35 fine thread bolts, M12 flat washers and M12 flange nuts. Align wings to centre section around the top and front face.



M12 - 77 Nm.

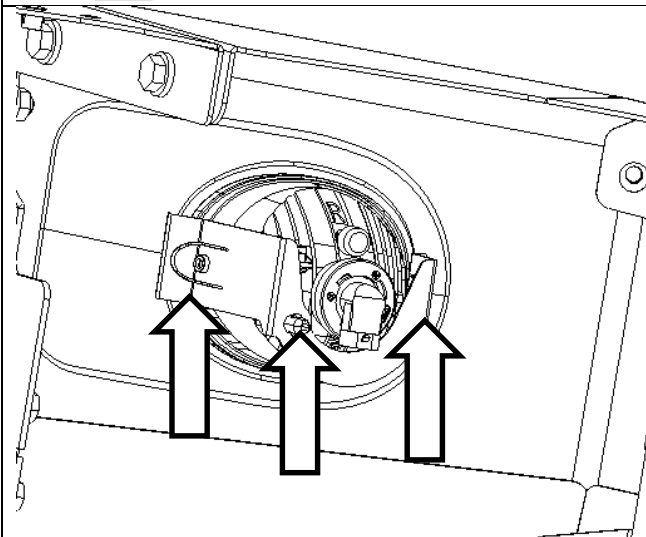

14. Slide fog lights into wings from the front and clip into position. RH side shown.

Fog light locates in 3 points shown.



15. Fit wing braces using 4 x M10 SEMS bolts ,8x M10 washers and 4x M10 flange nuts and tighten the bolts



M10 - 44 Nm.



16. Connect fog light loom to the fog light and secure loom to wing brace using cable ties through holes on the wing brace.

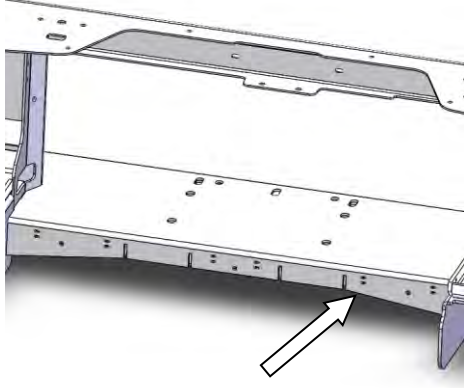

17. Attach the fog light loom to the bar using cable ties place through slotted holes.
18. Make sure that fog light wiring is secured from fog light to the vehicle all the way.

CENTRE FRAME FITTING PROCEDURE

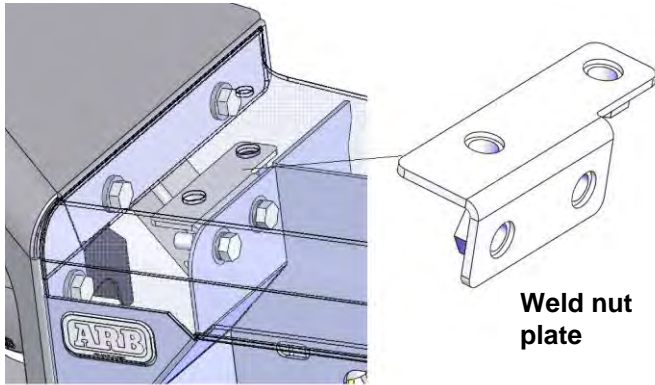

19. On Both sides, loosely fit weld nut plates to upright using 2 x M12 x 40 bolts, M12 spring washers and M12 flat washers, but do **not tighten**. Make sure that holes of top pan and weld nut plate are aligned.

Note that top pan is transparent in the picture for clarity.

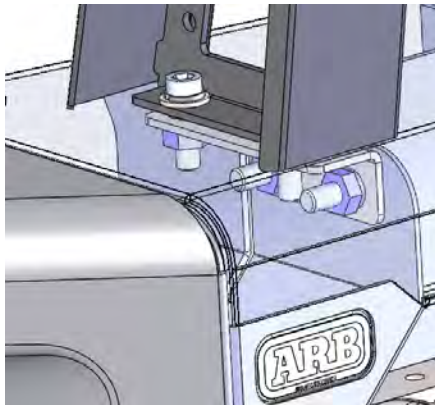

20. Loosely secure centre bar to top pan through weld nut plates from both sides using 4 x M12 x 40 socket head bolts, M12 spring washers and M12 flat washers. After alignment tighten all 8 bolts.

 M12 - 77 Nm

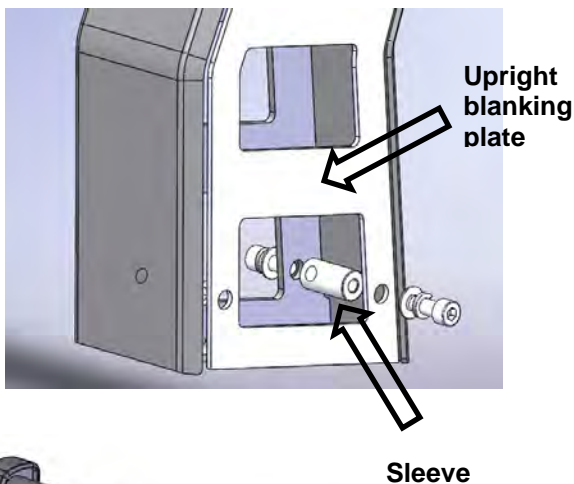

21. If outerframes are not fitted, fit blanking plates to uprights. M8 button head cap screws, stainless M8 spring washers and stainless M8 flat washers from either side.

 M8 - 22 Nm.

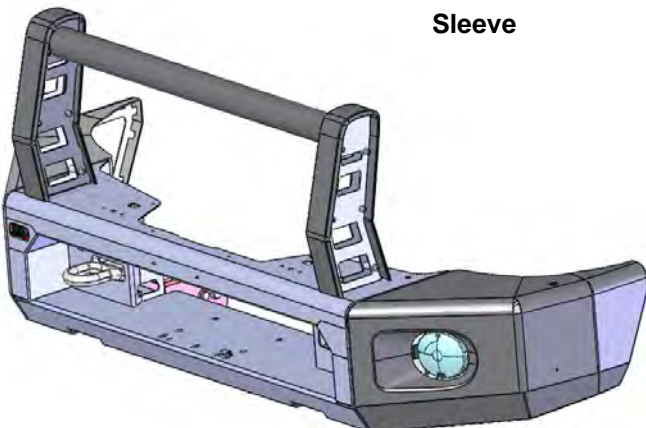

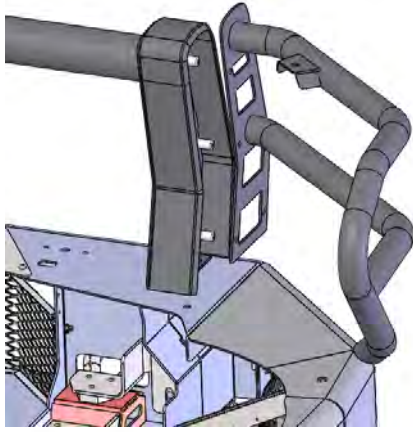

OUTER FRAMES FITTING PROCEDURE

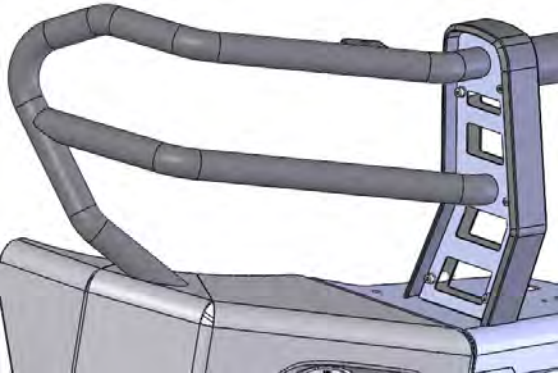

22. Remove upright blanking plates if fitted
23. Loosely secure outer section to wing using M12 x 35, M12 spring washer and M12 flat washer. **Do not tighten the bolts yet!**
24. Loosely secure outer frames to centre frame using:
M8 stainless socket head screws
M8 stainless flat washers
M8 stainless spring washers
25. Tighten all outer frame bolts



 M8 - 22 Nm.

 M12 - 44 Nm.

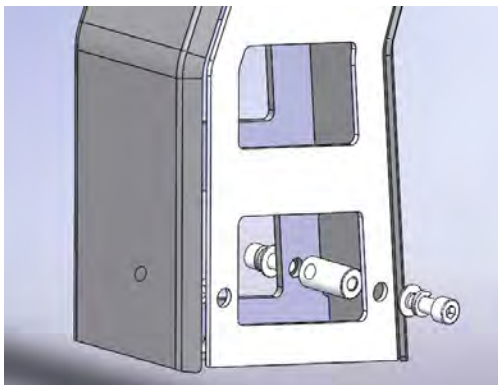

BAR ASSEMBLY

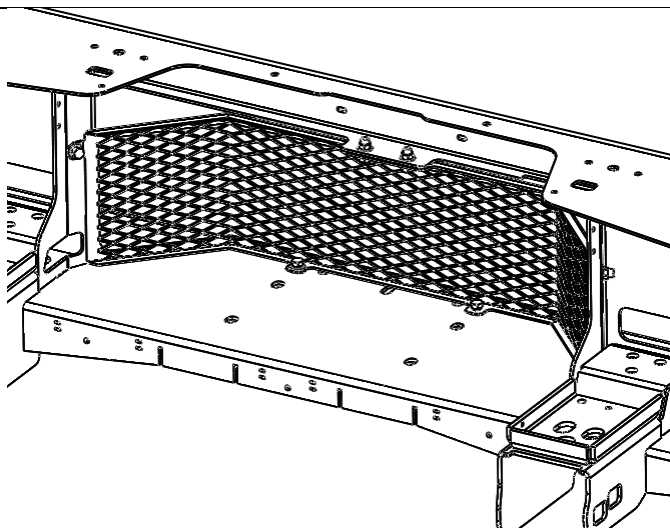

26. If no winch is fitted, attach mesh guard using six black M8 bolts, spring and flat washers and black M8 flange nuts.
Make sure that bolts on lower pan connection are torqued first.

 M8 - 22 Nm.

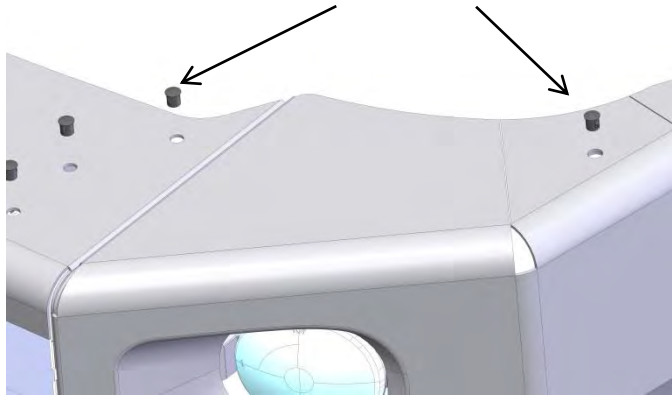

27. If centre frame or outer frame kits were not installed, place plastic plugs supplied on holes on top of bar as shown.

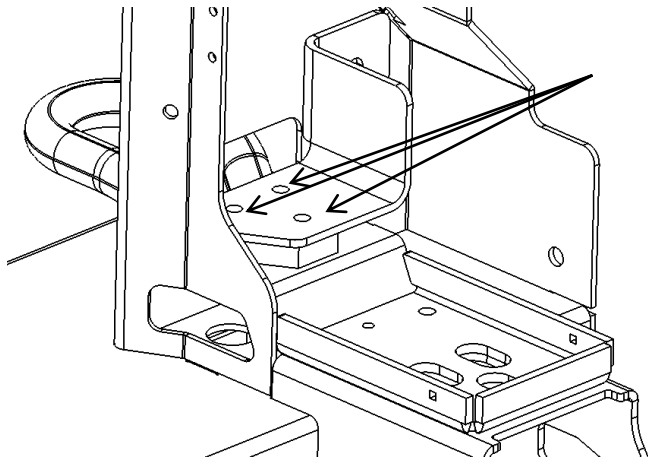

28. Fit tow hooks to bar using original fasteners and nut plates.

Tighten all bolts down evenly and ensure all parts are sitting correctly.

Fully torque bolts.

 **M12 - 77 Nm.**

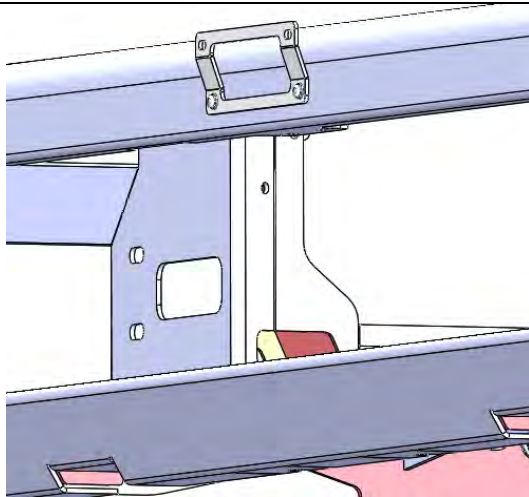

29. If no winch is fitted secure license plate directly to bar using M6 dome head stainless steel screws, flange nuts and SS flat washers.

30. For vehicle with winch, fit license plate bracket shown. Also using M6 dome head stainless steel screws, flange nuts and SS flat washers.

 **M6 - 9 Nm.**

WINCH FITTMENT

This bull bar has been designed to fit Warn Zeon and Warn 16500lb winches. No supplementary parts are required for fitment of these winches.

It is important that a winch of capacity greater than 16500lb is not fitted even if it physically fits into the bar.

Unless otherwise is stated, fasteners used during fitment of winch are supplied with bull bar centre pan fitting kit.

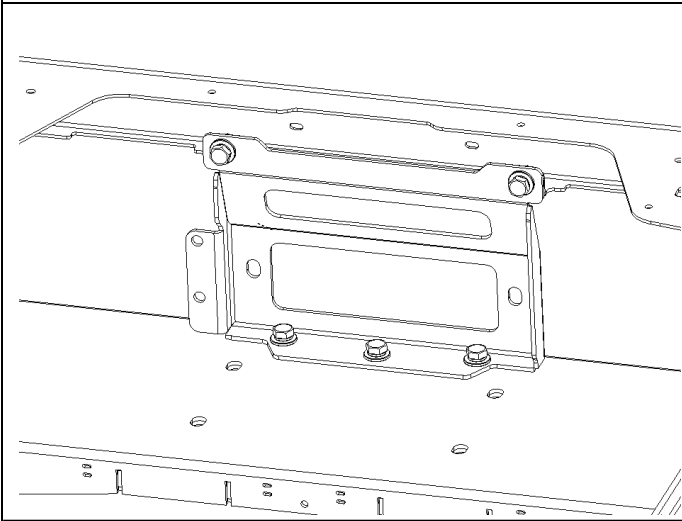

31. Fit fairlead bracket as shown

Use:

2 of M10x30 SEMS bolts and flange nuts on the upper holes.

3 of M10x40 SEMS bolts and flange nuts on the lower holes

 M10 - 44 Nm

32. Secure fairlead to fairlead mount bracket using 2x M10x30 SEMS bolts and flange nuts

 M10 - 44 Nm

If fitting warn 16.5 winch, fit control box as shown using the stainless M8 x30 caps screws, flat washers, spring washers and black M8 flange nuts

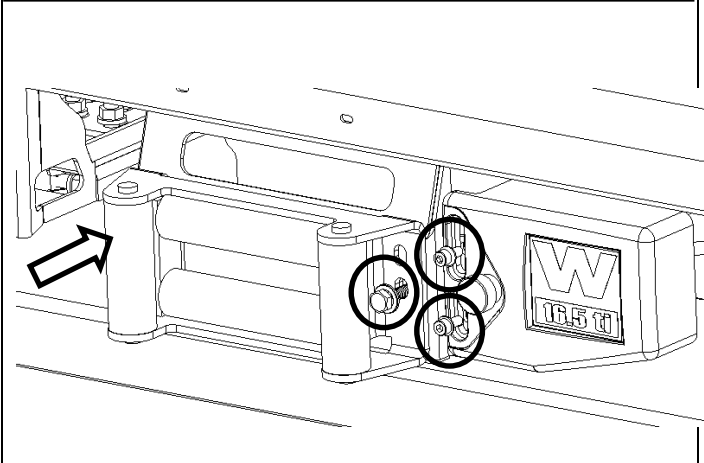

33. Fit the winch to the lower pan.

If fitting Zeon winch, use 4 M10x50mm bolts and nuts from warn fitting kit.

If fitting warn 16.5 use 7/16 x1 1/2" bolts from warn fitting kit

 M10 - 44 Nm  7/16- 55ft.lbs

Wire up winch as per winch fitting instructions.

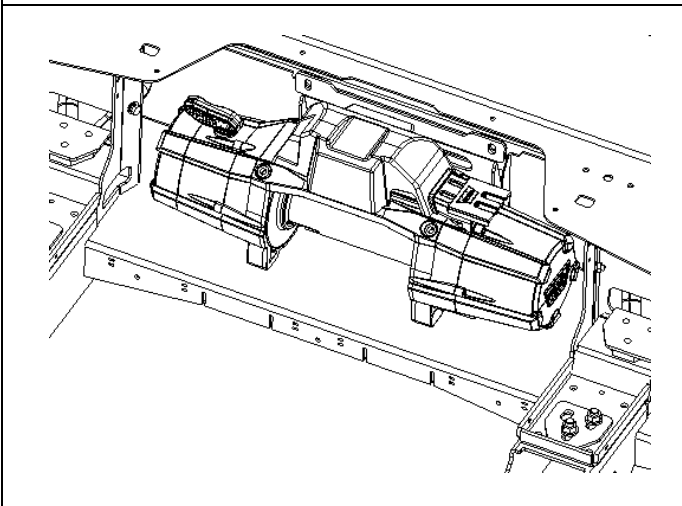

Fitment to vehicle.

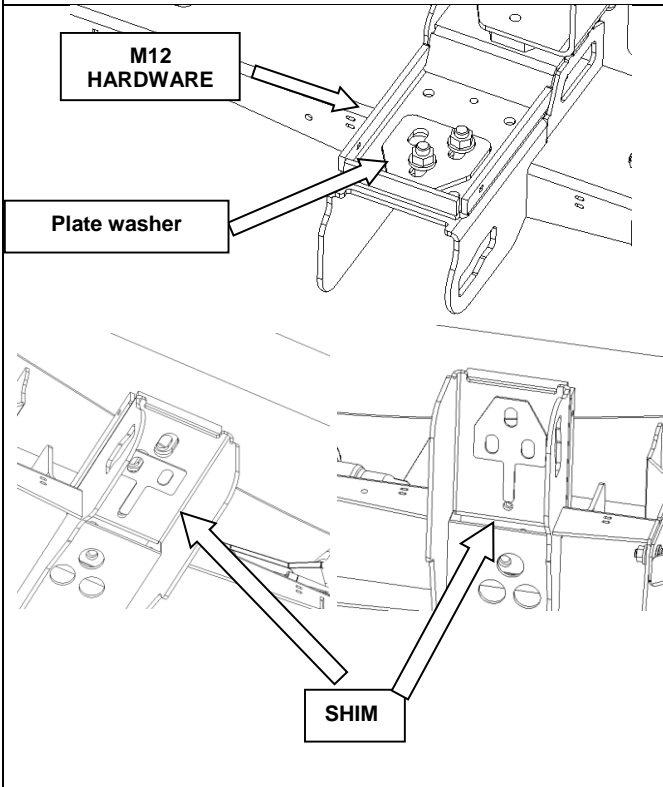

34. With the assistance of another person or a hydraulic lift table gently slide the bar onto the vehicle making sure not to damage any vehicle components.
35. **Loosely** secure the bar to top of chassis rail using plate washer and 2 x M12 x 60 bolts, spring and flat washers and M12 flange nuts, **do not** tighten bolts.
36. Repeat previous step for other side mounting bracket.
37. Align the wings to the front fenders
Check angle of the bar relative to the guards.
Tilt the bar upwards using the 2 hole shims or lift the bar up by using the 3 hole shims.
These shims can be slid in by loosening the mount holes and tilting bar backwards.
If good alignment cannot be achieved loosening and re adjusting the wings may be required.

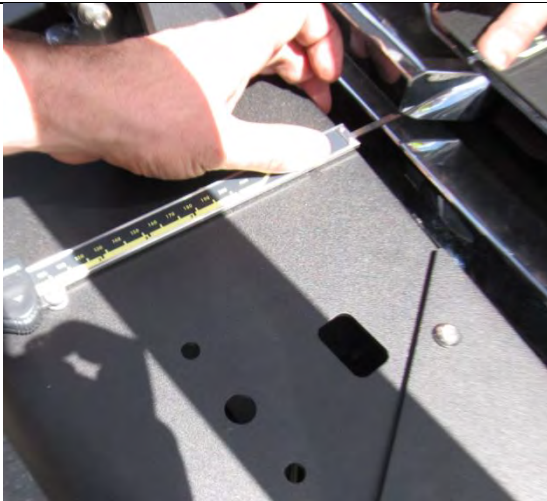

38. Align the bar in front/back direction such that clearance between top pan of the bull bar and grill is around 30-35 mm along the grill.
39. Ensure clearance to winch (if fitted) is at least 30mm. if not trim lower portion of grill.
40. Once sideways and front/back alignments are fully satisfied tighten the four mount bolts.
Re check alignment after bar is tightened. If bar has moved loosen bolts and re align.

 M12 - 77 Nm.

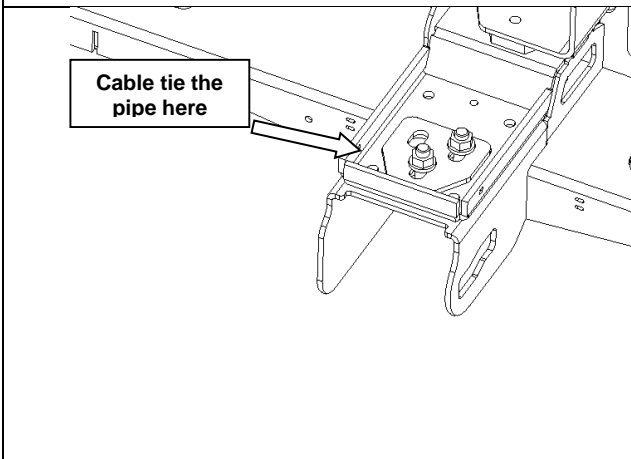

41. Cable tie the pipe detached at step 10 to mounting bracket hole shown in the image.

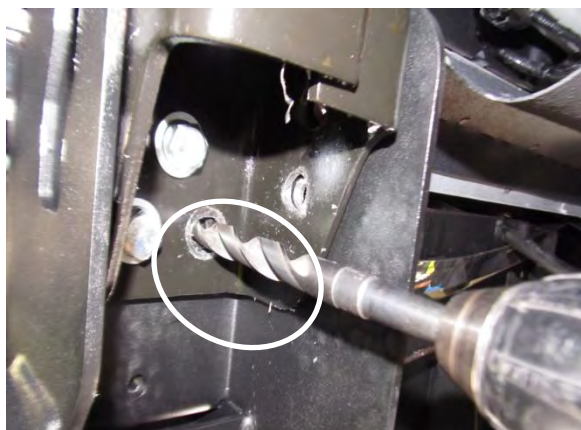
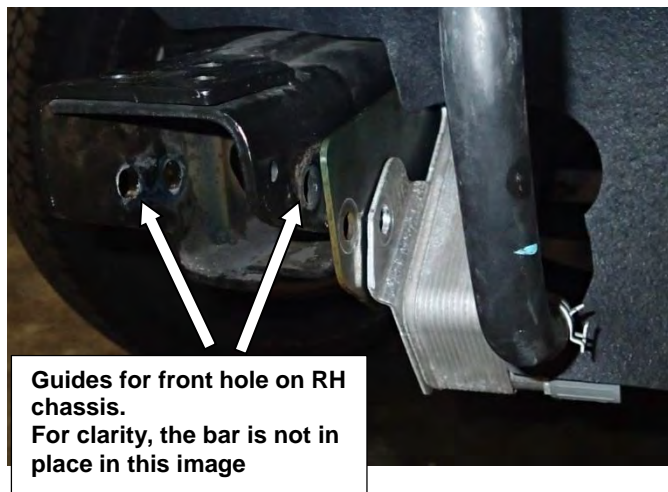
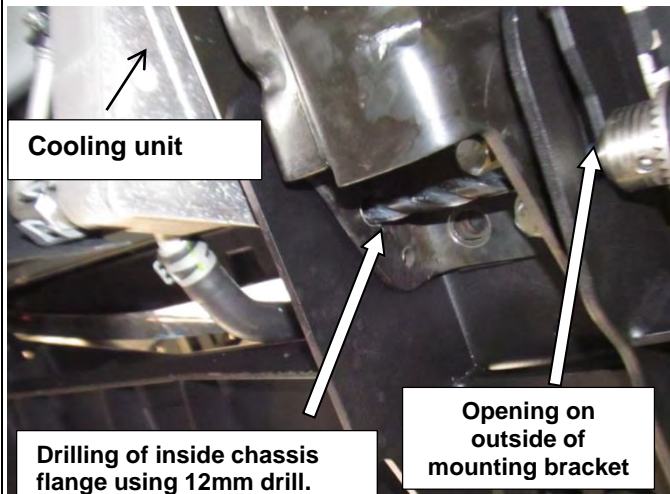

42. Once satisfied with the adjustment of the bar. Drill the pinning bolt locations in the sides of the mount brackets

With a Ø12mm bit, drill through the inner flange of the mount face of the bullbar using the chassis holes as a guide

The drill needs to pass through the outside chassis holes.

4 holes in total are to be drilled, 2 on each side.

Hint: For easier drilling, mark the centre of the hole with the 12mm bit, drill the hole with a 6mm bit then enlarge the hole with the 12mm bit

During this drilling process make sure that chassis holes and cooling unit system holes are aligned. Be careful not to drill into the cooling unit.



Warning: Drilling operations can result in flying metal debris, safety glasses should be worn.

43. Drill the pinning bolt locations in the top face of the mount brackets. Use the remaining upper chassis hole as a guide, drill through the top face of the mount bracket.

Hint: For easier drilling, mark the centre of the hole with the 12mm bit, drill the hole with a 6mm bit then enlarge the hole with the 12mm bit



Warning: Drilling operations can result in flying metal debris, safety glasses should be worn.

44. Apply rust inhibiting paint around drilled holes.
45. Insert set of M12 x 60 bolt, spring washer, two flat washers and flange nut into holes drilled in holes in top face of chassis.

 **M12 - 77 Nm.**

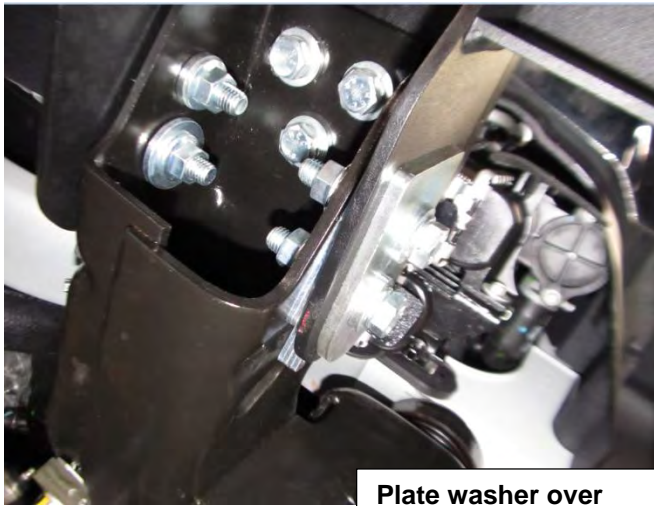
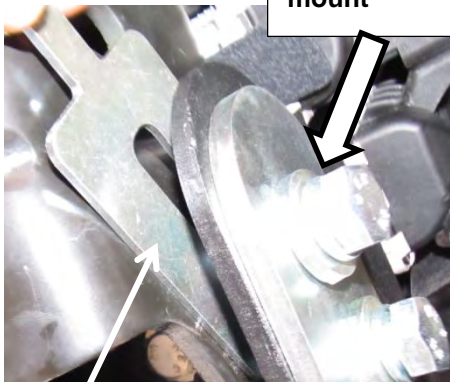

Plate washer over large slot on outside mount



Fill any gaps between chassis and bar mount with packers before tightening bolts



LH chassis connection looking from wing

46. Insert 8 sets of M12 x 60 bolts, spring washers, flat washers and flange nut to holes drilled in side of chassis. On the outside face, the plate washer is used over the large slot in the mounts. Do not tighten bolts.

Note: If transmission cooler is in place, a bolt will also pass through its mounting plate.

47. Insert packers between mounting bracket and chassis face if there is a gap big enough to insert packers. Tighten all bolts.

 M12 - 77 Nm.

48. Plug in and test fog lights.

49. If not fitting a winch, fit panel to top face on bull bar using 4 x M6 dome head stainless steel screws, flange nuts and SS flat washers.

Nuts on underside can be accessed via the holes at the corners of the mesh grill under the upper pan.

 M6 - 9 Nm.



FITTED PRODUCT

