



**MAXIMUM PERFORMANCE
PORTABLE AIR SUPPLY
*OPERATION GUIDE***



CKMTP12

Part No. 2102MTP12
Revision Date 28/02/2020
Copyright © 2013 by ARB Corporation Limited

No liability is assumed for damages resulting in the use of the information contained herein. ARB Air Locker Air Operated Locking Differentials, ARB Air Locker Air Activation System and Air Locker are trademarks of ARB Corporation Limited. Other product names used herein are for identification purposes only and may be trademarks of their respective owners.



EC Declaration of Conformity

This declaration of conformity is issued under the sole responsibility of the manufacturer. This declaration relates to these products:
CKMTP12

The products are in conformity with the following standards or standardized documents:
EN 55014-1 : 2003 (AS/NZS CISPR 14.1)
EN 55014-2 : 2003 (AS/NZS CISPR 14.2)

According to the provisions of the directives:
2004/108/EC (EMC directive).

Technical file at:
ARB Corporation Ltd, 42-44 Garden St, Kilsyth, Victoria, Australia.

Signed for and on behalf of ARB Corporation Ltd

A handwritten signature in black ink, appearing to read 'Andrew Brown', is written over a horizontal line.

Andrew Brown
Managing Director
Melbourne, March 2016

ARB 4x4 ACCESSORIES

Corporate Head Office

42-44 Garden St
Kilsyth, Victoria
AUSTRALIA
3137

Tel: +61 (3) 9761 6622
Fax: +61 (3) 9761 6807

Australian enquiries
North and South American enquiries
Other international enquiries

sales@arb.com.au
sales@arb.com.au
exports@arb.com.au

www.arb.com.au

Table of Contents:

| | | |
|----------|---|-----------|
| 1 | Introduction | 2 |
| 1.1 | Features Of The CKMTP12 Portable Compressor | 2 |
| 1.2 | What Is Included | 3 |
| 1.3 | Specifications Of The CKMTP12 Portable Compressor | 4 |
| 2 | Safe Air Compressor Operation | 5 |
| 2.1 | Safety Precautions | 5 |
| 2.2 | Connecting For Use | 7 |
| 2.3 | Tyre Filling | 9 |
| 2.4 | Air Powered Tools | 10 |
| 2.5 | Keeping The Carry Case Organised | 11 |
| 2.6 | Understanding The Built-In Protection Devices | 12 |
| 3 | Service & Maintenance | 13 |
| 3.1 | Air Filter Service | 13 |
| 3.2 | Fuse And Wiring Loom Replacement | 14 |
| 3.3 | Draining Moisture From The Air Tank | 14 |
| 4 | Parts List | 15 |
| 4.1 | Exploded Diagram | 15 |
| 4.2 | Itemized Parts List | 16 |

1 Introduction

IMPORTANT :

To get the safest and most effective service from this portable air compressor, please read this guide in its entirety before attempting to use the compressor.

1.1 Features Of The CKMTP12 Portable Compressor

The ARB CKMTP12 portable air compressor is a compact sized yet high performance compressed air source that is intended for rapid inflation of large tyres and operation of most air powered tools rated up to 85LPM [3CFM] @ 600kPa [90PSI].

The ARB CKMTP12 is a world class recreational product designed and built to commercial / industrial standards boasting the following features:

- Ultra compact twin motor, dual cylinder design makes this the highest flowing portable compressor of its size on the market at 174LPM [6.16CFM]
- Integrated aluminium air tank and pressure switch regulates pressure between 930kPa [135PSI] and 1030kPa [150PSI] suited to most air powered tools.
- Mounted in a waterproof carry case constructed from a durable impact resistant polymer. The carry case has convenient compartments for storing the air hose and other compressor accessories.
- Ducted IP55 sealed brushed DC cooling fan and anodized aluminium motor mounting brackets effectively dissipate heat from the motors, heads and electronics allowing for a 100% duty cycle (under room temperature conditions).
- Engineered, built and individually dyno-tested in Australia from local and important components.
- Fully serviceable and all replacement parts available.
- Constructed primarily of light weight, high strength engineering grade materials, including military and aerospace standard components.
- Hard-anodized cylinder bores and PTFE (Teflon) impregnated carbon fiber piston seals for reduced friction and maximum trouble free life.
- Built with sealed components for moisture and dust resistance.
- Motors are 100% ball bearing equipped, and feature a unique linear brush pre-load system for extra long life, low heat and quiet operation throughout the life of the unit.
- Compressor pistons are equipped with high shock rated roller bearing.
- High density and high flow washable sintered bronze air filter element.
- Motors are thermal cut-out protected against damage caused by extreme temperature use.

1 Introduction

- Pressure switch and relay equipped electrical system prevents run-on when not filling, or any damage to compressor or hoses as a result of the pressure generated from a kinked air line.
- Illuminated isolating switch is easy to see at night, and protects the user from hazardous sparking when connecting the alligator clips to the battery terminals.
- Equipped with dual heavy duty Maxi-Fuses for professional in-line circuit protection and true circuit redundancy in case of a fault.
- Over-pressure safety valve equipped as a back-up protection from either pressure switch failure, thermal over pressure generated in a hot vehicle (i.e., no need to drain pressure when finished use.), or accidental connection to an external high pressure source.

1.2 What Is Included

Below is a detailed list of items included with this kit:

- Fully assembled and performance tested air compressor and air tank mounted into a water proof carry case.
- Canvas compartment for storing air hose and compressor accessories.
- OEM quality illuminated compressor isolating switch.
- High quality wiring loom with automotive grade alligator clamp type battery contacts, and a pressure switch driven automotive relay control circuit.
- Two splash resistant air filters with washable high-flow sintered bronze filter cartridges.
- 6 meter [20 ft] long high quality abrasion and heat resistant air hose with male to female couplings.
- Hose couplings are specially designed corrosion resistant, one-handed (push-lock) quick connect type to suit US industrial standard air fittings (Ref: compatible types Section 1.3).
- Air blow gun with US industrial standard male air fitting.
- Inflation accessories kit including high-flow tyre filler attachment (US industrial standard) with integral stop-valve, a Schrader valve to US industrial standard adaptor, and extra nozzle attachments for inflating items such as sports balls, air mattresses, etc.

1 Introduction

1.3 Specifications Of The CKMTP12 Portable Compressor

| GENERAL SPECS | | METRIC | | IMPERIAL | |
|-------------------------------|---------|-----------------|-------|----------------|--------|
| SUPPLY VOLTAGE | 12 | Volts DC | 12 | Volts DC | |
| MAX CURRENT DRAW (each motor) | 34.3 | Amps @ 1030 kPa | 34.3 | Amps @ 150 PSI | |
| MAX CURRENT DRAW (total) | 68.6 | Amps @ 1030 kPa | 68.6 | Amps @ 150 PSI | |
| FUSE RATING (each motor) | 40 | Amps | 40 | Amps | |
| RELAY RATING (each motor) | 40 | Amps | 40 | Amps | |
| WEIGHT (total kit) | 15 | kgs | 33 | lbs | |
| DIMENSIONS | -LENGTH | 478 | mm | 18.8 | inches |
| | -WIDTH | 355 | mm | 14.0 | inches |
| | -HEIGHT | 186 | mm | 7.3 | inches |
| DUTY CYCLE @ 22°C [72°F] | 100 | % | 60 | mins. per hour | |
| PRESSURE SWITCH CLOSED | < 930 | kPa | < 135 | PSI | |
| PRESSURE SWITCH OPEN | > 1030 | kPa | > 150 | PSI | |
| SAFETY VALVE PRESSURE | > 1240 | kPa | > 180 | PSI | |
| MOTOR THERMAL CUT-OUT | 115 | degrees C | 239 | degrees F | |
| MAX. AMBIENT TEMPERATURE | 100 | degrees C | 212 | degrees F | |

| SPECS @ NO LOAD | METRIC @ 0 kPa | | IMPERIAL @ 0 PSI | |
|-----------------|----------------|--------|------------------|------|
| CURRENT DRAW | 28.4 | Amps | 28.4 | Amps |
| AIR FLOW RATE | 174.4 | L/min. | 6.16 | CFM |

| SPECS @ TYRE PRESSURE | METRIC @ 200 kPa | | IMPERIAL @ 29 PSI | |
|-----------------------|------------------|--------|-------------------|------|
| CURRENT DRAW | 50.4 | Amps | 50.4 | Amps |
| AIR FLOW RATE | 131.8 | L/min. | 4.68 | CFM |

NOTE: The specifications above were recorded under laboratory conditions at 22°C [72°F].

| EXTERNAL CONNECTIONS SPECS | |
|---|---|
| AIR INTAKE THREADS (female) | 1/4-18 NPSC (parallel pipe thread) |
| AIR FILTER THREAD (male) | 1/4-18 NPT (tapered pipe thread) |
| PRESSURE SWITCH THREAD | 1/4-18 NPT (tapered pipe thread) |
| SAFETY VALVE PORT THREAD | 1/8 BSPP (parallel pipe thread) |
| MANIFOLD OUTLET THREAD | 1/4-18 NPT (tapered pipe thread) |
| STAINLESS BRAIDED HOSES | JIC-4 [AN-4] |
| AIR COUPLING FITTING TYPE (international equivalent standards) | 'US Industrial Standard' ISO 6150 B Rectus series 23/24/1400 Tema series 1400 Legris series 23 DYNAQUIP D3 CEJN 310 US.MIL.C 4109 Norma / AFNOR: NF.E49.053 Parker series 30-1/4" and 20-1/4" Aignep 220 Hansen series 3000 Norgren series 237 Gromelle series 600 |

WARRANTY

This ARB Air Compressor is designed to provide many years of trouble free recreational use, and is warranted to be free from manufacturing defects for two (2) years from the date of purchase.



2 Safe Air Compressor Operation

2.1 Safety Precautions

Please carefully read and always abide by each of the following points when using a portable air compressor.

HINT : Place a ✓ mark inside each of the symbols to ensure you have read and understood all of the safety precautions.



2.1.1 Electrical Safety

- Never make connections to the battery with the compressor isolating switch turned 'ON' as the resulting sparking at the battery terminals could pose a fire hazard.



2.1.2 Compressed Air Safety

- Wear suitable protective equipment (e.g., glasses, face shields, etc.) to control the risk of injury due to projectile particles.
- Never point the hose at anyone and always see that bystanders are out of the line of air flow.
- Never attempt to stop or slow the flow of compressed air using direct exposure to skin.

NOTE : Normal textile clothing does not protect the skin against the risk of air embolism posed by exposure to compressed air.

NOTE : An air embolism is a serious condition of the blood stream which may result in severe injury or death.

- For the same reason as above, never use compressed air to clean clothing, hair or body.
- Disconnecting hoses or other accessories from a compressed air system can result in projectiles. To avoid projectiles either hold the item being disconnected securely or switch off the compressor and evacuate all compressed air from the system.
- If using compressed air accessories (e.g., extension or replacement hoses, or pneumatic devices like air tools) other than genuine ARB, avoid the danger of spontaneous disconnection by using only products with hose fittings that conform to one of the international standards listed in the specifications (ref: Section 1.3).

2 Safe Air Compressor Operation

- If using extension or replacement hoses other than genuine ARB hoses, use only sound strong hose with secure couplings and connections having a high temperature rating and a maximum pressure rating of over 1380 kPa [200 PSI].
- Air hoses should be securely held to prevent whipping.
- Compressed air contains contaminants which makes it unsuitable for use in air-supplied respiratory protective devices such as spray painting masks. Only use compressed air with such devices when appropriately filtered through approved filtration equipment.



2.1.3 Pressure Vessel Safety

- The ARB CKMTP12 contains two mechanical pressure relief valves that will bleed of pressure the system above 1100kPa [160PSI].
- The air tank contains compressed air and could result in an explosion if punctured. Avoid impacting the air tank with anything that could cause a puncture.
- If the air tank is damaged in any way it should be replaced immediately.



2.1.4 High Temperature Safety

- The compressor, hoses and fittings may become hot after an extended period of use. Caution must be exercised to avoid handling the hot surfaces.

2 Safe Air Compressor Operation

2.2 Connecting For Use

- Position the compressor on a sturdy flat surface before opening the box.
- Unlock and open the box using the two latches.
- Make sure that the switch is in the 'OFF' position by pressing down on the top of the switch rocker.



- Uncoil the power lead and connect the positive (+) alligator clamp (RED handle) directly to the positive (+) terminal of the vehicle's 12 volt battery.
- Connect the negative (-) alligator clamp (BLACK handle) directly to the negative (-) terminal of the vehicle's 12 volt battery.

NOTE : The switch should now be illuminated telling you that the compressor has been connected to power. But the compressor will not start until the switch rocker is pressed on the bottom.

- Attach the air hose to the compressor by inserting the male end of the hose into the hose coupling on the compressor and simply pressing inward until the coupling sleeve clicks forward. The sleeve of the coupling does not need to be pulled back by hand at all.
- Attach the compressed air accessory to the opposite end of the hose in the same way.
- Press the bottom of the rocker switch down to start the compressor and pressurize the air tank and hose.
- The compressor will automatically stop when the pressure in the system reaches the pre-set pressure switch 'OFF pressure' of 1030kPa [150PSI].

2 Safe Air Compressor Operation

NOTE : Once compressed air has been expelled through the attached device (e.g., tyre filler, air tool, etc.) and the pressure in the system reduces the pre-set pressure switch 'ON pressure' of 930kPa [135PSI] then the compressor will automatically start running again.

IMPORTANT :

When accessories such as the hose are connected to the compressor they will contain compressed air. As such care must be taken when they are disconnected from the compressor to avoid projectiles.

- To disconnect the air hose from the compressor, hold the hose coupling grip between your thumb and forefinger as shown, then press the hose coupling down. Make sure to securely hold the hose grip with the remaining fingers on your hand to control the hose release when pressurized.



2 Safe Air Compressor Operation

2.3 Tyre Filling

- With the compressor connected and switched on as described in Section 2.2, connect the ARB tyre filler (supplied) to the air hose coupling by inserting it into the coupling and simply pressing inward until the coupling sleeve clicks forward. The sleeve of the coupling does not need to be pulled back by hand at all.

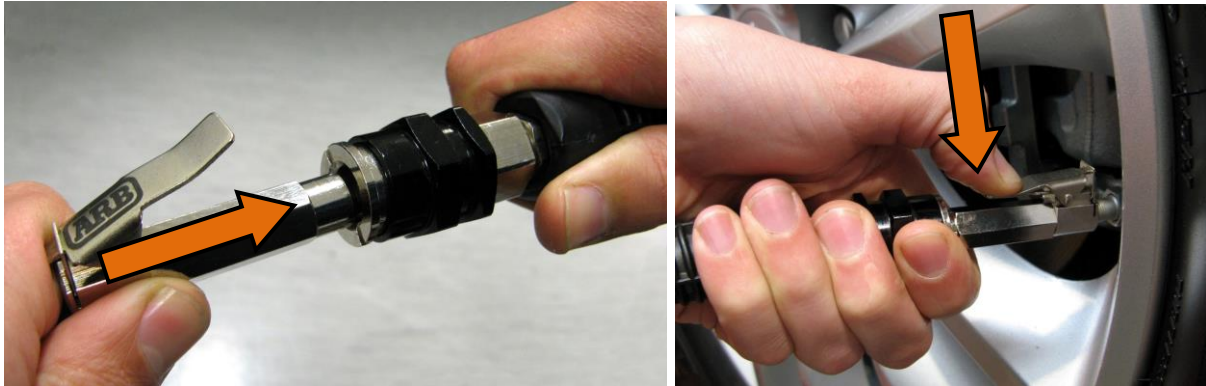

NOTE : ARB's tyre filler attachment is equipped with a stop valve. Air will not pass through the tyre filler attachment until it is connected to a tyre valve.

NOTE : To get maximum performance out of the compressor and to avoid depleting your vehicle's battery it is highly recommended to leave the vehicle running at idle.

- Attach the ARB tyre filler to any standard tyre valve by depressing the lever on the filler and then pushing the filler onto the tyre valve until a good seal is made.

NOTE : Once air has passed through the filler and the pressure in the air tank reduces the compressor should automatically start.

- To keep air flowing without holding the filler simply release the lever on the filler while still holding the filler onto the tyre valve and then let go of the filler.
- To stop filling and remove the filler from the valve depress the lever on the filler and pull the filler away from the tyre valve.

NOTE : Periodically disconnect the filler and check the tyre pressure with an automotive tyre pressure gauge.

IMPORTANT :

Do not fill your tyres over the manufacturer's specified maximum pressure rating.

2 Safe Air Compressor Operation

2.4 Air Powered Tools

In addition to tyre inflation the ARB CKMTP12 is suitable for operating most air powered tools, some of which are shown below.

- With the compressor connected and switched on as described in Section 2.2, connect the air tool to the air hose coupling by inserting it into the coupling and simply pressing inward until the coupling sleeve clicks forward. The sleeve of the coupling does not need to be pulled back by hand at all.
- The ARB CKMTP12 will continuously run air tools which require up to 85LPM [3CFM] @ 600kPa [90PSI]. For maximum power output from your air tool allow the compressor to fill the air tank to maximum pressure before operating and in between uses.



2 Safe Air Compressor Operation

2.5 Keeping The Carry Case Organised

The ARB CKMTP12 packs a lot of gear into a purpose built carry case. The compressor carry case has been designed with designated storage compartments for the accessories to help keep things organised. The wiring loom has also been configured with the black wire longer than the red to allow it to pack away as neatly as possible. The picture below shows the intended layout for organising the carry case in the most effective way.



2 Safe Air Compressor Operation

2.6 Understanding The Built-In Protection Devices

This compressor has been equipped with both THERMAL and OVER PRESSURE protection devices in the interests of personal safety and to protect the unit from unnecessary internal damage.

NOTE : Never disable or modify any of the compressor's built-in protection devices.

2.6.1 Thermal Cutout Switch

The process of compressing air is a natural generator of heat. This heat generation is increased accordingly by increasing the compressed air flow rate or increasing the pressure level of the air flow.

The large DC electric motor inside the compressor is also a source of heat which increases with the amount of work being done by it.

The compressor has been designed to naturally disperse this heat into the air around it, however, the ambient temperature outside will have an effect on how fast this heat can be dispersed. If excessive levels of heat are allowed to build up inside the compressor the unit may be put at risk of internal damage. For this reason an internal electric switch has been designed into the back of each motor which will simply turn the compressor off if the temperature approaches a dangerous level, and will automatically reset and turn the compressor back on once the unit has cooled down to a safe temperature. This off time may last anywhere from just a few minutes up to half an hour depending on conditions around the compressor.

2.6.2 Over Pressure Safety Valve

This compressor is equipped with a pressure operated electric switch which has been factory set to turn off the compressor at a safe level of pressure, and then turn it back on again once the pressure has been exhausted down to a lower level. Should this switch fail for any reason the compressor is capable of producing pressure well beyond its safe shut off limit.

A compressor which has reached its safe pressure maximum that has been left in direct sun or inside a hot vehicle may build up additional pressure past the safe working level.

Connecting your compressor up to any air system which might already contain a residual pressure that is higher than the compressor's safe pressure limit may raise the internal pressure of the compressor past the safe pressure limit.

This compressor is equipped with a mechanical over pressure safety valve which has been factory set to bleed off to atmosphere any excessive pressure build up (i.e., from any of the situations above) before it can pose any personal danger or cause damage to compressor components.

3 Service & Maintenance

3.1 Air Filter Service

The ARB CKMPT12 comes factory fitted with high density, high flow, sintered bronze air filters to protect the compressor components, and any accessories that might be used with the compressor, from damage caused by the ingress of dirt and fine dust particles. The filter element is removable and cleanable and should provide for years of continuous service.

Follow the steps below to disassemble, clean and re-assemble the air filter.

- Unscrew the air filters from the compressor.
- Remove the air filter cover from the air filter base by applying slight prying pressure under the fingers of the cover.
- Remove the filter element disk.
- Vigorously wash the element in a solution of hot soapy water.
- Rinse the element in pure hot water.
- Dry thoroughly.
- Insert the element back into the air filter base making sure that the flattest face of the disk faces toward the filter base.
- Snap the air filter cover back onto the base and rotate the cover into the desired position.
- Install the air filters back into the compressor.

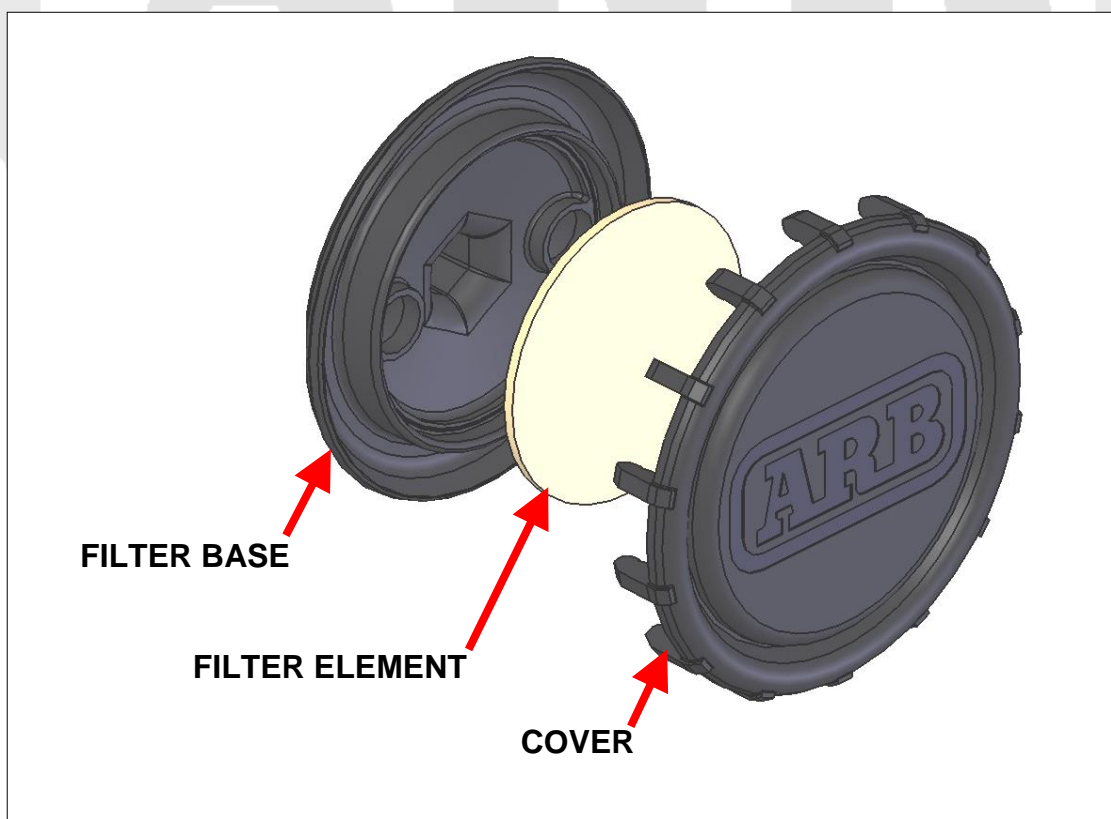

3 Service & Maintenance

3.2 Fuse And Wiring Loom Replacement

The CKMTP12 supply wiring loom is connected to the compressor by a sealed high current rated connector. Should the loom or battery clamps be damaged and need replacement the supply loom can simply be unplugged and replaced.

The supply wiring loom contains two inline fuses near the battery end of the positive (+, RED) wire providing independent circuit protection for each motor. If either of the fuses requires replacing, they can be removed by opening the black rubber fuse housing cover and pulling straight outward on the fuse until it slides free of the fuse block. The fuse should only be replaced with a fuse of the same type (maxi blade type) and of the same amp rating (40A) or less.

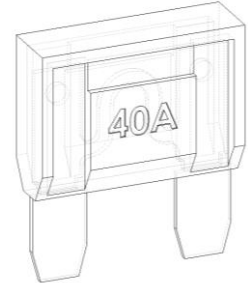

3.3 Draining Moisture From The Air Tank

After prolonged compressor use moisture can accumulate in the air tank and as a result the air tank should be drained after approximately 10-20 hours of compressor run time. The air tank can be drained as follows:

- With the compressor connected and switched on as described in Section 2.2, connect the air blow gun to the air hose.
- Lift the compressor carry case off the ground by the handle, leaving the lid open.
- Operate the blow gun with the nozzle pointing towards the ground and away from people. Press the blow gun trigger and the accumulated moisture in the air tank will be expelled through the blow gun.

4 Parts List

CKMTP12

Portable Compressor Kit – Exploded Parts Diagram

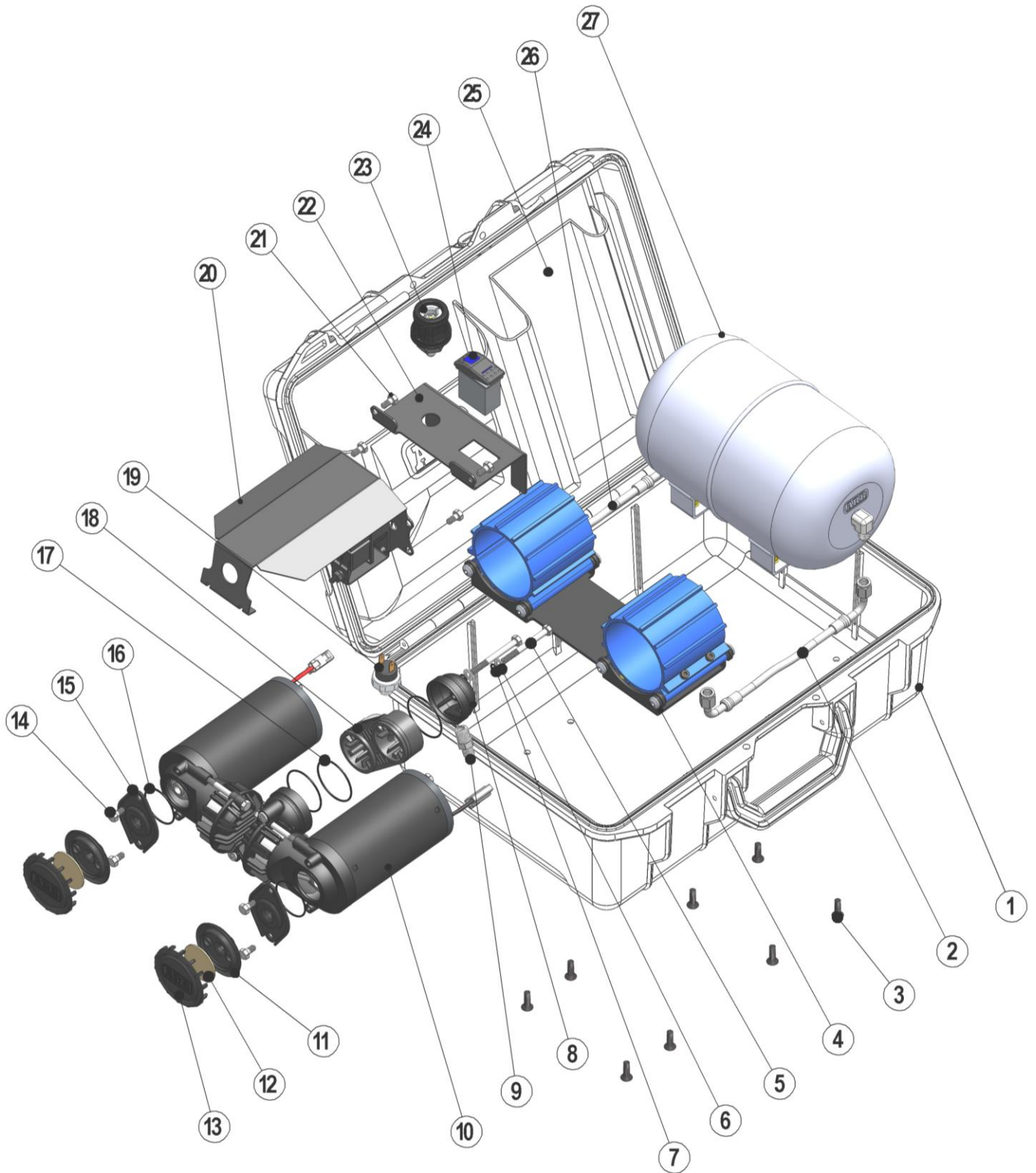

4 Parts List

CKMTP12

Portable Compressor Kit

| ITEM # | QTY | DESCRIPTION | PART # | NOTES |
|--------|-----|----------------------------------|-----------|-------|
| 01 | 1 | CARRY CASE | 270104 | |
| 02 | 1 | HOSE ASSEMBLY, TANK INPUT | 170305 | |
| 03 | 8 | SCREW (COUNTERSUNK M6 x 16) | 200715 | |
| 04 | 1 | TWIN COMPRESSOR MOUNT ASSEMBLY | 320108 | |
| 05 | 2 | MANIFOLD BOLT (M6 x 60mm) | 200716 | |
| 06 | 2 | FLAT WASHER | 6151046 | |
| 07 | 2 | O-RING (METRIC 6 x 2 N70) | 160242 | |
| 08 | 1 | MANIFOLD CAP (1/4" NPT) | 320214 | |
| 09 | 1 | ADAPTER (1/4" NPT TO JIC-4) | 170631 | |
| 10 | 2 | COMPRESSOR ASSEMBLY | CKM01 | |
| 11 | 2 | AIR FILTER BASE | 320501B | 1 |
| 12 | 2 | AIR FILTER ELEMENT (DISK TYPE) | 290503 | 1 |
| 13 | 2 | AIR FILTER COVER | 320501A | 1 |
| 14 | 6 | BOLT (M6 x 10mm) | 6151496 | |
| 15 | 2 | AIR FILTER FLANGE (1/4" NPT) | 320212 | |
| 16 | 2 | O-RING (BS029N70) | 160250 | 2 |
| 17 | 3 | O-RING (BS031N70) | 160241 | |
| 18 | 1 | COUPLER MANIFOLD | 320227 | |
| 19 | 1 | PRESSURE SWITCH (1/4" NPT) | 180901 | |
| 20 | 1 | COVER ASSEMBLY, CKMTP12 | 320109 | 3 |
| 21 | 2 | BOLT (M6 x 12mm), SWITCH BRACKET | 200702 | |
| 22 | 1 | SWITCH BRACKET, CKMTP | 320230 | |
| 23 | 1 | HOSE COUPLING (US STD FEMALE) | 171403 | |
| 24 | 1 | SWITCH w/ COVER (12V LED) | 180222 | |
| 25 | 1 | CARRY CASE POCKET | 270105 | |
| 26 | 1 | HOSE ASSEMBLY, TANK OUTPUT | 170306 | |
| 27 | 1 | AIR TANK | 171501 | |
| * | 1 | INFLATION ACCESSORY KIT (US STD) | 171303 | |
| * | 1 | HOSE ASSEMBLY (US STD) | 171310 | |
| * | 1 | AIR BLOW GUN | 171309 | |
| * | 1 | WIRING LOOM (CKMTP SUPPLY) | 180412 | |
| * | 1 | WIRING LOOM (CKMTP SWITCH) | 180413 | |
| * | 2 | RELAY (12V 40A SEALED) | 180905 | |
| * | 1 | OPERATION GUIDE | 2102MTP12 | |

* Not illustrated in exploded view.

Specs:

| | |
|-----------------|---|
| Voltage | 12 V DC |
| Current Draw | No-Load 28.4A Load 50.4A |
| Air Flow | 174.4L/min @ 0kPa [6.16CFM @ 0psi] 131.8L/min @ 200kPa [4.68CFM @ 29psi] |
| Total Weight | 15kg [33lbs] |
| Size | 186mm x 478mm x 355mm (H,L,W) [7.3" x 18.8" x 14"] |
| Outlet | Hose coupling, US std female |
| Pressure Switch | Open 1030kPa [150psi] Closed 930kPa [135psi] |
| Safety Valve | Open @ > ~1240kPa [180 PSI] |

Notes:

- 1 AIR FILTER BASE (11) & COVER (13) available only in AIR FILTER ASSY #320501 which also includes the element.
- 2 Complete set of CKM series O-ring seals is available as O-ring Service Kit #320301. (Order two for CKMTP12)
- 3 Cover assembly is preassembled with the relays, fan and wiring loom.