

Clutch Pressure Plate Bolt Pattern Tech Tip

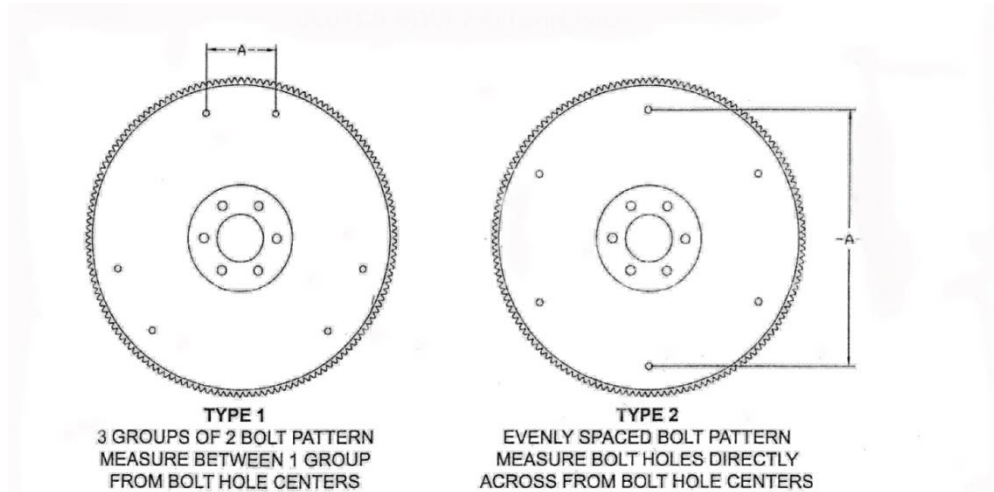

Clutch Pattern	Type	Dimension	Bolt Size	Dowel Pins
<u>FORD</u>				
8-1/2"	2	9-11/16"	5/16-18	
10"	1	3-1/8"	5/16-18	
10.4" Mustang '86+	2	11-3/8"	8mm x 1.25	YES
11"	1	3-3/8"	5/16-18	
11" Diaphragm	2	12-3/8"	3/8-16	
11" OHC Mustang 4.6L	2	12-3/8"	10mm x 1.50	YES
11-1/2"	1	3-9/16"	5/16-18	
<u>GM</u>				
9-1/8" V8 Fiero	2	10-9/16"	5/16-18	
10" - 10.4"	2	11-5/8"	3/8-16	
11" - 12"	2	12-5/8"	3/8-16	
11" - 11-1/2" GM LS1	2	12-5/8"	10mm x 1.50	YES
11" GM Pull Style	2	11-5/8"	3/8-16	
<u>CHRYSLER</u>				
10" - 10.4"	2	11-5/8"	3/8-16	
11" - 12"	2	12-5/8"	3/8-16	
12-1/4" Dodge Cummins	1	3-33/64"	5/16-18	Groups of 2
13" Dodge Cummins	1	3-21/32"	5/16-18	Groups of 2