

# INSTALLATION INSTRUCTIONS

## SG6 LED RUNNING BOARDS / SG6 RUNNING BOARDS



### PART NUMBER:

27-64710, 27-64715, 27-65710, 27-65715, 27-64720, 27-64725, 27-65720,  
27-65725, 27-64730, 27-64735, 27-65730, 27-65735, 27-64740, 27-64745,  
27-65740, 27-65745, 27-64750, 27-64755, 27-65750, 27-65755, 27-64760,  
27-64765, 27-65760, 27-65765

CONTENT			
ITEM	QUANTITY	DESCRIPTION	TOOLS NEEDED
1	2	END CAP "A"	PHILIPS-HEAD SCREWDRIVER
2	2	END CAP "B"	WIRE CUTTER
3	2	ALUMINUM EXTRUSION	
4	2	CLOSE OUT PANEL	
5	2	RUBBER PAD	
6*	1	WIRING HARNESS	
7	12	M4 PAN HEAD SCREW	
8*	8	DOUBLE SIDED TAPE	
9*	4	MAGNETIC SWITCH	
10*	4	LED LIGHT	
11*	12	ZIP TIES	

\* SG6 LED RUNNING BOARDS ONLY

**ANTI-SEIZE LUBRICANT MUST BE USED ON ALL STAINLESS STEEL FASTENERS TO PREVENT THREAD DAMAGE AND GALLING**

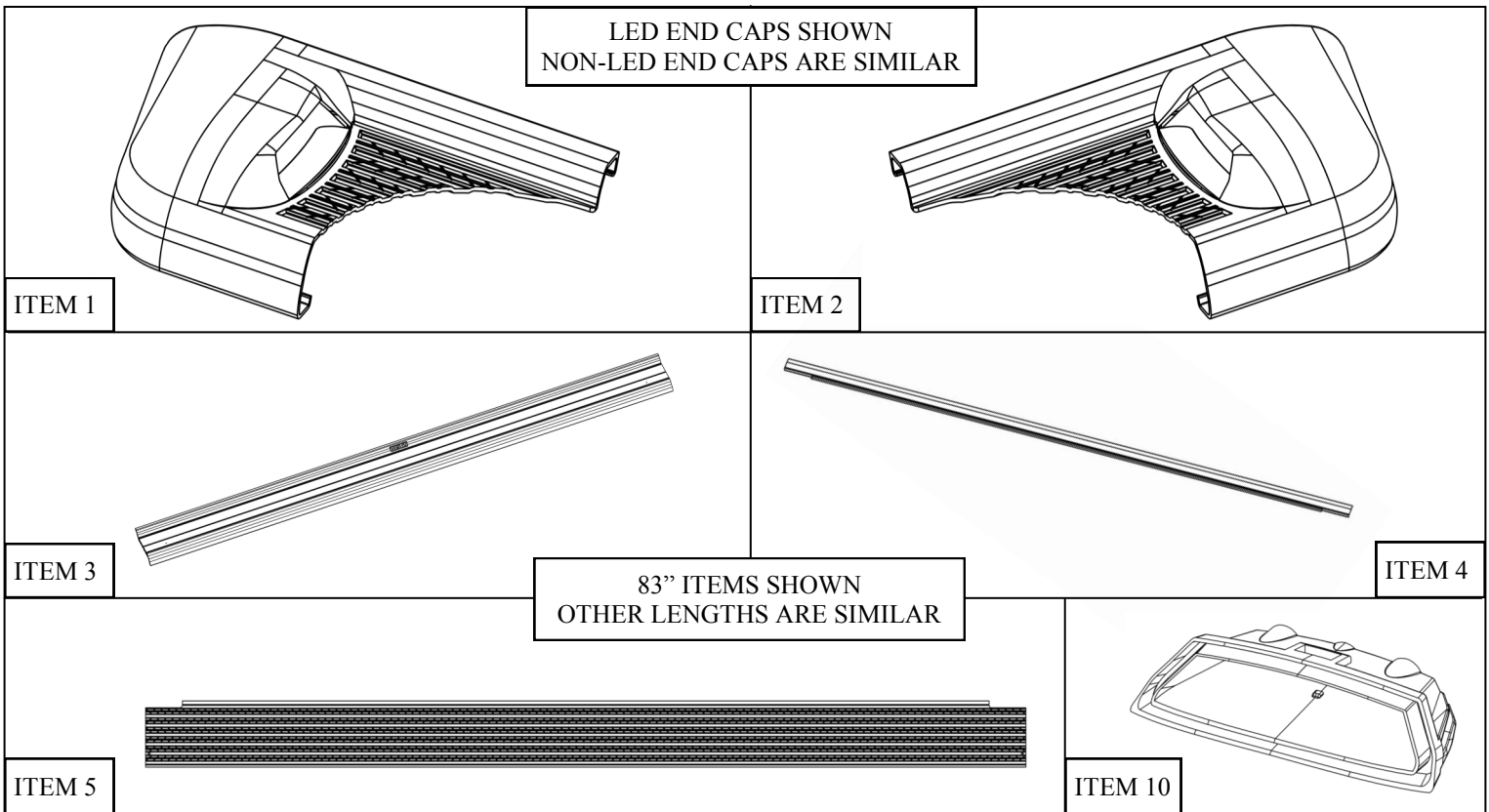

## PROCEDURE

1. Remove contents from box, verify if all parts listed are present and free from damage.  
Carefully read and understand all instructions before attempting installation.  
**Failure to identify damage before installation could lead to a rejection of any claim.**

### Close Out Panel Installation (Optional)

For vehicles with the required space, the close out panel can be installed to fill the area above the running board.

Remove Three Pan Head Screws and Slide End Cap Off of Aluminum Extrusion

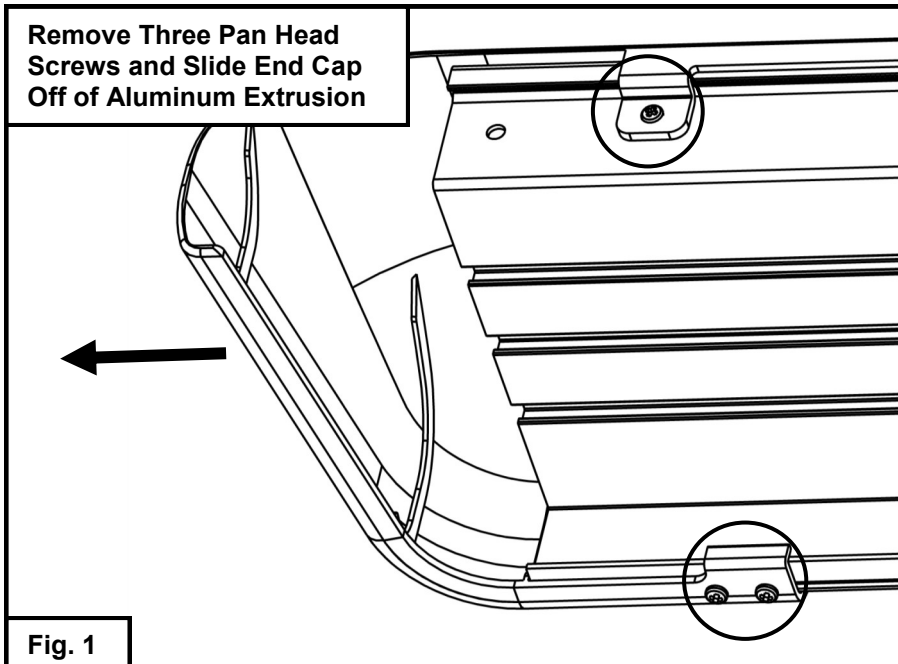

1. Remove one of the End Caps (1 or 2) by removing the three M4 pan head screws (7) from the back and bottom of the End Cap and sliding the End Cap off of the Aluminum Extrusion (3). See **Figure 1**.

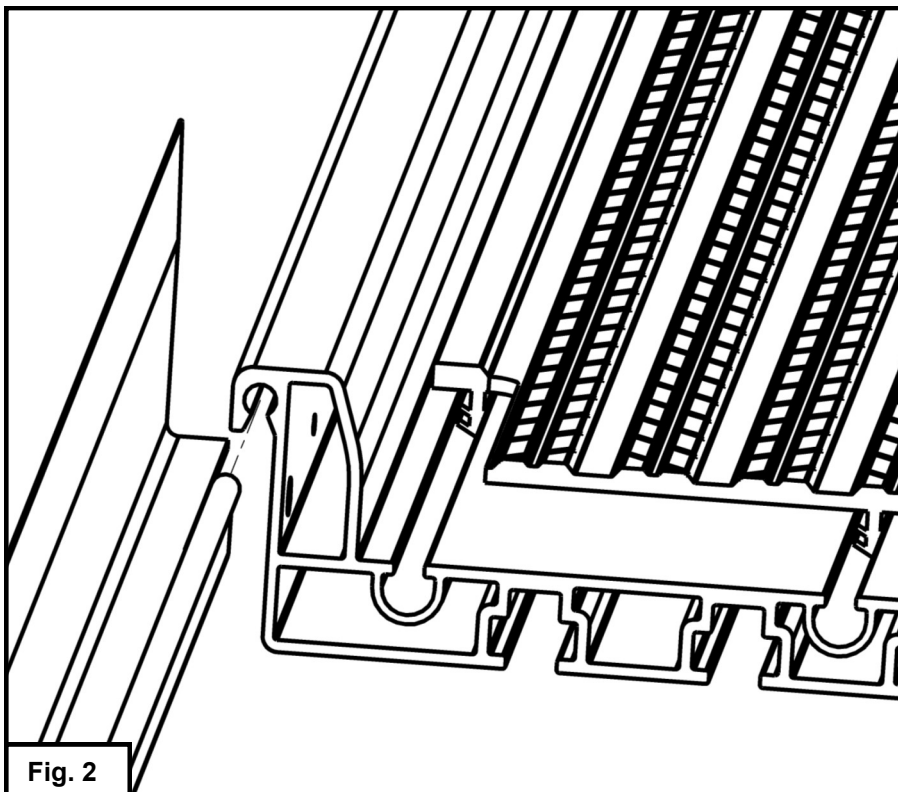

2. Slide a Close Out Panel (4) into the groove in the back of the Aluminum Extrusion (3). See **Figure 2**.

**WESTIN**

Westin Automotive Products, Inc.  
320 W. Covina Blvd  
San Dimas, Ca. 91773

3. Replace the End Cap (1 or 2) that was removed in **Step 1** and reinstall the M4 pan head screws (7). See **Figure 3**.

**Fig. 3**

**SG6 LED Running Board Assembly**

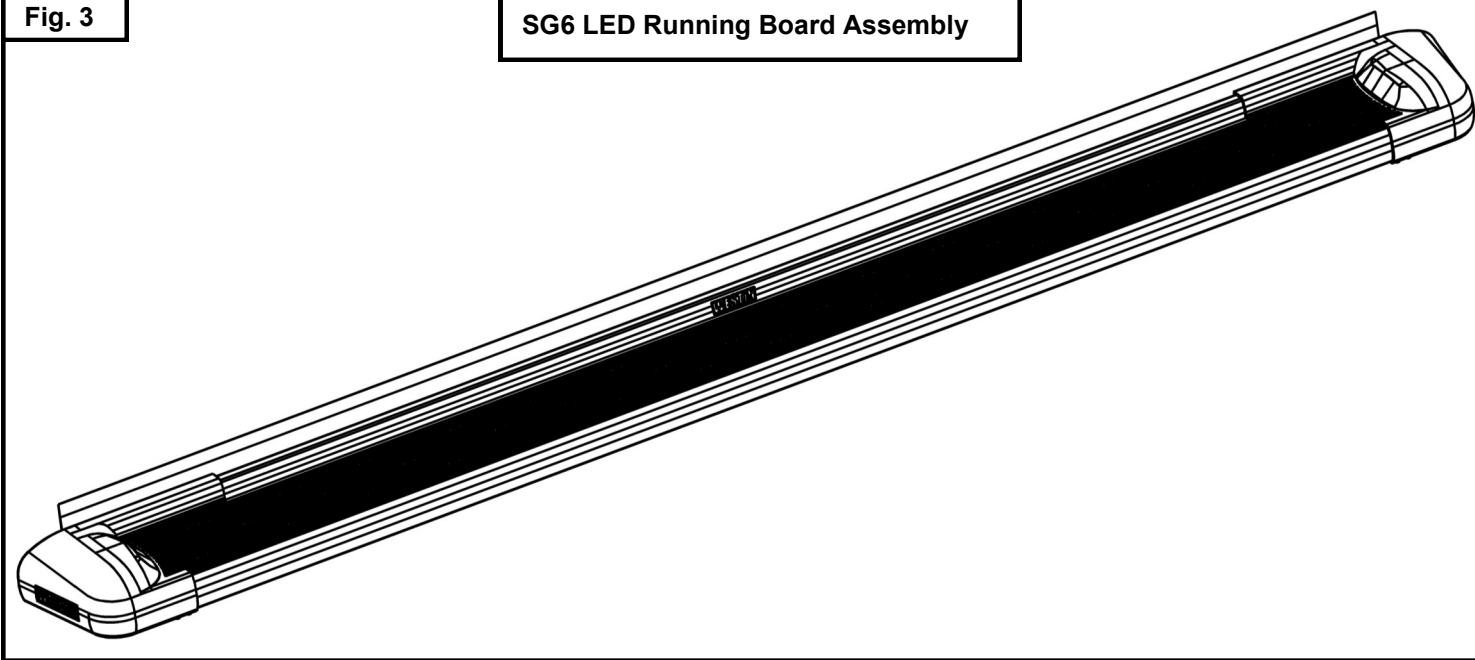

For SG6 LED Running Boards:

### Wiring Harness and Magnetic Switch Installation (Varies with Vehicle)

**Note:** Install wiring harness and magnetic switches after mounting the running boards onto the vehicle. Refer to mount kit installation sheet for mounting instructions.

**Fig. 4**

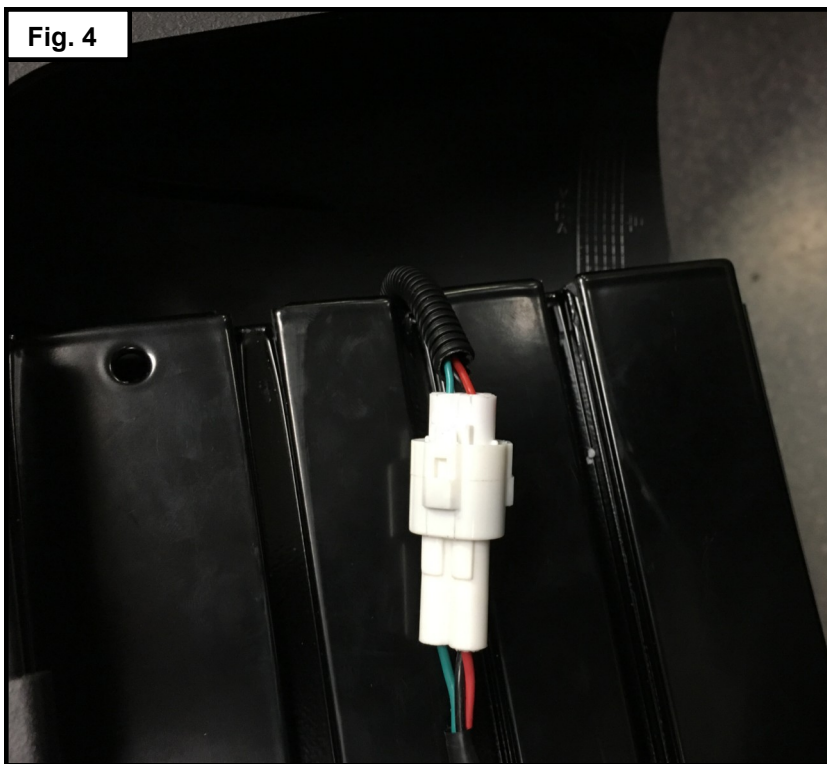

1. Connect the Wiring Harness (6) to each LED Light (10). See **Figure 4**.
2. Install the magnetic switches. Refer to **Pages 4 & 5** for examples.



**ALL VEHICLES WILL HAVE DIFFERENT WAYS TO MOUNT THE MAGNETIC SWITCHES PROPERLY.  
MOUNT IN THE BEST APPLICATION FOR YOUR VEHICLE**

**SEE BELOW FOR DIFFERENT EXAMPLES**

1. For each door, find a suitable location on the door and the cab of the truck to mount the Magnetic Switches (9).  
**The switches must line up and cannot be more than 2 cm apart.**
2. Once a location is found, place the Double Sided Tape (8) as shown in **Figure 5**.



3. Place the Magnetic Switches (9) on the Double Sided Tape (8). **Note:** It is extremely important that the switches face each other. They will not work if positioned incorrectly. **See Figure 6.**



SEE BELOW FOR DIFFERENT EXAMPLES

1. For each door, find a suitable location on the door and the cab of the truck to mount the Magnetic Switches (9).  
**The switches must line up and cannot be more than 2 cm apart.**
2. Once a location is found, place the Double Sided Tape (8) and Magnetic Switch (9) as shown in **Figures 7, 8 & 9.**  
**Note:** Suggested location shown.

Place Switch on Bottom Edge of Door Towards the Rear



Place the Other Switch on the Edge of Rocker Panel Just Below the Door

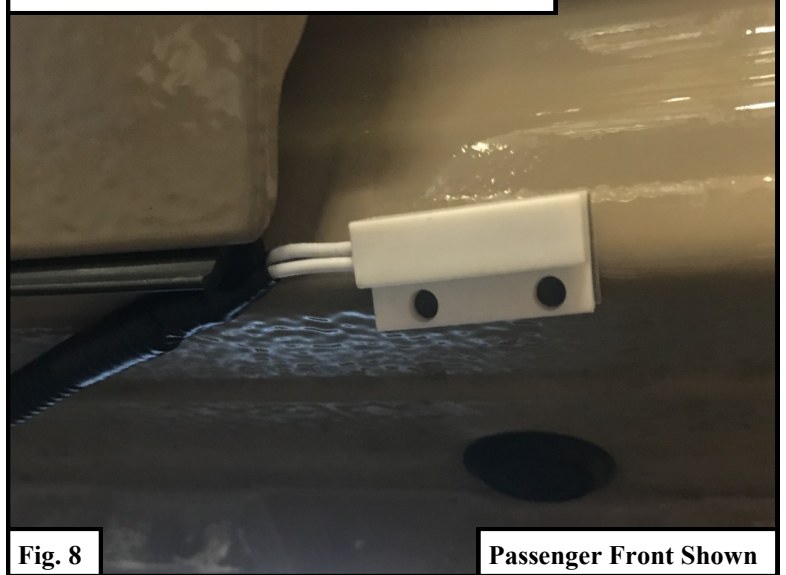

3. Repeat the process for the rear door locations.

SEE BELOW FOR DIFFERENT EXAMPLES

1. For each door, find a suitable location on the door and the cab of the truck to mount the Magnetic Switches (9).  
**The switches must line up and cannot be more than 2 cm apart.**
2. Once a location is found, place the Double Sided Tape (8) and Magnetic Switch (9) as shown in **Figure 10** . *Note:* Suggested location shown. *Note:* It is extremely important that the switches face each other. They will not work if positioned incorrectly.

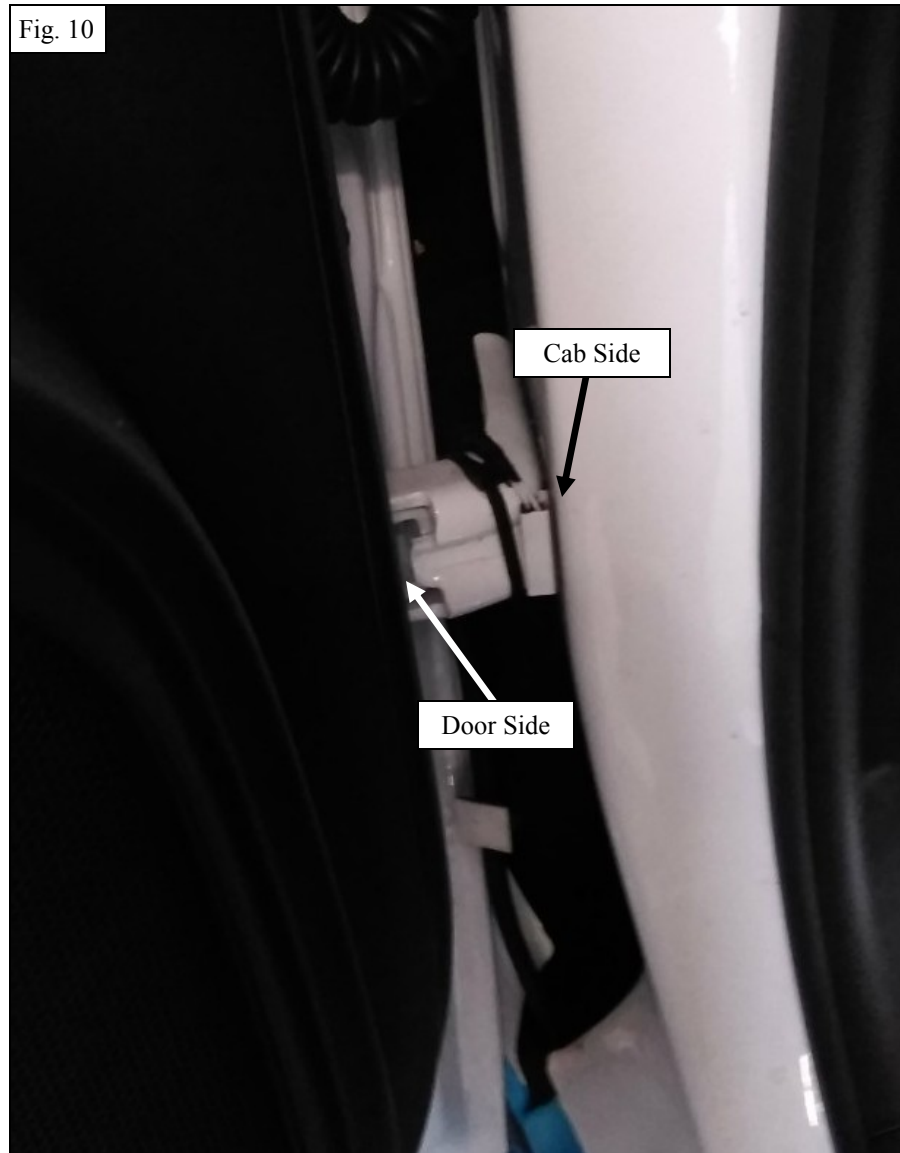



3. Run the Wiring Harness (6) to the engine compartment. Use Zip Ties (11) as needed to secure slack wiring. See Figure 10.

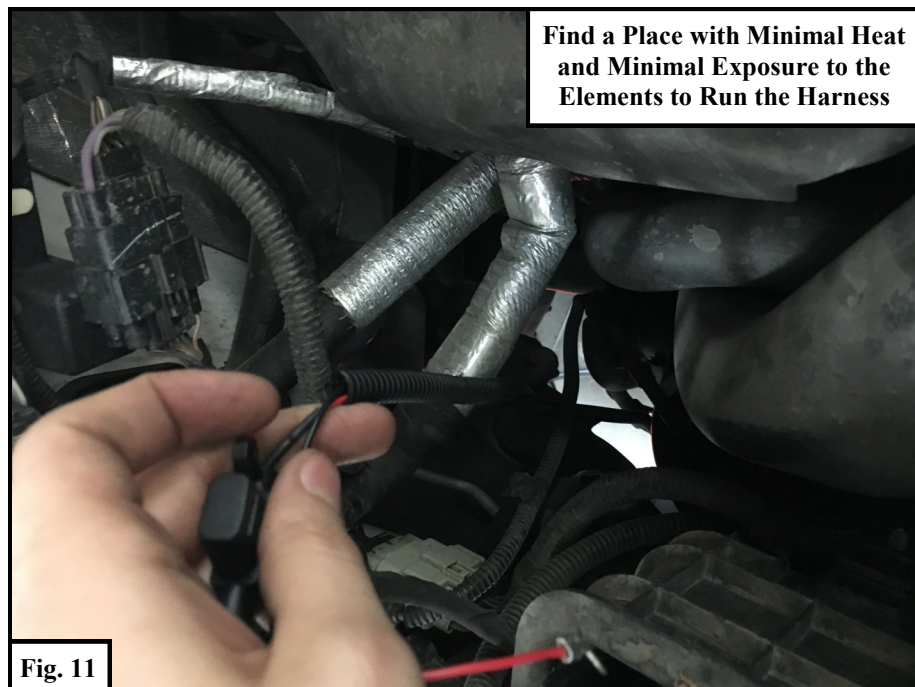

4. Be sure to disconnect the battery prior to connecting the wiring harness.
5. Connect the red ring connector to the positive terminal on the battery and the black ring connector to the negative terminal. See Figures 11 and 12.
6. Reconnect the battery.

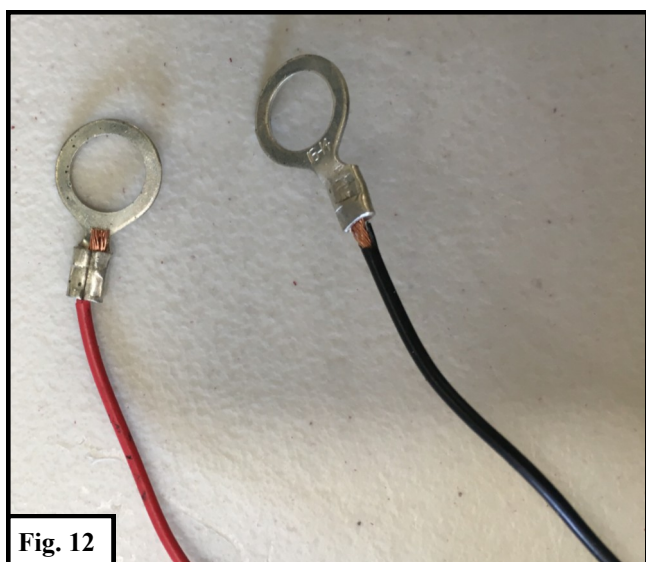





INSTALLATION COMPLETE

#### CARE INSTRUCTIONS

- REGULAR WAXING IS RECOMMENDED. DO NOT USE ANY TYPE OF POLISH OR WAX THAT MAY CONTAIN ABRASIVES.
- STAINLESS STEEL PRODUCTS CAN BE CLEANED WITH MILD SOAP AND WATER. STAINLESS STEEL POLISH SHOULD BE USED TO POLISH SMALL SCRATCHES.
- GLOSS BLACK FINISHES SHOULD BE CLEANED WITH MILD SOAP AND WATER.

**WESTIN**

Westin Automotive Products, Inc.  
320 W. Covina Blvd  
San Dimas, Ca. 91773

Thank you for choosing Westin products  
for additional installation assistance please call  
Customer Service (800) 793-7846

[www.westinautomotive.com](http://www.westinautomotive.com)





## WARNING



Failure to follow these instructions could lead to death, personal injury, and / or property damage.

Failure to follow these instructions could lead to death, personal injury, and / or property damage.

### FASTENERS:

All Westin supplied fasteners must be utilized and installed in accordance with the installation instructions and apply torque to the specifications as defined. **DOUBLE CHECK ALL FASTENERS BEFORE INITIAL USE, AND PERIODICALLY IN THE FUTURE TO ENSURE PROPER FUNCTION AND SAFETY.**

### DRILLING:

Most Westin products do not require drilling for installation. If drilling is defined as required, use caution when drilling a vehicle. **FAILURE TO REVIEW AN AREA TO BE DRILLED MAY RESULT IN PERSONAL INJURY AND/OR INJURY TO OTHERS AS WELL AS VEHICLE DAMAGE.**

### EYE PROTECTION:

**ALWAYS WEAR SAFETY GLASSES OR GOGGLES DURING THE INSTALLATION PROCESS TO AVOID PERSONAL INJURY.**

### MAXIMUM TOWING/CARRYING CAPACITY:

The Westin Receiver Hitches will have a visible tow rating label affixed directly on the product. User should never exceed the vehicle manufacturers maximum tow and weight rating regardless of the capacity of the hitch. **FAILURE TO FOLLOW THESE GUIDELINES WILL VOID THE WESTIN WARRANTY AND MAY RESULT IN PERSONAL INJURY AND/OR INJURY TO OTHERS AS WELL AS VEHICLE DAMAGE.**



Westin Automotive Products, Inc.  
320 W. Covina Blvd  
San Dimas, Ca. 91773

Thank you for choosing Westin products  
for additional installation assistance please call  
Customer Service (800) 793-7846  
[www.westinautomotive.com](http://www.westinautomotive.com)