

Xtra Air Command™

INSTALLATION INSTRUCTIONS

Congratulations on your purchase of a new Air Command kit. This kit was designed to provide inflation control of your air helper springs. This kit will be an asset to your vehicle, meeting your air supply needs.

Please take a few minutes to read through the instructions, identify the components, and learn how to properly install your Air Command kit.

NOTE:

The Air Command kit can be used with most air helper spring products. If you are installing an air helper spring kit, do not install the air line tubing into the air springs as stated in the air helper spring manual. If you are adding the Air Command kit to an existing air helper spring system, you will need to deflate the air springs and remove the air line tubing.

NOTE ON CONNECTING THE AIR LINE TUBING

Cut the air line tubing as square as possible. To connect the air line tubing to the fittings, push the tubing into the fitting as far as possible. If for any reason the tubing must be removed, make sure the air helper springs are deflated, then push the collar of the fitting toward the body of the fitting and the tubing can be removed. To reassemble, make sure the tubing is cut square and push back into the fitting.

STEP 1—PREPARE THE COMPONENTS

A) COMPRESSOR

Install the push-to-connect T-fitting into the threaded exhaust port on the compressor head *see Figure "A"*. Tighten the fitting sufficiently to engage at least two threads with pre-applied orange thread sealant. Do not overtighten the fitting. Install the pressure switch into the female end of the T-fitting. Crimp a blue female spade connector onto the positive (red) compressor wire. Install the female spade connector on either spade on the pressure switch *see Figure "A"*. Install the air filter into the threaded inlet port on the compressor head in the same manner as the T-fitting was installed. Crimp a ring connector onto the negative wire (black) from the compressor.

B) AIR TANK

Thread two 1/4" NPT male push-to-connect fittings into the air ports on the air tank *see Figure "A"*. Tighten the fittings securely to engage at least two threads with the pre-applied orange thread sealant.

STEP 2—SELECT A MOUNTING LOCATION

A) COMPRESSOR ATTACHMENT

Begin by removing the negative battery cable. Select a convenient location to mount the compressor. This location should provide ample air flow and be protected from airborne debris and moisture. The mounting surface should be rigid to support the compressor, such as under the hood on a fender well or in a vented storage compartment. The compressor is oil-less and can be mounted in any orientation necessary for installation.

PARTS LIST

COMPRESSOR	9499	1	COMPRESSOR T-FITTING	1
AIR TANK	9124	1	PUSH-TO-CONNECT T-FITTING	2
PRESSURE SWITCH	9016	1	PUSH-TO-CONNECT MALE FITTING	2
SINGLE AIR CONTROL PANEL	2570	1	NYLON TIE	15
30 FT. AIR LINE TUBING	9416	2	15 FT. 18 GAGE WIRE	1
#10-32 X 1" MACHINE SCREW		6	FEMALE TERMINAL	1
#10-32 LOCK NUT		6	RING TERMINAL	1
#10 FLAT WASHER		10	WIRE CONNECTOR	2
3/8" -16 1" HEX BOLT		2	IN-LINE FUSE HOLDER	1
3/8" -16 FLANGED HEX NUT		2	20 AMP BLADE FUSE	1
3/8" FLAT WASHER		2		

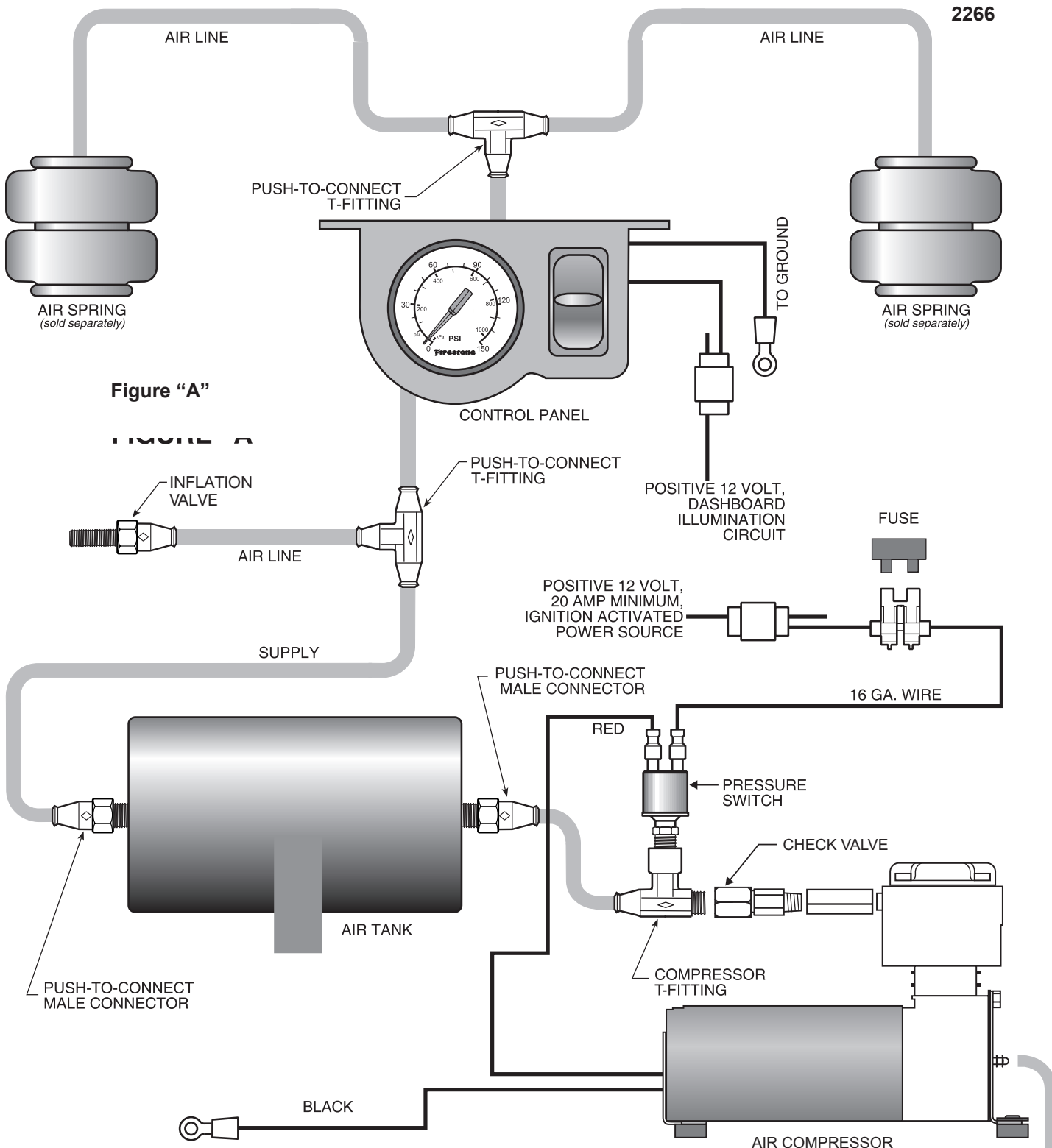
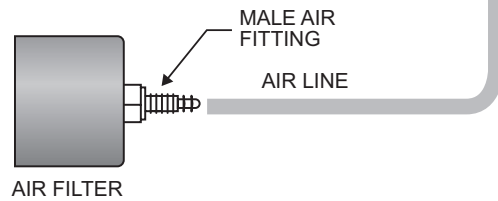

Figure "A"

FIGURE A

Connectors:

- Female Terminal Connector
- Ring Terminal
- Wire Connector
- Inline Fuse Holder



Using the compressor as a template and a center punch, mark and drill four 3/16" holes in the mounting surface. Any burrs in the holes should be removed to prevent damage to the rubber isolators. Mount the compressor using the supplied 10 -32 x 1" machine screws, 10 -32 lock nuts, and 3/16" washers *see Figure "B"*. Maximum vibration isolation can be achieved by properly mounting the compressor. The machine screw and nut should be tightened only enough to bottom-out the brass insert *see Figure "B"*. **DO NOT OVERTIGHTEN.** Overtightening will crush the brass insert and the rubber isolator, thereby reducing vibration isolation. Attach the ring terminal on the negative wire to a suitable ground source on the vehicle.

B) AIR TANK ATTACHMENT

Select a location to mount the air tank. This should be in a protected location to prevent damage from rocks or airborne debris. Mark and drill two 7/16" holes 2-1/2" apart to match the holes on the air tank brackets. Bolt the air tank in place using the 3/8" -16 x 1-1/2" hex bolts with the 3/8" -16 flanged hex nuts and 3/8" washers provided. Ensure that the installation allows unrestricted access to the air ports on the tank.

C) CONTROL PANEL ATTACHMENT

Select a mounting surface for the control panel under the dashboard of your vehicle or other protected location. Using the control panel as a template, center mark the mounting holes on the dashboard. Drill a 3/16" hole on each center mark *see Figure "D"*. Do not attach the control panel to the dashboard at this time.

STEP 3—ROUTE THE AIR LINE

A) AIR TANK AND COMPRESSOR TO CONTROL PANEL

Cut a piece of air line tubing that will reach from the control panel to the air tank. Insert the end of the air line tubing into the port marked "IN" on the back of the control panel. Route the air line to the air tank *see Figures "A" & "C"*. It may be necessary to drill a hole in the firewall to route the air line. Make sure that the air line tubing is protected from sharp edges. A rubber grommet may be installed in the hole in the firewall to protect the tubing from chafing. Insert the other end of the tub-connect fitting on the air tank *see Figure "A"*. Secure the tubing to the vehicle with the provided nylon ties.

B) CONTROL PANEL TO AIR SPRINGS

Cut two lengths of air line tubing that will reach from the gauge panel to each of the air helper springs. Route the air line so that the left paddle switch controls the left air spring and the right paddle switch controls the right air spring. It may be necessary to drill a hole in the firewall to allow the air line tubing to reach the rear of the vehicle. Ensure that the air line tubing is protected from sharp edges. Before installing the tubing to the gauge panel, soak one end of the tubing (1") in hot water for a few minutes to soften the tubing. Slide the tubing onto the barbed fitting on the back of the gauge panel as far as possible. Do not use pliers to work the air line onto the barbed fitting, as the tubing may be damaged.

Install the other end of the air line tubing into the push-to-connect fitting on the air spring *see Figure "A"*. Insert the tubing as far as possible into the fitting. Route the tubing to avoid sharp edges and direct heat from the exhaust system. Secure the tubing to the vehicle with the nylon ties provided.

STEP 4—ROUTE THE ELECTRICAL WIRE

All necessary electrical wire and connectors have been included with this kit. Review the electrical schematic before beginning installation *see Figure "A"*.

Secure the ring terminal to a grounded component of the chassis. Route a length of wire from the pressure switch to a positive 12 Volt, 20 Amp minimum, ignition activated power source on the vehicle. Cut a length of 16 gage wire from the 15' length included with this kit. Crimp a blue female spade connector on to one end of the 16 gage length of wire. Install the female spade connector over the remaining spade on the pressure switch. Connect the opposite end of the pressure switch wire to the 12 Volt power wire using a wire connector. Slide the wire

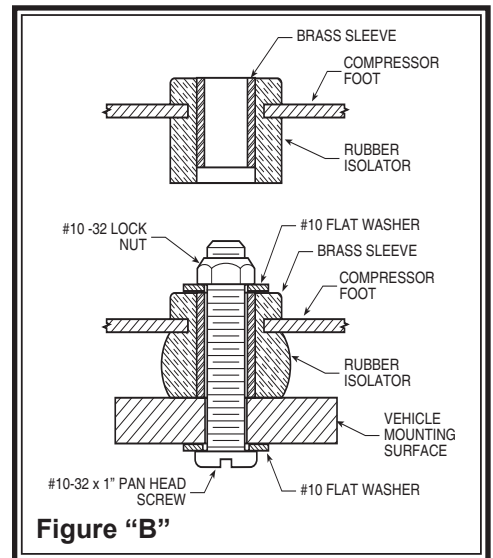

Figure "B"

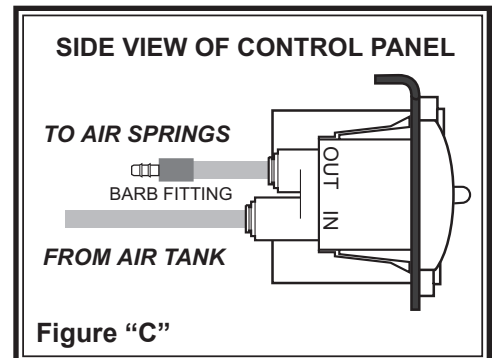

Figure "C"

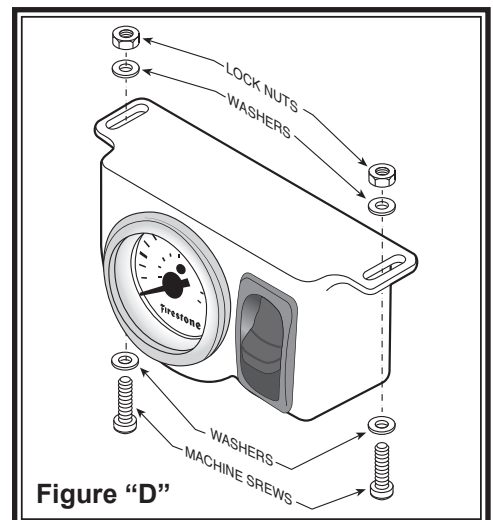

Figure "D"

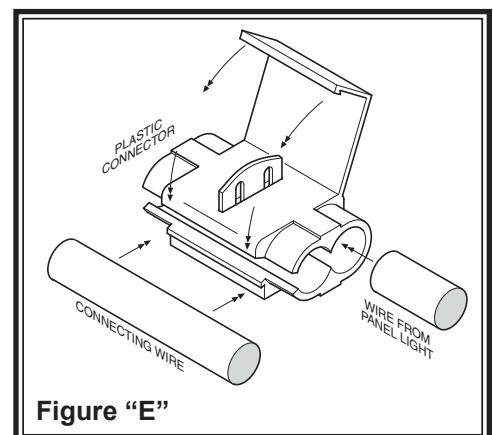

Figure "E"

connector over the existing wire and insert the un-stripped wire from the pressure switch into the wire connector. Close the wire connector over both wires with pliers **see Figure "E"**.

Install the in-line fuse holder in the positive pressure switch wire. Cut the pressure switch wire near the wire connector and insert the un-stripped ends of the wire into the fuse holder. Close the fuse holder over the wires with pliers and install the 20 Amp blade fuse **see Figure "F"**.

STEP 5—WIRE THE CONTROL PANEL FOR ILLUMINATION

There are two wires (one red and one black) attached to the gauge on the back of the control panel. Connect the red wire to a fused dashboard illumination wire. Connect the black wire to a suitable ground source **see Figure "G"**.

Attach the end of the positive wire to a dashboard illumination wire using a wire connector. Slip the wire connector over the existing dashboard illumination wire and insert the un-stripped gauge panel wire into the wire connector. Close the wire connector on to the wires with pliers **see Figure "E"**. Attach the black wire to a ground source by crimping a red ring connector on to the wire and securing it to a suitable ground source on the vehicle. **Note:** Use the supplied 18 gage multi-strand wire to reach a dashboard illumination wire and ground source.

STEP 6—ATTACH THE CONTROL PANEL TO THE DASHBOARD

Install the control panel on the dashboard where the holes were drilled in **Step 2C**. Attach the panel to the dashboard or other mounting surface using the enclosed 10 -32 x 1" machine screws, 10 -32 lock nuts, and #10 washers **see Figure "D"**.

STEP 7—TEST THE SYSTEM

With the Air Command kit and air helper springs installed, you are ready to test the system. Reattach the negative battery cable. Turn on the ignition. The compressor will start and build pressure in the system. Push the paddle switches upward to inflate the air springs. The gauge will display how much air pressure is in each air spring. Inflate the air helper springs to 70 P.S.I. and check the fittings for air leaks with an applied solution of soap and water. If a leak is detected at a tubing connection, check to make sure that the tube is cut as square as possible and that it is pushed completely into the fitting. The tubing can easily be removed from the fitting by first releasing the pressure from the air spring, then by pushing the collar towards the body of the fitting and then pulling out the air line tubing.

SYSTEM OPERATION

The Air Command kit allows the air springs to be inflated from the inside of the vehicle. Push the paddle switches up to inflate the air springs and down to deflate the air springs. This air accessory kit provides front-to-rear and side-to-side leveling.

If the air compressor fails to operate for any reason, air can be introduced into the system by using the manual inflation valve installed with the Air Command kit. This can be accomplished by inflating the system through the manual inflation valve.

