

Read installation instructions completely before installing.

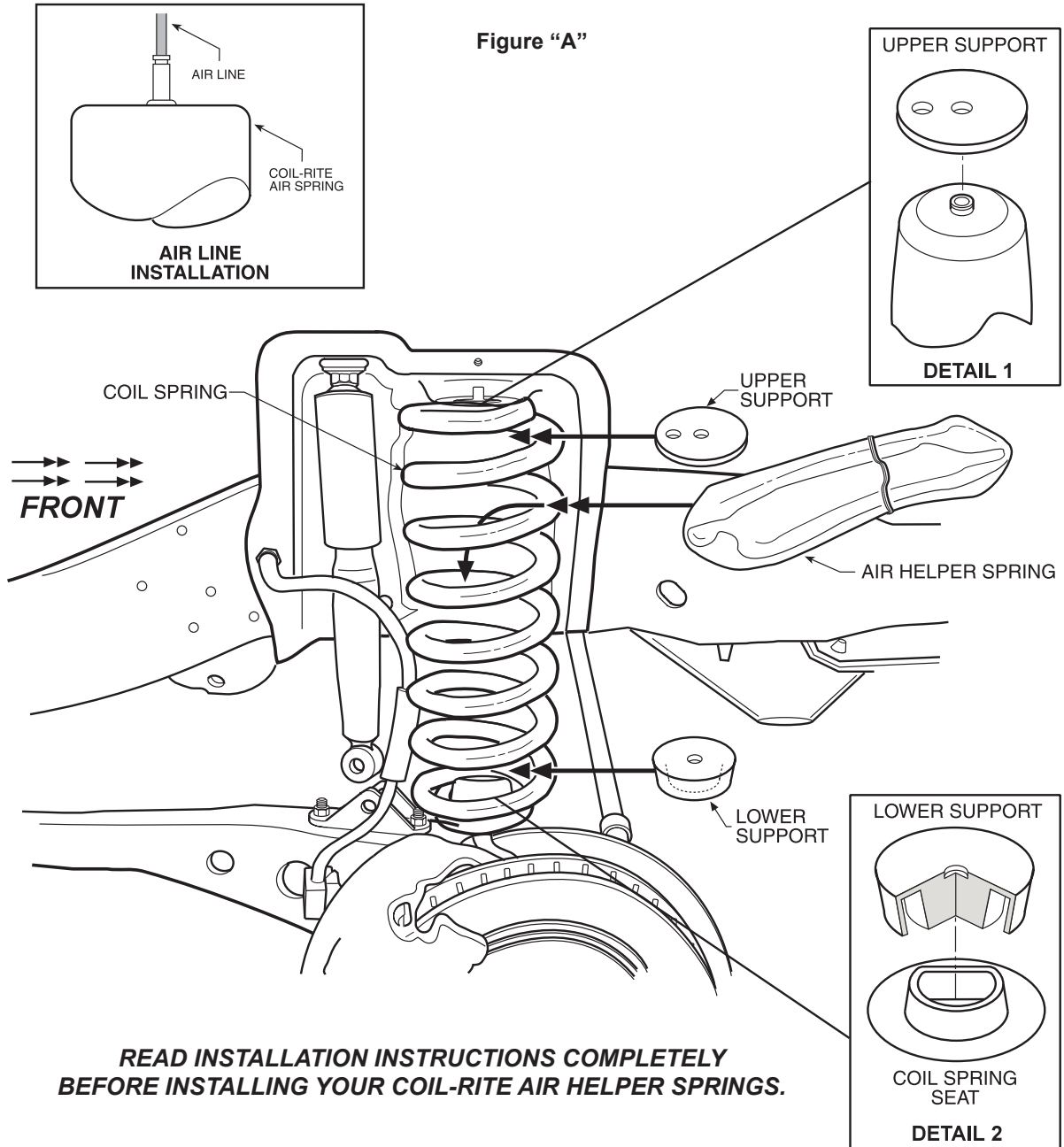

**READ INSTALLATION INSTRUCTIONS COMPLETELY
BEFORE INSTALLING YOUR COIL-RITE AIR HELPER SPRINGS.**

PARTS

QTY. OPERATING PRESSURES

AIR SPRINGS	6125	2	PICK-UP	5-60 PSI
UPPER SUPPORTS	0027	2		
LOWER SUPPORTS	0040	2		
18' AIR LINE		1		
NYLON TIE		6		
INFLATION VALVE		2		
5/16" FLAT WASHER		4		
STRAIGHT FITTING ASSEMBLY	0048	1		

STEP 1—VEHICLE PREPARATION

Remove the negative battery cable. With the vehicle on a solid level surface, chock the rear wheels. Using a jack rated for the weight of your vehicle, raise the wheels off the ground. Lower the vehicle frame onto jack stands rated for the vehicle weight, making sure the suspension is fully extended. (Do not use wood or concrete blocks to support the vehicle.)

STEP 2—REMOVE THE COIL SPRING

Put a jack under the axle on the left side of the vehicle. Remove the lower bolt from the shock absorber and from the sway bar end link. Lower the axle until the coil spring is fully extended. **Caution: DO NOT put tension or strain on any flexible brake lines.** Place the lower protector in the bottom of the coil spring.

STEP 3—INSTALL THE AIR SPRING

Deflate the air spring and place it inside the coil spring with the air fitting pointing up (**Figure "A"**). Next, place the upper protector on top of the air spring. Cut the air line into to equal lengths, making sure the ends are cut as squarely as possible (a "sawing" motion with a razor blade is preferred). Route the air line through the frame and out through the center of the coil spring. Once the air is completely inside the coil spring, remove the valve stem and allow the air spring to return to its normal position.

STEP 4—REINSTALL THE COIL SPRING

Reattach the bottom of the shock absorber and sway bar end link and tighten the bolt to manufacturers' specifications. For installation on the right side, repeat Steps 2 through 5.

STEP 5—INSTALL THE INFLATION VALVES

Choose a location to mount the inflation valves, this should be a protected location such as the rear bumper. Drill two 5/16" holes and pass the valves through and tighten the nuts. **See Figure "F"**.

STEP 6—ROUTE THE AIR LINE

Route the air line from the air springs to the inflation valves (**Figure "E"**). Avoid any sharp edges or hot surfaces as well as sharp angles. The air line can be secured with the nylon ties provided. Cut off any excess air line using the method mentioned above and push the end as far as possible into the inflation valve.

STEP 7—INFLATE AND TEST

Inflate the air springs to recommended maximum operating pressure (see page 1 for operating pressures). With a soap and water solution, check for air leaks around the fittings and valve core. Inflate and deflate in small increments to find the ideal riding conditions for your vehicle.

STEP 8—COMPLETION

Raise the vehicle, remove the jack stands, and lower the vehicle to the ground. Reattach the battery cable.

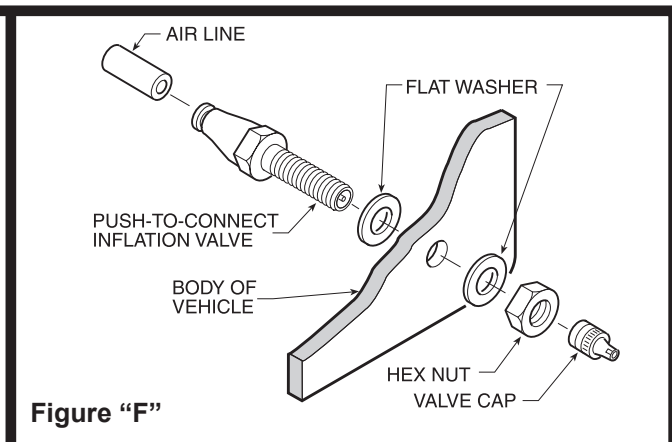
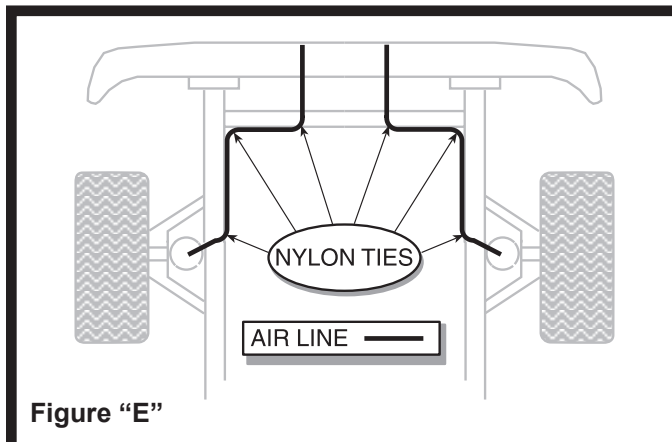



Do Not Return This Product to the Dealer or Distributor

If you are

- missing parts,
- experiencing installation problems, or
- have technical concerns regarding this product,

you may contact a Firestone Technical Service Representative at rrtech@fsip.com or at 800-888-0650 (option 1, and then option 2). Representatives are available from 7:30 a.m. – 4:30 p.m. Eastern on Monday – Friday, excluding holidays. If you are located outside of the United States, you should first contact your distributor or dealer directly with any issues.

When contacting Technical Service, please have the kit or part # ready, along with the make, model, and year of the vehicle. You may also need to provide details, such as 2WD/4WD or if the vehicle has been lifted or lowered from stock height.

If you have a warranty concern, please include in your email a detailed description of the situation, a photo(s) of the issue, and your contact information, including ship-to address.

WARRANTY COVERAGE*— The Ride-Rite™ kits, components, and accessories are warranted against defects in workmanship and materials. This warranty does not cover service or labor charges, neglect...to the product.

PERIOD OF COVERAGE:

- | | |
|---|--|
| • Ride-Rite air springs – Lifetime Limited | • Work-Rite load assists – 2 Years Limited |
| • Sport-Rite air springs – Lifetime Limited | • Air-Rite accessories – 2 Years Limited |
| • Coil-Rite air springs – Lifetime Limited | • Brackets, hardware, fittings, air line, and other components – 2 Years Limited |
| • Level-Rite air springs – Lifetime Limited | |

HOW TO MAKE A WARRANTY CLAIM — If you purchased your air springs in the U.S. or Canada and believe you have a part with a warrantable defect, call Firestone directly at 1-800-888-0650.

International customers should contact their distributors or dealers directly with any problems.

(*) Please refer to the “Firestone Limited Lifetime Air Spring Warranty” for details, terms, and conditions.

WARRANTY QUESTIONS

Go to www.riderite.com/installation-support
Select “Warranty Info” tab