

**advanced FLOW engineering** Quantum Air Intake

**Instruction Manual** P/N: 53-10004D / 53-10004R

Make: **Ford** Model: **F-250/F-350/F-450/F-550** Year: **2017-2019** Engine: **V8-6.7L (td) Power Stroke**



- Please read the entire instruction manual before proceeding.
- Ensure all components listed are present.
- If you are missing any of the components, call customer support at 951-493-7100.
- Ensure you have all necessary tools before proceeding.
- Do not attempt to work on your vehicle when the engine is hot.
- Disconnect the negative battery terminal before proceeding.
- Retain factory parts for future use.

Label	Qty.	Description	Part Number
A1	1	Air Filter (Pro DRY S)	21-90103
A2	1	Air Filter (Pro 5R)	23-91132
B	1	Tube	05-53006B1
C	1	Housing	05-53006B2
D	1	Coupling, Silicone Bellow	05-01457
E	1	Coupling, Silicone Hump	05-01204
F	1	Washer: M6	03-50070
G	2	Screw, Torx: M4	03-50491
H	1	Screw, Hex Hd: M6	03-50057
I	1	Fixing Clamp, 3/4"	03-50234
J	3	Clamp, #072	03-50010
K	1	Clamp, #080	03-50011
L	1	Grommet	03-50033
M	1	Cap	03-50103

**Installation will require the following tools:**

7mm, 8mm, 10mm, nut driver or socket and extension, T-20 Torx, Phillips #3 screwdriver.

Note: Legal in California for use on race vehicles only. The use of this device on vehicles used on public streets or highways is strictly prohibited in California and others states that have adopted California emission regulations.

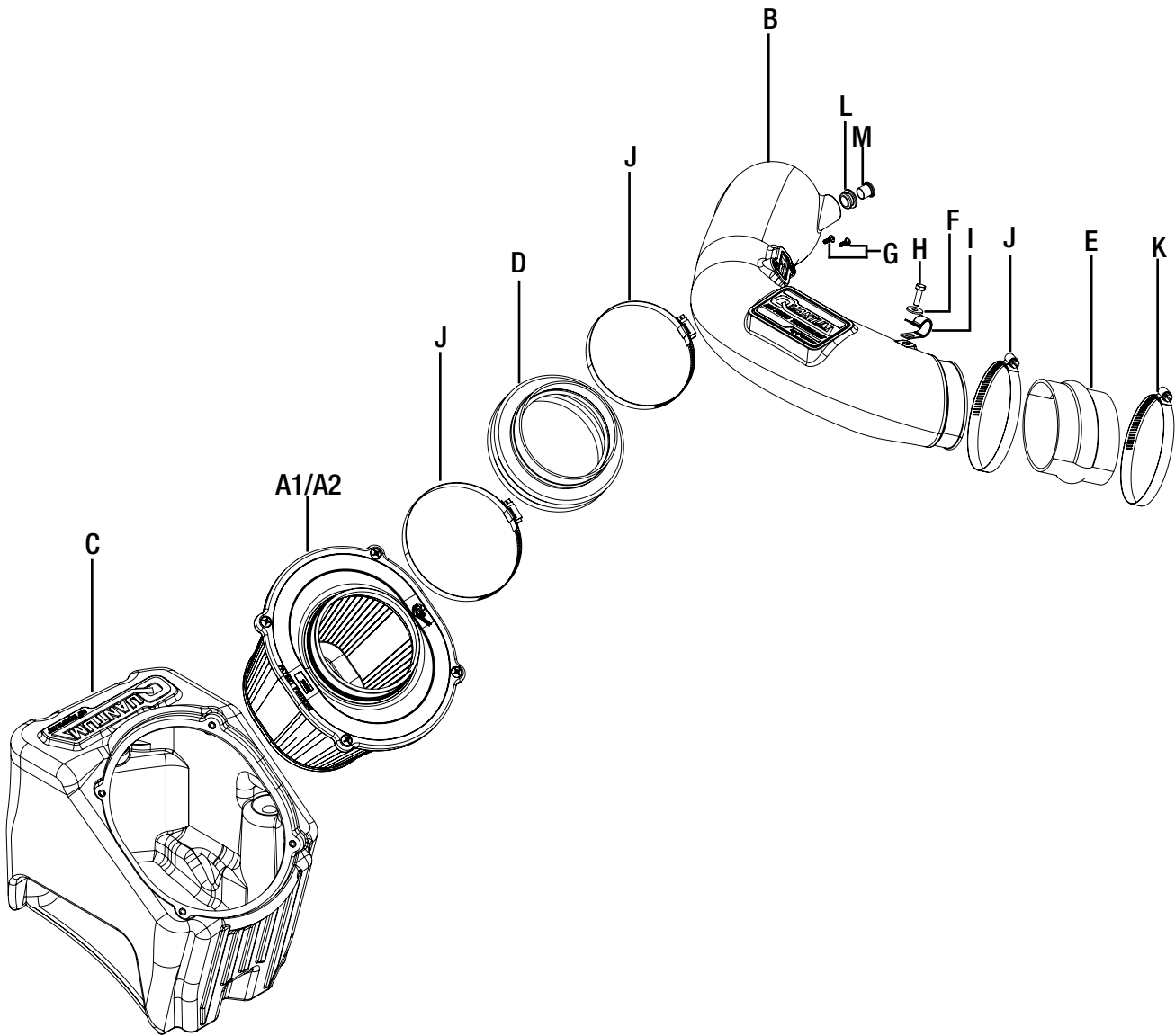

**Figure A****Refer to Figure A for Step 1**

Step 1: Using a 7mm nut driver, loosen the clamps ① at the turbo inlet and the airbox. Remove the hose ② from the intake tube clip and remove the intake tube ③.

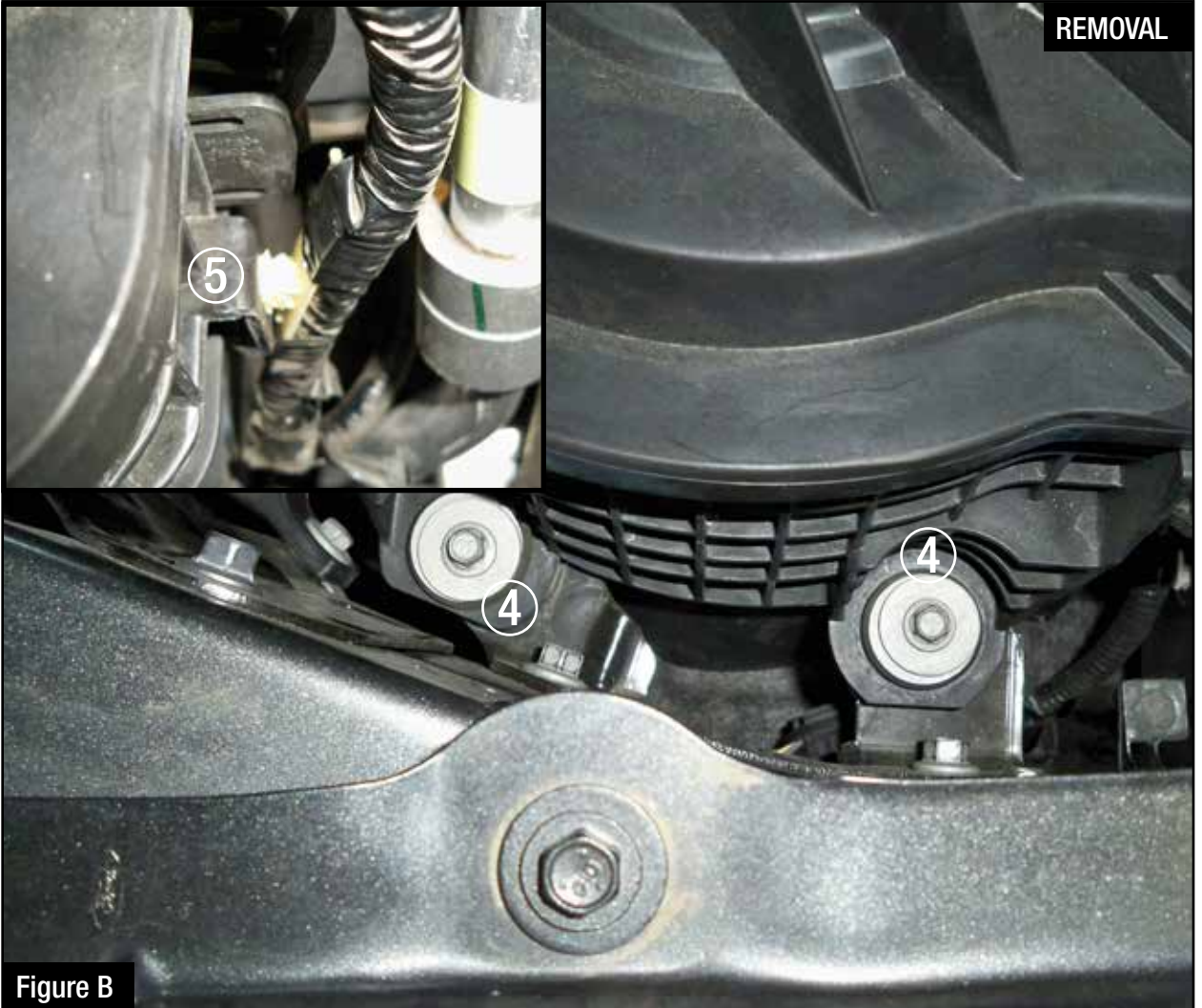

Figure B

**Refer to Figure B for Steps 2-3**

Step 2: Using a 8mm nut driver, remove the two screws (4) securing the airbox to the frame and set them aside for later use.

Step 3: Remove the wire clip (5) attached to the airbox.





Figure C

**Refer to Figure C for Steps 4-5**

Step 4: Slide back the red locking tab on the bottom side of the MAF sensor connector⑥ and then disconnect the sensor.

Step 5: Remove the OE airbox by pulling in an upward motion.



**Refer to Figure D for Step 6**

Step 6: Remove the factory grommets with metal inserts (7) from the OE airbox and install them on the aFe housing.

**Figure E****Refer to Figure E for Steps 7-8**

Step 7: Slide the aFe filter into the aFe housing. Install the aFe filter using a #3 Phillips screwdriver.  
Tighten all four screws.

Step 8: Install the supplied bellows coupling (8) onto the air filter using the supplied #80 clamp (9).  
Tighten the clamp.





Figure F

**Refer to Figure F for Step 9**

Step 9: Install the housing assembly into the vehicle by pushing it in to the factory grommet. Secure the housing assembly with the two screws (10) removed in Step 2. Tighten both screws.



INSTALL



Figure G

**Refer to Figure G for Steps 10-12**

Step 10: Remove the factory filter minder and grommet (11) and install them onto the aFe intake tube.

Step 11: Using a T20 Torx driver, remove the MAF sensor (12) from the OE airbox.

Step 12: Install the MAF sensor in the aFe intake tube using the provided M4 screws and a T20 Torx driver.

**Figure H****Refer to Figure H for Steps 13-14**

Step 13: Slide the supplied hump coupling (13) over the turbo inlet with one of the supplied #72 clamp (14). Tighten the clamp.

Step 14: Place the other provided #72 clamps (15) onto the hump coupling and onto the filter coupling.



**Figure I****Refer to Figure I for Steps 15-17**

Step 15: Slide the aFe intake tube into the coupling at the filter, then install the intake tube into the coupling at the turbo inlet. Tighten all the clamps with an 8mm nut driver.

Step 15: Reconnect the MAF sensor (16) .

Step 16: Secure the hose to the tube with the provided fixing clamp, 6mm screw and washer (17) . Using a 10mm nut driver, tighten the screw. Check all the components are tight and secure. Your installation is now complete. Thank you for choosing aFe POWER.

**NOTE: Check all bolts, clamps, and connectors after 100-200 miles.**

Page left blank intentionally





Pro DRY S Air Filter



P/N: 21-90103

Pro 5R Air Filter



P/N: 23-91132

Pro DRY S Restore Kit



P/N: 90-59999

Blue Squeeze Restore Kit



P/N: 90-50501

Intercooler Tubes



P/N: 46-20314-B

Rebel XD Series Exhaust



P/N: 49-43102-B (Blk. Tips)  
49-43102-P (Pol. Tips)

Downpipe Back Exhaust

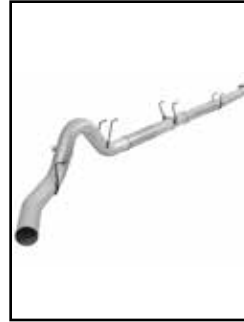

P/N: 49-03093NM

DPF-Back Exhaust



P/N: 49-03090-B (Blk. Tip)  
49-03090-P (Pol. Tip)

SCORCHER PRO Tune



P/N: 77-33006

DFS Fuel System



P/N: 42-13051 (Full-Time)  
42-13052 (Part-Time)

SCORCHER HD Module



P/N: 77-43020

Rear Differential Cover



P/N: 46-70352-WL (w/ Oil)

To purchase any of the items above, view airflow charts, dyno graphs, photos, and video; please go to [aFepower.com](http://aFepower.com).

# Warranty

## General Terms:

- aFe warrants their products to be free from manufacturer's defects due to workmanship and material.
- This warranty applies only to the original purchaser of the product and is non-transferrable.
- Proof of purchase of the aFe product is required for all warranty claims.
- Warranty is valid provided aFe instructions for installation and/or cleaning were properly followed.
- Proper maintenance with regular inspections of product is required to insure warranty coverage.
- Damage due to improper installation, abuse, unauthorized repair or alteration is not warranted.
- Incidental or consequential damages or cost, including installation and removal of part, incurred due to failure of aFe product is not covered under this warranty.
- All warranty is limited to the repair and/or replacement of the aFe part. To request Return Goods Authorization ("RGA"), email [RGA@afepower.com](mailto:RGA@afepower.com) or call (951)493-7100. Upon receipt of the RGA, you must return the product to the address provided in the RGA, freight prepaid and accompanied with a dated proof of purchase and the RGA. Upon receipt of the defective product and upon verification of proof of purchase, aFe will either repair or replace the defective product within a reasonable time, not to exceed thirty days.

<b>Product Category</b>	<b>P/N Prefix</b>	<b>Warranty duration</b>
Direct OE Replacement Filters	10, 11, 30, 31, 71, 73	Life of the vehicle
Racing Filters	18	1 year
Universal	21, 24, 72	2 years
Air Intake Systems	50, 51, 54, 55, 75	2 years
Exhaust Systems	49	2 years
Intercoolers & Intercooler Tubes	46-2	2 years
Intake Manifolds	46-1	2 years
Differential Cover	46-7	Life of the vehicle
Exhaust Manifolds	46	2 years
Throttle Body Spacers	46-3	2 years
Fluid Filters	44	90 days
Pre-Filters	28	2 years
Heavy Duty OE Replacement	70	2 years
PowerSports OE Replacement	81, 87	2 years
PowerSports Intake Systems	85	2 years

No other warranty expressed or implied applies nor is any person or advanced FLOW engineering authorized to assume any other warranty. Some States do not allow the exclusion or limitation of incidental or consequential damages or do not allow limitations on how long an implied warranty lasts, so the above limitations or exclusions may not apply to you. This warranty gives you specific legal rights, and you may also have other rights which vary from State to State.

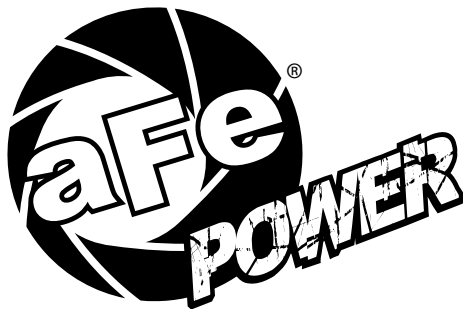

**advanced FLOW engineering, inc.**  
252 Granite Street Corona, CA 92879  
TEL: 951.493.7100 • TECH: 951.493.7134  
E-Mail: [Tech@aFepower.com](mailto:Tech@aFepower.com)