

# INSTALLATION INSTRUCTIONS



## LED Light Bar Mounts

**APPLICATION:**  
Accessory for HLR Truck Racks  
**PART NUMBER:**  
57-89035

### CONTENT

ITEM	QUANTITY	DESCRIPTION	TOOLS NEEDED
1	2	Main Bracket (Left and Right)	13mm Wrench
2	2	Top Bracket (Left and Right)	13mm Socket
3	6	M8 Flanged Nut	10mm Socket
4	6	M8 Flat Washer	Ratchet
5	6	M8 Square Head Bolt	
6	4	M6 Carriage Bolt	
7	4	M6 Hex Nut	
8	4	M6 Split Lock Washer	
9	4	M6 Flat Washer	

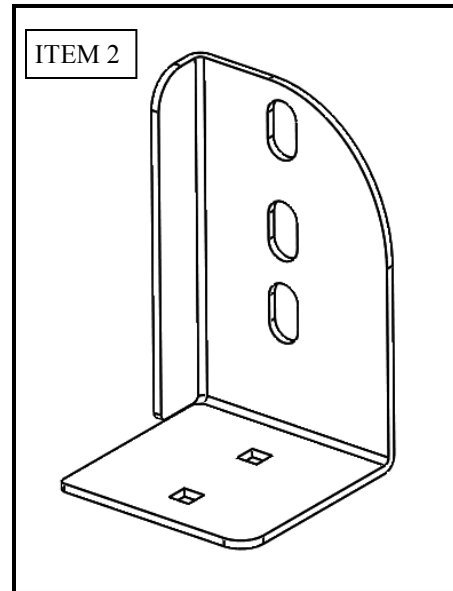
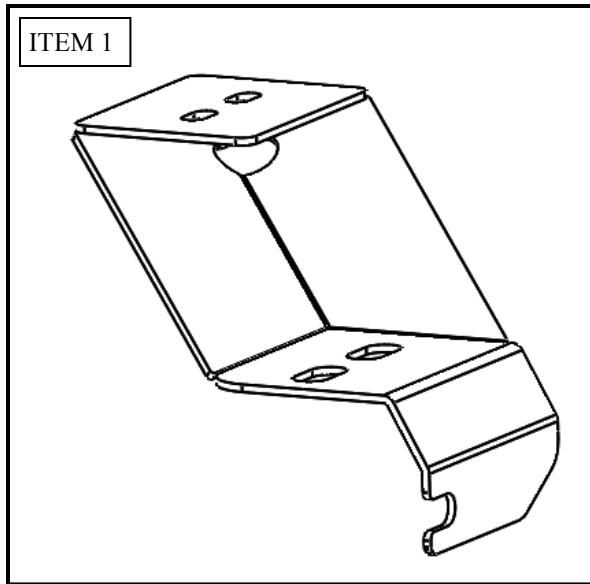

### PROCEDURE

1. Remove contents from box, verify if all parts listed are present and free from damage.  
Carefully read and understand all instructions before attempting installation.  
**Failure to identify damage before installation could lead to a rejection of any claim.**

FIGURE 1

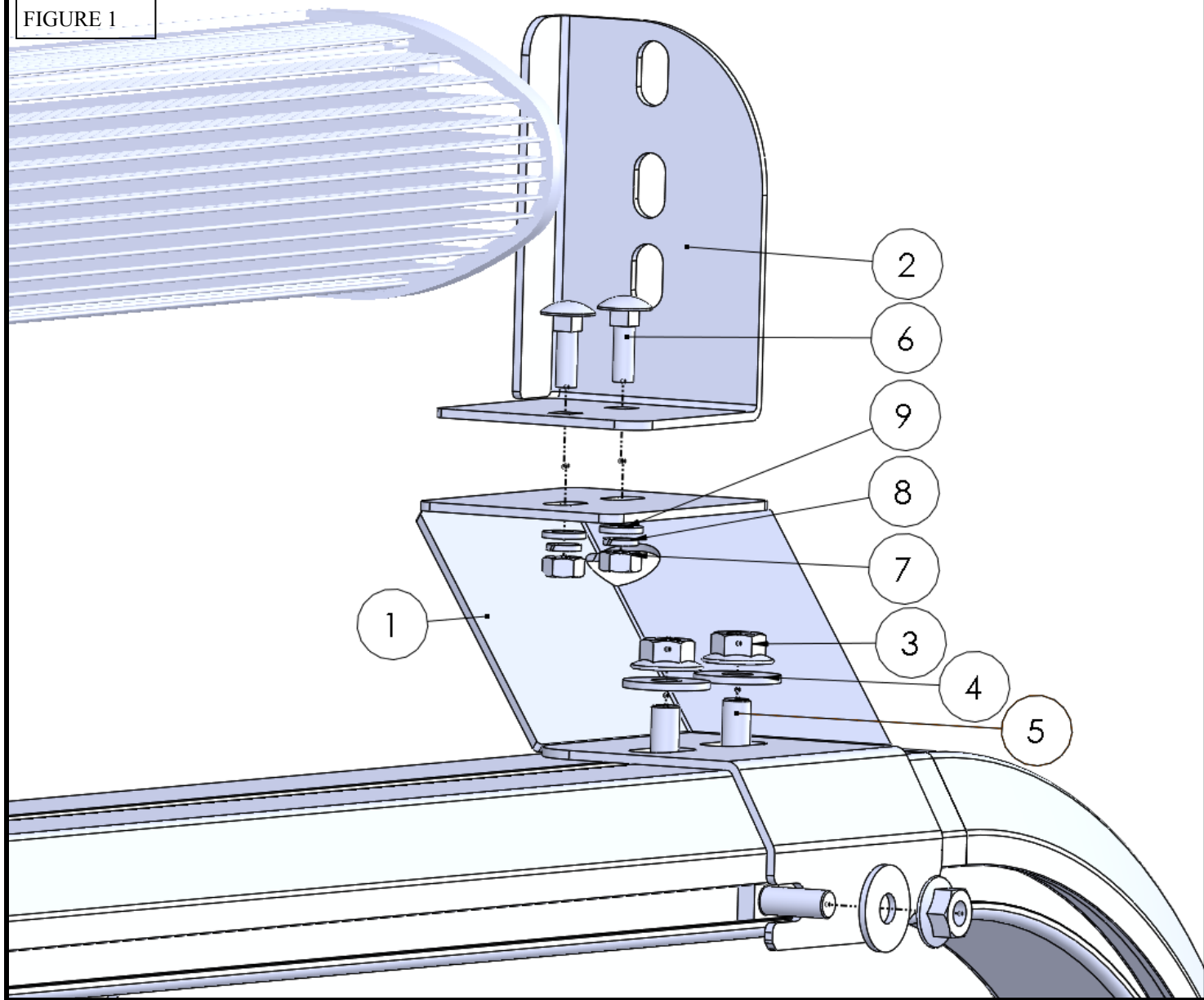

2. Position brackets according to Figure 1.
3. Assemble using supplied hardware according to Figure 1.
4. Torque M6 hardware to 5-7 ft-lbs and M8 hardware to 15-18 ft-lbs.

Note:  
These brackets can be installed in different configurations in order to accommodate various light bar lengths.

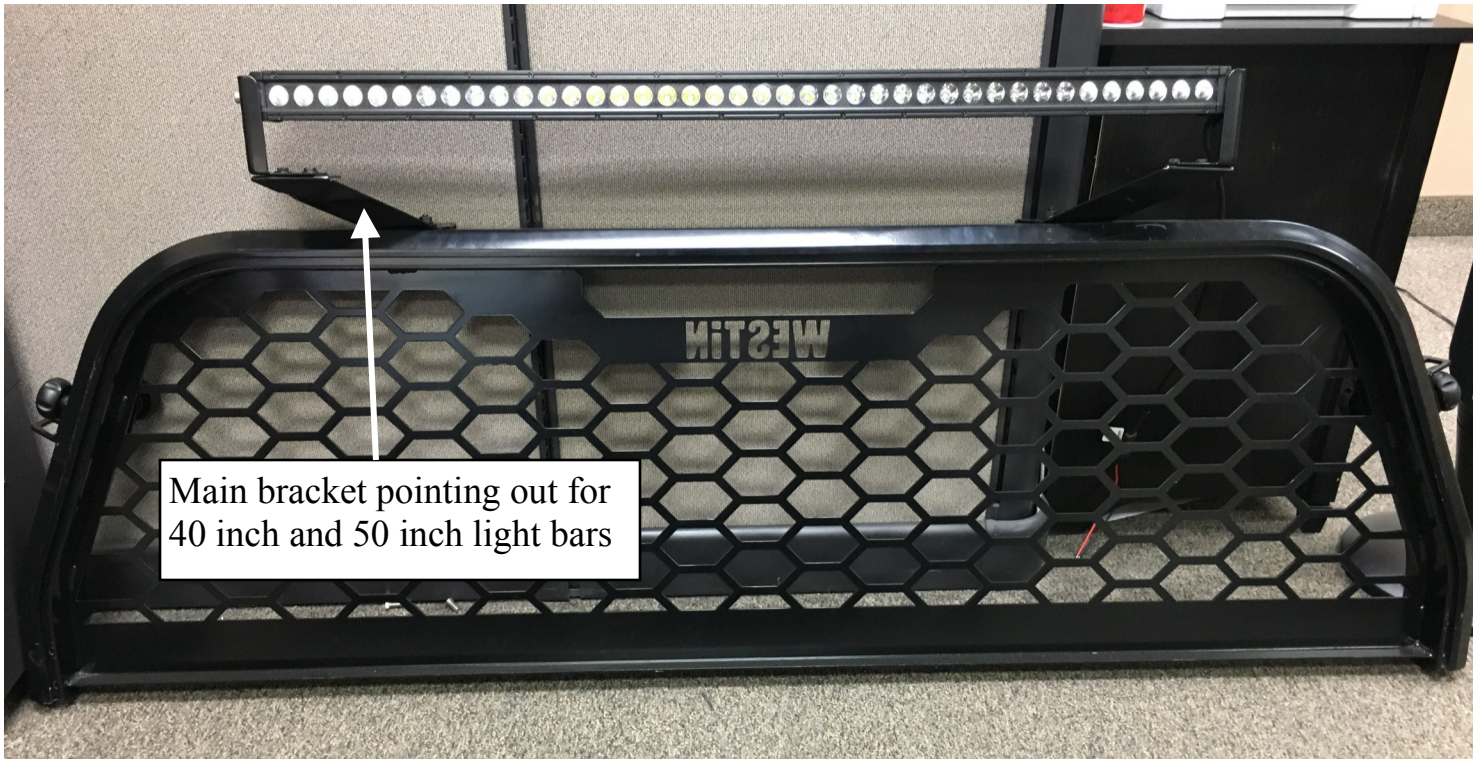

Main bracket pointing out for 40 inch and 50 inch light bars



Main bracket pointing in for all light bar lengths except 50 inch light bars

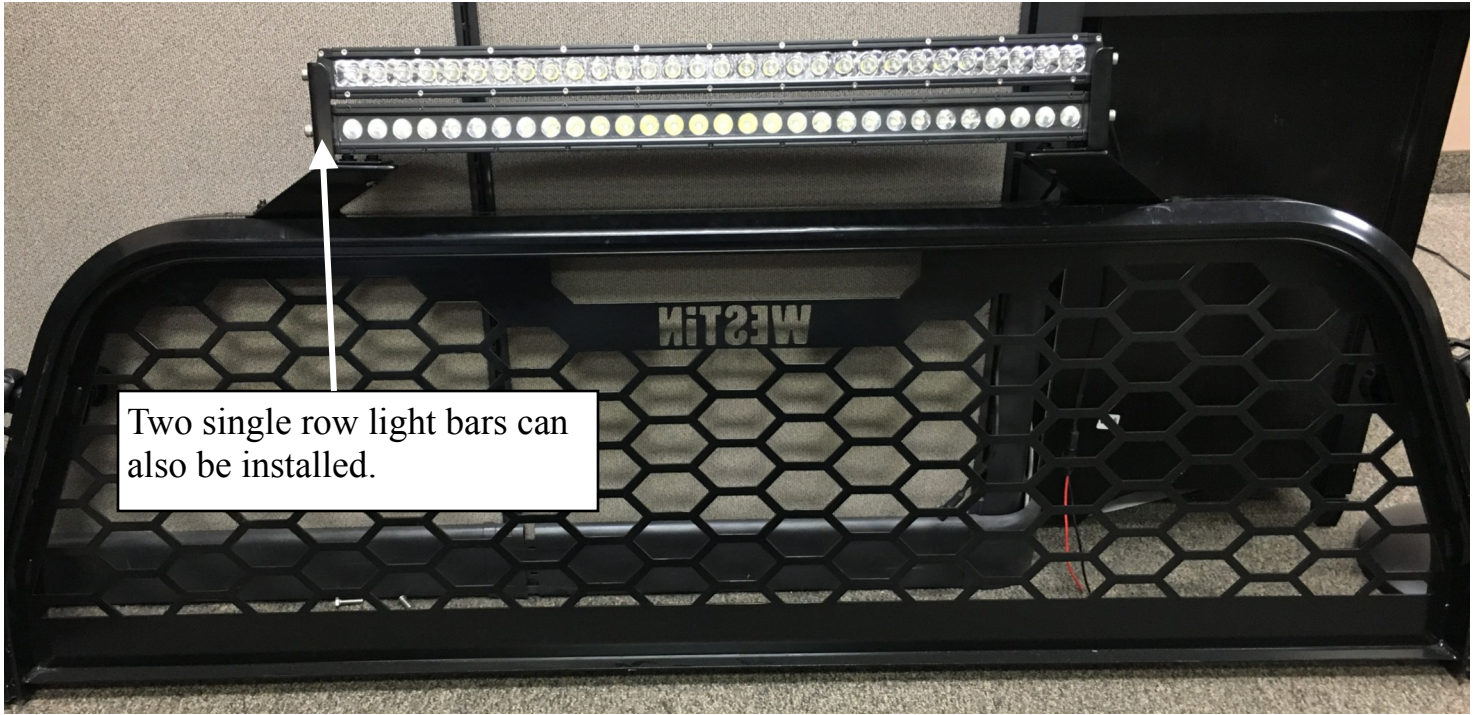

**WESTIN** Westin Automotive Products, Inc.  
320 W. Covina Blvd  
San Dimas, Ca. 91773

P.N.: 75-578903-RevA

ECO #: W18-0042

4

Thank you for choosing Westin products  
for additional installation assistance please call  
Customer Service (800) 793-7846  
[www.westinautomotive.com](http://www.westinautomotive.com)

DATE: 06/18/18

# Installation Complete



**WESTIN** Westin Automotive Products, Inc.  
320 W. Covina Blvd  
San Dimas, Ca. 91773

P.N.: 75-578903-RevA

ECO #: W18-0042

5

Thank you for choosing Westin products  
for additional installation assistance please call  
Customer Service (800) 793-7846  
[www.westinautomotive.com](http://www.westinautomotive.com)

DATE: 06/18/18



## WARNING



Failure to follow these instructions could lead to death, personal injury, and / or property damage.

Failure to follow these instructions could lead to death, personal injury, and / or property damage.

### FASTENERS:

All Westin supplied fasteners must be utilized and installed in accordance with the installation instructions and apply torque to the specifications as defined. **DOUBLE CHECK ALL FASTENERS BEFORE INITIAL USE, AND PERIODICALLY IN THE FUTURE TO ENSURE PROPER FUNCTION AND SAFETY.**

### DRILLING:

Most Westin products do not require drilling for installation. If drilling is defined as required, use caution when drilling a vehicle. **FAILURE TO REVIEW AN AREA TO BE DRILLED MAY RESULT IN PERSONAL INJURY AND/OR INJURY TO OTHERS AS WELL AS VEHICLE DAMAGE.**

### EYE PROTECTION:

**ALWAYS WEAR SAFETY GLASSES OR GOGGLES DURING THE INSTALLATION PROCESS TO AVOID PERSONAL INJURY.**

### MAXIMUM TOWING/CARRYING CAPACITY:

The Westin Receiver Hitches will have a visible tow rating label affixed directly on the product. User should never exceed the vehicle manufacturers maximum tow and weight rating regardless of the capacity of the hitch. **FAILURE TO FOLLOW THESE GUIDELINES WILL VOID THE WESTIN WARRANTY AND MAY RESULT IN PERSONAL INJURY AND/OR INJURY TO OTHERS AS WELL AS VEHICLE DAMAGE.**



Westin Automotive Products, Inc.  
320 W. Covina Blvd  
San Dimas, Ca. 91773