

13303 Installation Instructions

WARNING!

The fuel system is under pressure. Do not open the fuel system until the pressure has been relieved. Refer to the appropriate vehicle service manual for the procedure and precautions for relieving the fuel system pressure.

NOTE: The enclosed regulator will not necessarily seal to hold fuel pressure after the fuel pump stops running. In addition, testing the enclosed regulator by applying air pressure or vacuum to the vacuum/boost port with a hand-held pump will show a slight air leakage through the adjustment screw threads. This leakage is minute and is typical of all adjustable fuel pressure regulators. This does not, in any way, affect the performance of this regulator.

The Aeromotive X1 Regulator, Part #13303, utilizes two o-ring sealed ORB-08 inlet/outlet ports and one o-ring sealed ORB-08 style bypass or return port. Aeromotive offers port adapters fittings suitable for adapting these ports to AN-06, AN-08 and AN-10 line (see instructions for part #s).

ORB ports are **NOT PIPE THREAD** and utilize **NO THREAD SEALANT**. You must install ORB port fittings with o-rings, high pressure fuel lines and/or fuel injector rails to use this regulator. Each regulator has one 1/8" NPT gauge port which does requires thread sealant to seal.

CAUTION:

Installation of this product requires detailed knowledge of automotive systems and repair procedures. We recommend that this installation be carried out by a qualified automotive technician.

Installation of this product requires handling of gasoline. Ensure you are working in a well ventilated area with an approved fire extinguisher nearby. Extinguish all open flames, prohibit smoking and eliminate all sources of ignition in the area of the vehicle before proceeding with the installation.

When installing this product, wear eye goggles and other safety apparel as needed to protect yourself from debris and sprayed gasoline.

This regulator features a 1/16" NPT vacuum/boost reference port which, when connected to manifold pressure will raise fuel pressure with boost and reduce it with vacuum. It works on a ratio of 1:1 with PSI. If unused, please do not plug, leave the nipple open to atmosphere. If necessary, a bronze filter adapter fitting is available for extreme environments under P/N 15662.

Base Adjustment Range:	35-75 PSI
Boost reference range:	Limited only by pump capability.
Max Fuel Flow Range:	Up to 150 GPH (900 lb/hr or 550 LPH)

Aeromotive system components are not legal for sale or use on emission controlled motor vehicles. The following steps are typical of most installations:

1. Once the engine has been allowed to cool, disconnect the negative battery cable and relieve the fuel system pressure.
2. Remove any cosmetic covers necessary to allow access to the fuel pressure regulator.
3. Remove the vacuum line from the regulator (some vehicles do not have vacuum operated regulators).
4. Place shop towels around the regulator to catch any gasoline that is spilled during this step of the installation. Remove any regulator mounting hardware and connecting fuel lines, then carefully remove the regulator.
5. Find a suitable place in the vehicle's engine compartment to mount the Aeromotive regulator. Using the supplied mounting bracket as a template, mark the bracket mounting holes and drill to accept a #10 screw.
6. Remove the bracket from the regulator and mount it to the vehicle using two #10 screws, nuts and lock washers. Once the bracket is mounted, reattach the regulator to the bracket with the supplied socket head cap screws and lock washers.
7. Attach the fuel line(s) from the fuel rail outlet port(s) to the regulator **side** ports using AN-08 style fittings and o-rings. If only one inlet/outlet port is required (see figure 1-3 below) install an AN-08 style port plug with o-ring into the unused port.

Suggested Inlet/Outlet Port Fittings:

ORB-08 to AN-06 – P/N 15605
ORB-08 to AN-08 – P/N 15607
ORB-08 to AN-10 – P/N 15641
ORB-08 Port Plug – P/N 15618
ORB-08 Port Plug with
1/8" NPT gauge port – P/N 15637

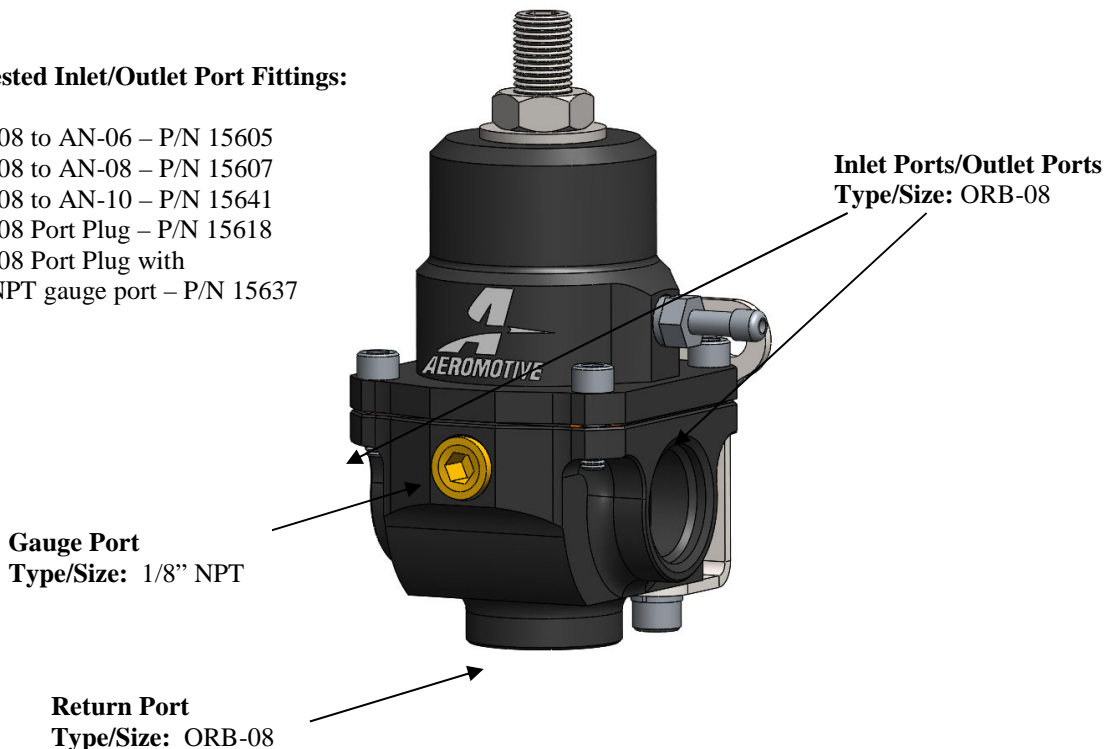

8. Attach the fuel return line to the regulator return port located on the **bottom** of the regulator, using an AN-08 style fitting and o-ring. Tighten all connections.

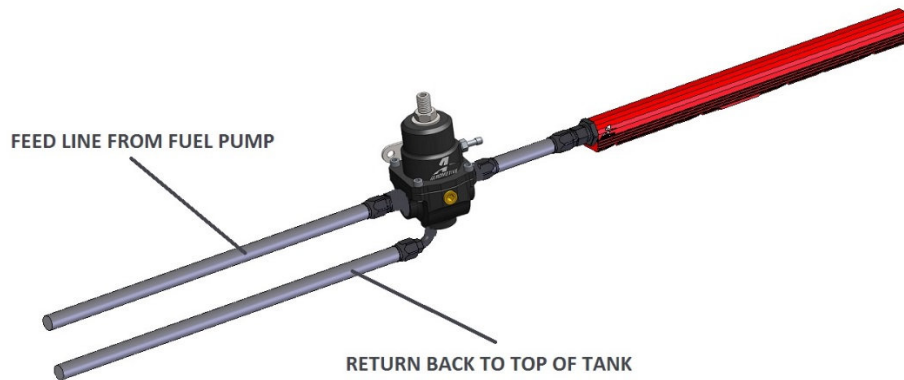
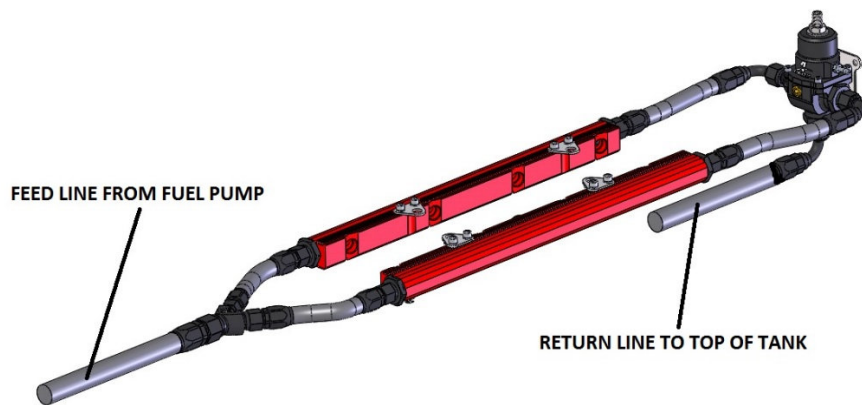

FIGURE 1-1

9. Figure 1-1 depicts a “returnless” fuel rail with only one fuel line connection, as commonly used by the factory on late model fuel systems beginning in 1999. Positioning the regulator after the fuel rail is recommended for performance applications, however your new Aeromotive return-style regulator may be configured for a “returnless” type of engine/fuel rail as well. This is done by flowing into one of the regulator side ports from the pump and out of the opposite side port into the fuel rail inlet. Note: a return line **MUST STILL** be routed from from the bottom (return) port back to the top of the fuel tank.



FIGURE

Figure 1-2 is optimum for performance V8 engines with dual fuel rails, offering both inlet and outlet ports.

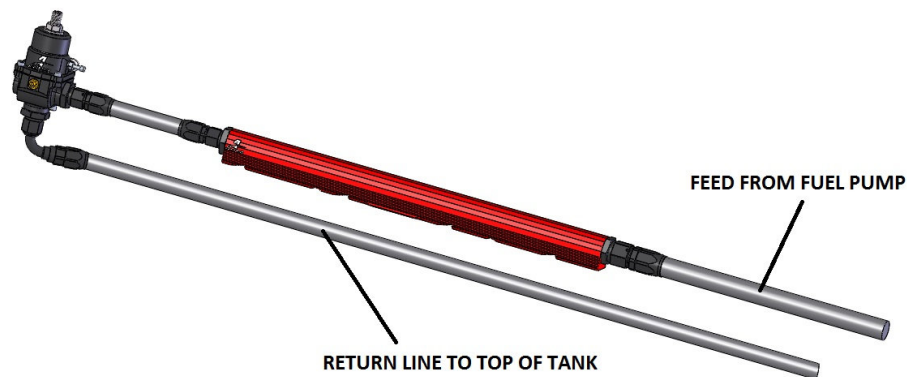

FIGURE 1-

Figure 1-3 places the regulator after the fuel rail and is the optimum plumbing approach for single rail fuel rail applications equipped with both inlet and outlet ports.

10. Once the regulator is installed, attach a suitable fuel pressure gauge to the 1/8 NPT port on the fuel pressure regulator (0-100psi 1.5" fuel pressure gauge, part # 15633). Requires thread sealant.
11. **Ensure that any spilled gasoline and any gasoline soaked shop towels are cleaned up and removed from the vicinity of the vehicle!**
12. Reconnect the battery and turn the ignition to the ON position **WITHOUT** starting the car. After several seconds, check the fuel pressure. If there is no fuel pressure, turn the ignition key to the OFF position, wait one minute, return the ignition to the ON position, and recheck the fuel pressure. Repeat this ignition OFF and ON procedure until the fuel pressure gauge registers fuel pressure.
13. **With the fuel pressure gauge registering fuel system pressure, check for fuel leaks from and around the Aeromotive regulator. If any fuel leaks are found, turn the ignition key to the OFF position, remove any spilled fuel and repair the leak before proceeding!**
14. Once the fuel pressure gauge registers fuel system pressure and there are no fuel leaks, disconnect the vacuum/boost line, start the engine and adjust the regulator to the desired fuel pressure. Turning the adjustment screw clockwise will increase fuel pressure. OEM EFI return style engines run at approximately 43 psi vacuum off, returnless engines at 60 psi, vacuum off. The base pressure adjustment range is from 35-75 psi. Boost reference pressure is over and above base pressure.
15. Once the desired fuel pressure is achieved, tighten the regulator adjustment jam nut and attach the vacuum line if one is being used. If the vehicle is not equipped with a vacuum line, leave vacuum port open to atmosphere. Blocking the vacuum port will yield poor regulator performance. If vacuum port fitting becomes lost or broken replacement fittings can be purchased (part # 15630).
16. If you do not want to keep the fuel pressure gauge on the vehicle, relieve the fuel system pressure as instructed in the appropriate vehicle service manual and remove the fuel pressure gauge.

17. Test drive the car to insure proper operation and re-check the fuel system for leaks. **If any leaks are found, immediately shut off the engine and repair the leak(s)!**

Special Features of the X1 Regulator P/N 13303

The 13303 is engineered for flexibility, featuring an interchangeable Poppet Seat, Diaphragm/Poppet and Spring assembly. Installing any of the optional kits allows the X1 Regulator to be re-configured for a wide array of pressure ranges and fuel pump flow capacities. Figure 1-4 is an exploded view of the regulator to aid in identifying the various components. The following part #'s are the interchange kits available:

13013 - .188" Poppet Seat (RED) with 35-75psi: Up to 150 GPH return flow

13014 - .313" Poppet Seat (BLACK) with 3-20psi Up to 250 GPH return flow

13015 - .313" Poppet Seat (BLACK) with 35-75psi Up to 300 GPH return flow

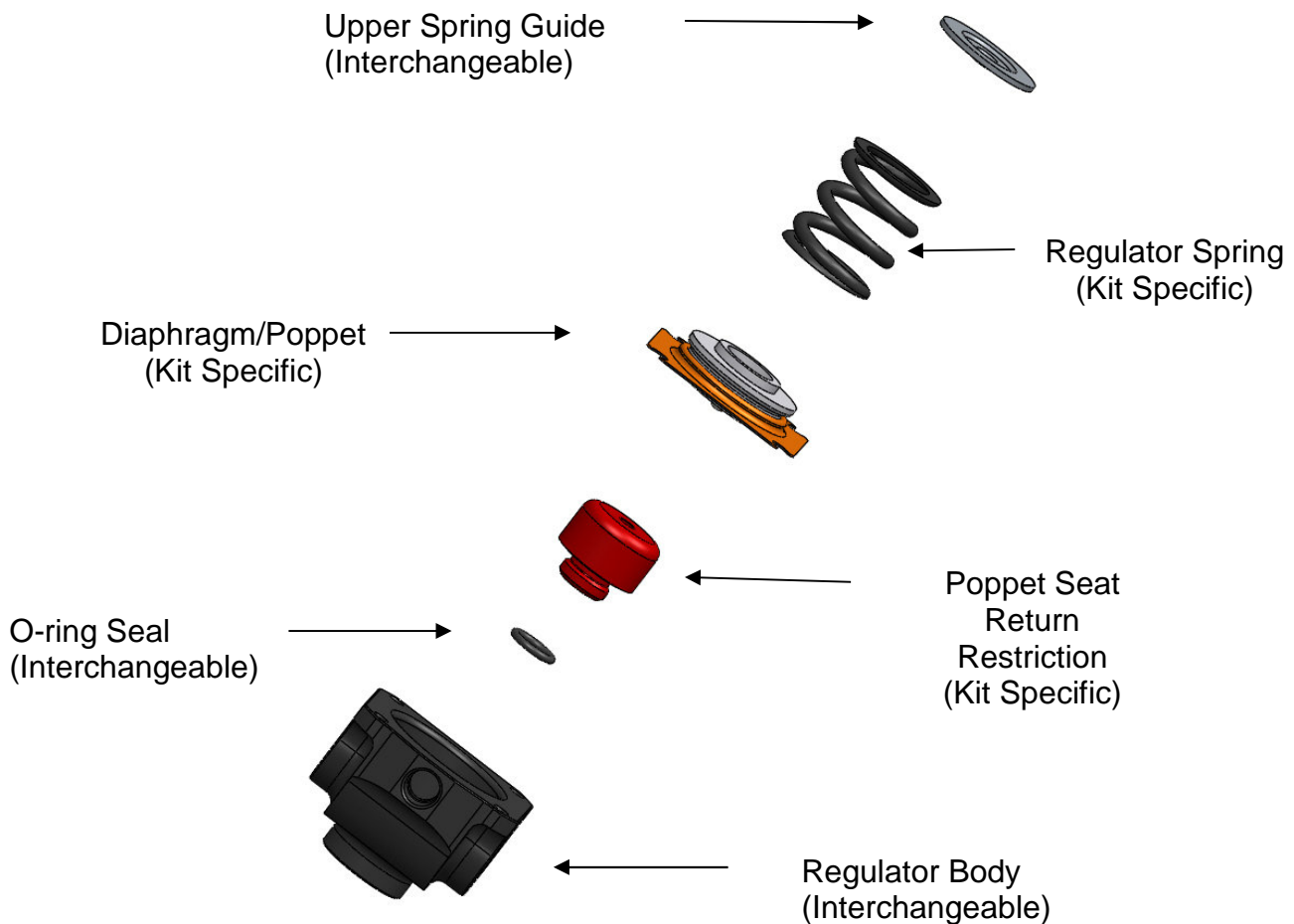

FIGURE 1-4



WARNING: This product can expose you to chemicals, including chromium, which is known to the State of California to cause cancer or birth defects or other reproductive harm. For more information, visit: www.p65Warnings.ca.gov

AEROMOTIVE, INC. LIMITED WARRANTY

This Aeromotive Product, with proof of purchase dated on or after January 1, 2003, is warranted to be free from defects in materials and workmanship for a period of one year from the original date of purchase. No warranty claim will be valid without authentic, dated proof of purchase.

This warranty is to the original retail purchaser and none other and is available directly from Aeromotive and not through any point of distribution or purchase.

If a defect is suspected, the retail purchaser must contact Aeromotive directly to discuss the problem, possible solutions and obtain a Return Goods Authorization (RGA), if deemed necessary by the company. Please call 913-647-7300 and dial option 3 for the technical service dept. All returns must be shipped freight pre-paid to the company and with valid RGA before they will be processed.

Aeromotive will examine any product returned with the proper authorization to determine if the failure resulted from a defect or from abuse, improper installation, misapplication or alteration. Aeromotive will then, at it's sole discretion, return, repair or replace the product.

If any Aeromotive product is determined defective, buyer's exclusive remedy is limited in value to the sale price of the good. In no event shall Aeromotive be liable for incidental or consequential damages.

Aeromotive expressly retains the right to make changes and improvements in any product it manufactures and sells at any time. These changes and improvements may be made without notice at any time and without any obligation to change the catalogs or printed materials.

Aeromotive expressly retains the right to discontinue at any time and without notice any Aeromotive product that it manufactures or sells.

This warranty is limited and expressly limits any implied warranty to one year from the date of the original retail purchase on all Aeromotive products.

No person, party or corporate entity other than Aeromotive shall have the right to: determine whether or not this Limited Warranty is applicable to any Aeromotive product, authorize any action whatsoever under the terms and conditions of this Limited Warranty, assume any obligation or liability of any nature whatsoever on behalf of Aeromotive under the terms and conditions of this Limited Warranty.

This Limited Warranty covers only the product itself and not the cost of installation or removal.

This Limited Warranty is in lieu of and expressly excludes any and all other warranties, expressed or implied. This Limited Warranty gives you specific legal rights, and you may also have other rights which vary from state to state.