

Installation Instructions

I - Sheet Number BF134 Rev.A



Bugflector® - Bugflector II® - Carflector® - Chrome Hood Shield™

For proper installation and best possible fit, please read all instructions BEFORE you begin.
For technical assistance or to obtain missing parts, please call Customer Relations at 1-800-241-7219.

Important Safety Information



- CAUTION - Before driving, ensure that the hood shield is properly secured to vehicle.
- Do not use automatic "brush-style" car washes.
- Do not use cleaning solvents of any kind.
- Periodically check all components for tightness.

Contents

NOTE: Actual product may vary from illustration.

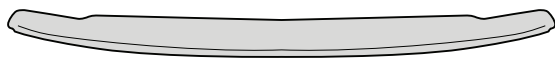

Hood shield



Alcohol pad x2



Self Tapping screw x4

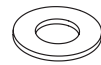

Aluminium Flat Washer x4



Bump On x4
(98024)

Tools Required



Car Wash Supplies



Clean Towel

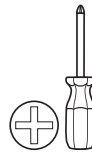

Phillips
screwdriver

Preparation Before Painting / Installation

- A trial fit is recommended to ensure proper positioning and fit.
- Check fit of parts before painting as we will not accept the return of modified or painted parts.
- Wash and dry your vehicle to remove any debris and/or dirt from the installation area.

Installation Steps

NOTE: Actual application may vary slightly from illustrations.

Open hood.

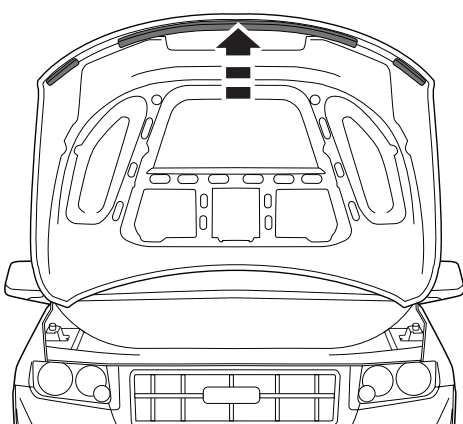

1

Remove (4) plastic seal retaining fasteners that align with the pre-drilled holes and tabs in the hood shield. Next, carefully separate the hood seal / gasket from the areas of the hood that align with the hood shield tabs.

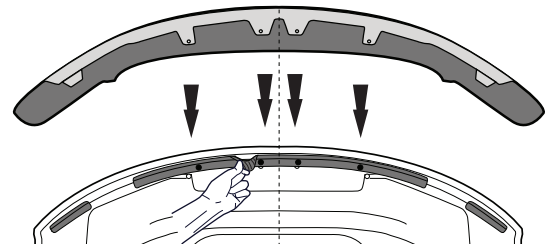

2



NOTE: Exercise extreme caution not to tear or damage the hood seal / gasket when separating from hood.

Installation Steps

NOTE: Actual application may vary slightly from illustrations.

Alcohol Pad

Use an alcohol pad to clean the hood surface underneath the OUTBOARD rubber trim pieces.

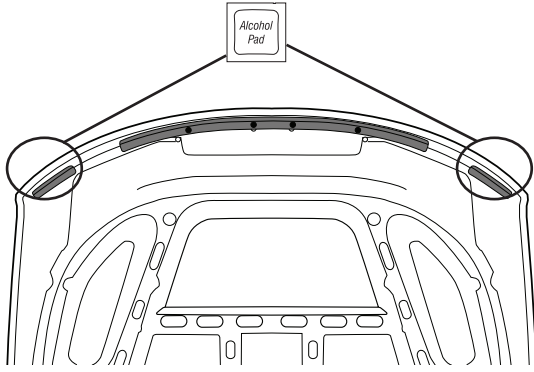

Remove red tape liners from both OUTBOARD tabs of hood shield.

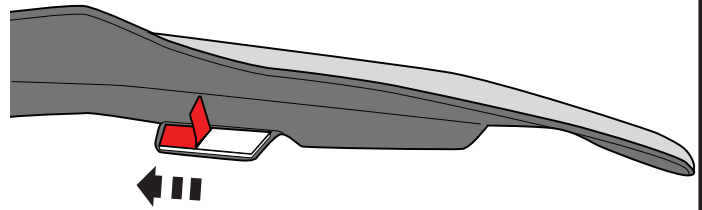

Reposition the hood shield with the tabs sliding between the hood and rubber seal and align with holes.

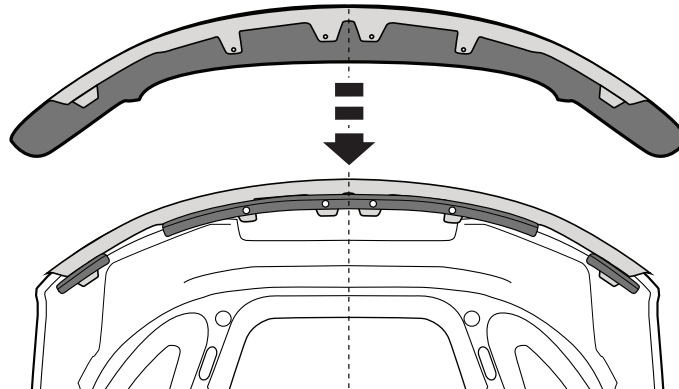

Insert (4) screws and washers through the rubber gasket, hood shield, and into the hood. Securely tighten.

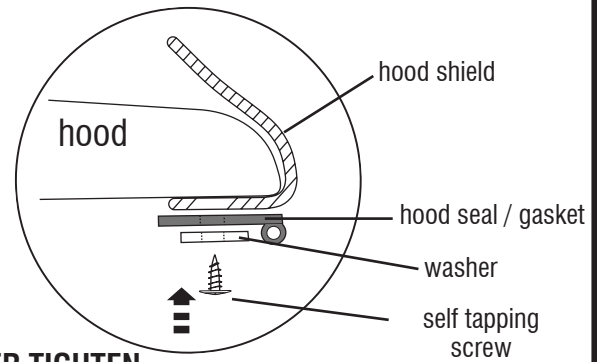
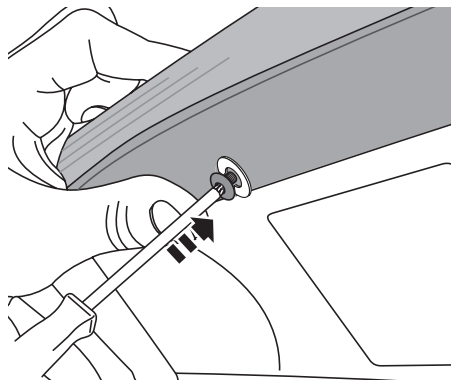

DO NOT OVER TIGHTEN

Apply firm pressure to OUTBOARD tabs to ensure adhesion of tape to hood surface.

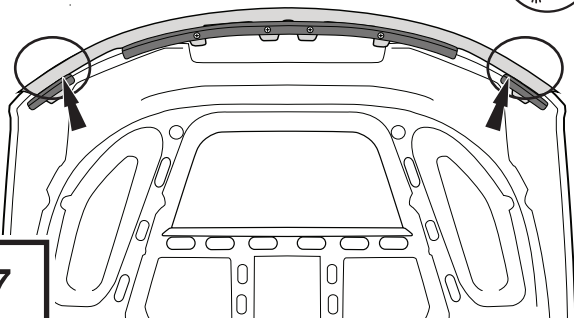

Turn both of the hood bumpers counter clockwise 1 1/2 turns.

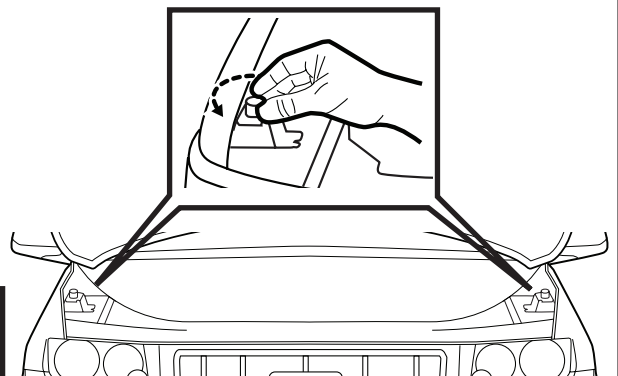

Installation Steps **NOTE:** Actual application may vary slightly from illustrations.

Close Hood.

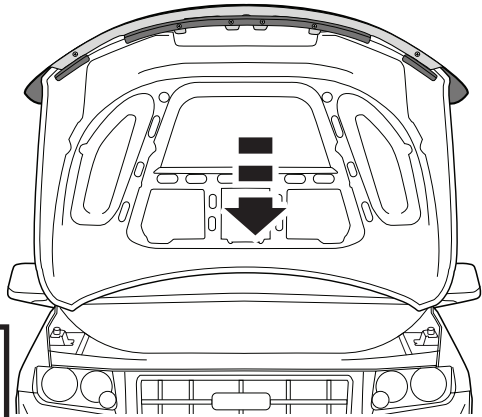

9



Apply (4) bump ons to surface of hood.

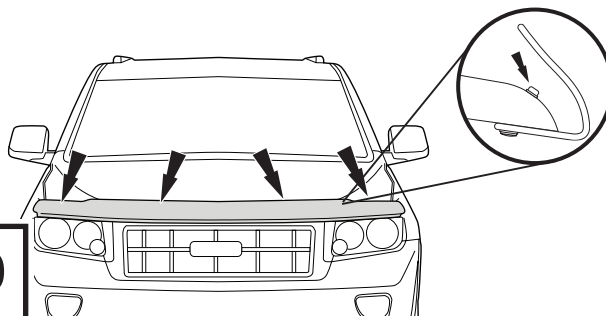

10

Care and Cleaning

- Wash only with mild soap & dry with a clean cloth.



The material that your product is made from can be recycled. Please also consider recycling the packaging that your product came in.



Congratulations!

You have purchased one of the many quality Auto Ventshade™ branded products offered by Lund International. We take the utmost pride in our products and want you to enjoy years of satisfaction from your investment. We have made every effort to ensure that your product is top quality in terms of fit, durability, finish and ease of installation.



Lund International

800-241-7219 • Visit us at lundinternational.com

© 2020 Lund, Inc. All rights reserved.

Auto Ventshade™, the Auto Ventshade™ logo and the AVS™ logo are trademarks of Lund, Inc.





Bugflector® - Bugflector II® - Carflector® - Chrome Hood Shield™

Pour obtenir une installation correcte et le meilleur ajustement possible, lire toutes les instructions AVANT de commencer.
 Pour toute assistance technique ou obtention de pièces manquantes, appeler le service des relations avec la clientèle au 1-800-241-7219.

Informations importantes concernant la sécurité



- ATTENTION – Avant de conduire, s'assurer que le pare-insectes est solidement assujettie sur le véhicule.
- Ne pas utiliser les stations de lavage de voitures à brosse.
- Ne pas utiliser de solvants.
- Vérifier régulièrement le serrage des composants.

Contenu

REMARQUE : Le produit réel peut différer du modèle illustré.



Protection de capot



2 tampons d'alcool



4 Vis autota-raudeuse

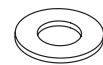

4 Aluminium rondelle plate



4 gommes (98024)

Outils nécessaires



Équipement de nettoyage



Linge propre



Tournevis Phillips

Préparation pour la peinture/l'installation

- Il est recommandé de procéder à un essai pour s'assurer que le positionnement et l'ajustement sont corrects.
- Vérifier l'ajustement des pièces avant peinture, car nous n'acceptons pas le retour de pièces modifiées ou peintes.
- Laver les glissières de glaces de la portière du véhicule pour éliminer toute poussière et tous débris.
- Sécher les glissières avec une serviette propre.

Étapes de l'installation

REMARQUE : L'installation réelle peut différer légèrement des illustrations.

Ouvrez le capot.

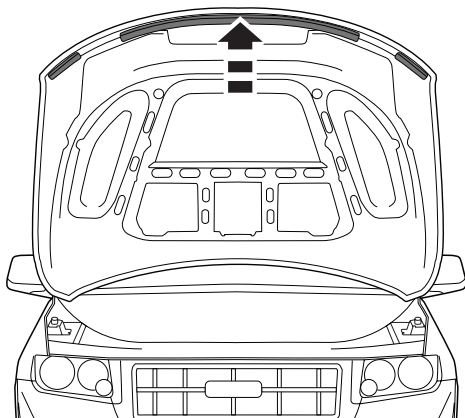

1

Retirez les (4) attaches de retenue du joint en plastique qui s'alignent avec les trous et les languettes pré-percés dans la protection de la hotte. Ensuite, séparez soigneusement le joint / joint de la hotte des zones de la hotte qui s'alignent avec la bride de protection de la hotte.

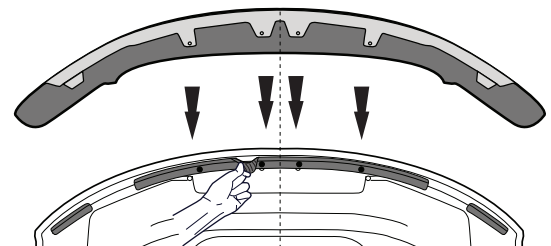

2



REMARQUE: Faites preuve de prudence extrême à ne pas déchirer ou endommager le capot d'étanchéité / joint lors de la séparation du capot.

Étapes d'installation

REMARQUE : La méthode d'application peut être légèrement différente de celle représentée par les illustrations.

Alcohol Pad

Utilisez un tampon imbibé d'alcool pour nettoyer la surface de la hotte sous les pièces de garniture en caoutchouc HORS-BORD.

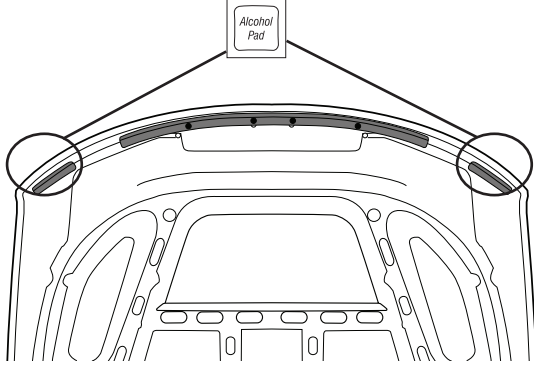

3

Retirez les doublures de ruban rouge des deux languettes HORS-BORD du bouclier de capot.

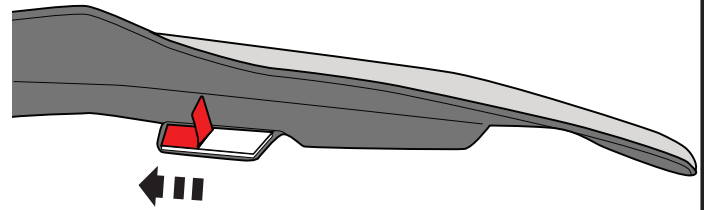

4

Repositionnez la protection de la hotte avec les languettes couissant entre la hotte et le joint en caoutchouc et alignez-les avec les trous.

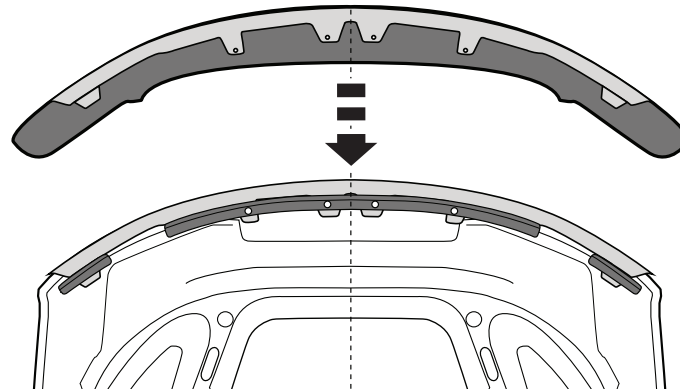

5



Insérez (4) vis et rondelles dans le joint en caoutchouc, le bouclier de capot et dans la hotte. Serrez fermement.

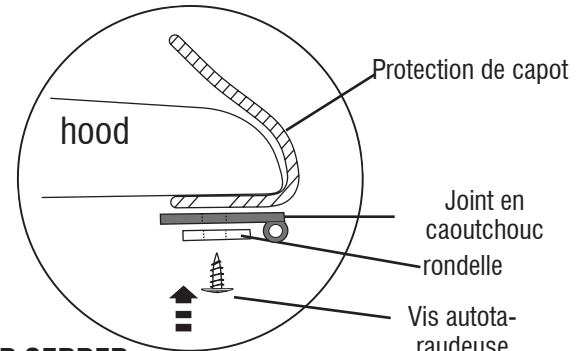
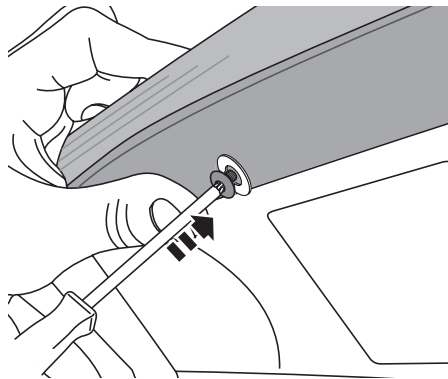

6

NE PAS TROP SERRER

Appliquez une pression ferme sur les languettes HORS-BORD pour assurer l'adhérence du ruban à la surface de la hotte.

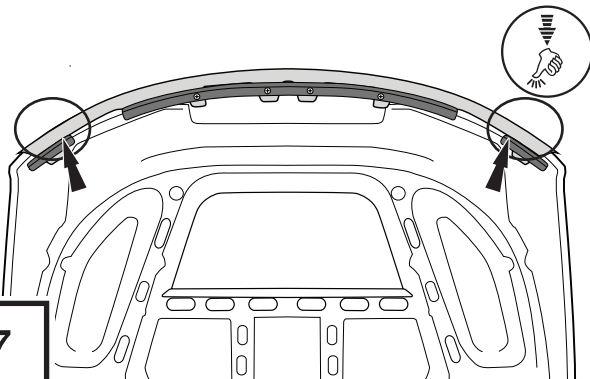

7

Tournez les deux pare-chocs de la hotte dans le sens antihoraire 1 1 / 2 tours.

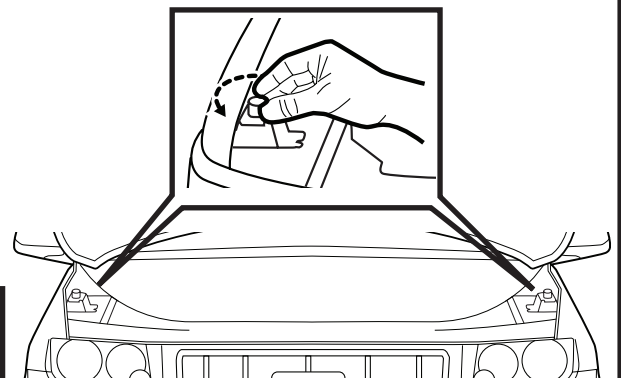

8

Étapes d'installation

REMARQUE : La méthode d'application peut être légèrement différente de celle représentée par les illustrations.

Fermer le capot.

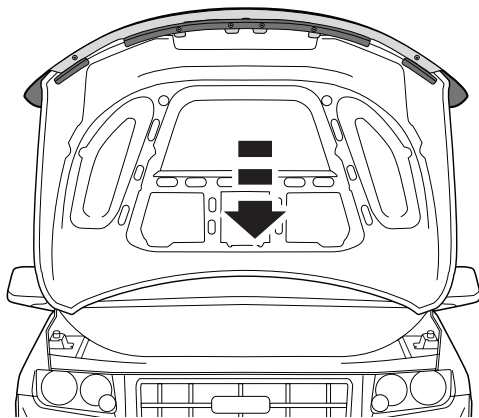

9



Appliquer (4) les butoirs sur le capot.

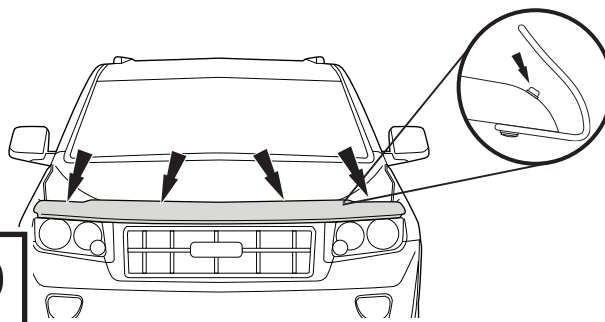

10

Entretien et nettoyage

- Laver exclusivement avec de l'eau savonneuse et sécher avec un chiffon propre.



Le matériau à partir duquel votre produit est fabriqué est recyclable. Pensez également à recycler l'emballage dans lequel votre produit a été livré.



Félicitations !

Vous avez acheté l'un des nombreux produits de qualité Auto Ventshade™ fabriqués par Lund International. Nous sommes extrêmement fiers de nos produits et souhaitons que vous tiriez des années de satisfaction de votre investissement. Nous avons pris toutes les mesures nécessaires pour assurer que ce produit est d'une qualité supérieure en ce qui concerne l'ajustement, la durabilité, la finition et la facilité d'installation.



Lund International

800-241-7219 • Visitez notre site lundinternational.com

© 2020 Lund, Inc. Tous droits réservés.

Auto Ventshade™, le logo Auto Ventshade™ et le logo AVS™ sont des marques déposées Lund, Inc.





Bugflector® - Bugflector II® - Carflector® - Chrome Hood Shield™

Para una instalación adecuada y el mejor ajuste posible, lea todas las instrucciones ANTES de comenzar. Si desea recibir asistencia técnica u obtener piezas faltantes, llame al Servicio al cliente al 1-800-241-7219.

Información importante de seguridad



- PRECAUCIÓN - Antes de conducir, asegúrese de que la visera deflectora esté correctamente anclada al vehículo.
- No utilice servicios automáticos de limpieza de vehículos que utilizan cepillos.
- No utilice limpiadores al solvente de ningún tipo.
- Compruebe periódicamente que todos los componentes estén ajustados.

Contenidos

NOTA: El producto real tal vez no sea igual a la ilustración.



Cubierta del capó



Paños con alcohol x 2



Tornillo penetrante x4



Arandela plana
Aluminio x4



Topes de goma x 4
(98024)

Herramientas necesarias



Equipo de limpieza de
vehículos

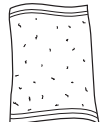

Toalla limpia



Destornillador
Phillips

Preparación antes de pintar o instalar

- Se recomienda realizar un ajuste de prueba para asegurar el posicionamiento y ajuste correctos.
- Compruebe que las piezas se ajusten correctamente antes de pintarlas, ya que no aceptaremos la devolución de piezas modificadas o pintadas.
- Lave los canales de la ventanilla del vehículo para quitar los desechos y la suciedad.
- Seque los canales de la ventanilla con una toalla limpia.

Pasos de instalación

NOTA: La aplicación real puede variar levemente con respecto a las ilustraciones.

Abra el capó.

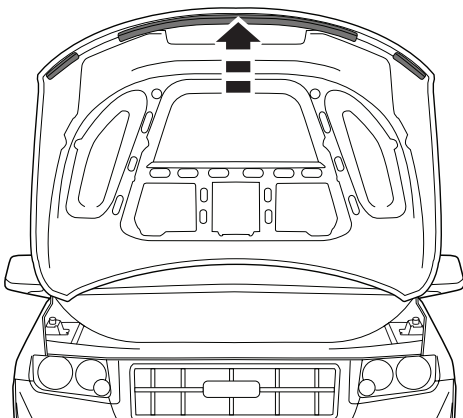

1

2

Quite los (4) sujetadores de retención del sello de plástico que se alinean con los orificios perforados previamente y las lengüetas en el protector del capó. A continuación, separe con cuidado el sello / junta de la campana de las áreas de la campana que se alinean con la brida del escudo de la campana.

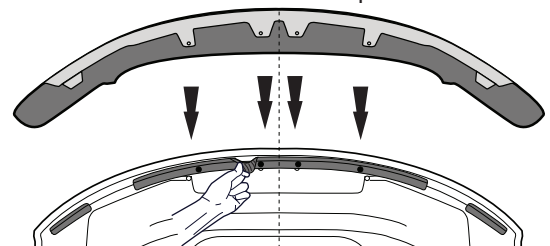

NOTA: Tenga precaución extrema de no romper o dañar la cubierta de sello / junta al separarse de la capucha.

Pasos de instalación

NOTA: El uso real puede variar levemente de ilustraciones.

Alcohol Pad

Use una gasa con alcohol para limpiar la superficie de la campana debajo de las piezas de goma del FUERABORDA.

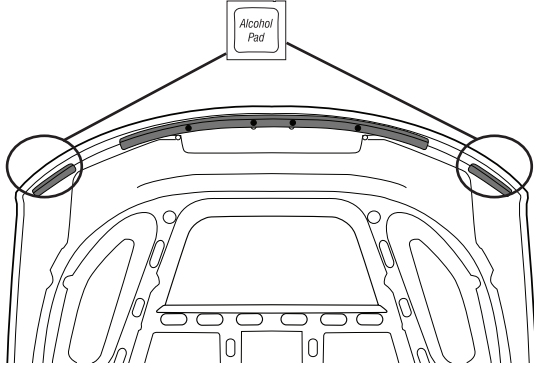

Retire los revestimientos de cinta roja de ambas pestañas EXTERIORES del protector del capó.

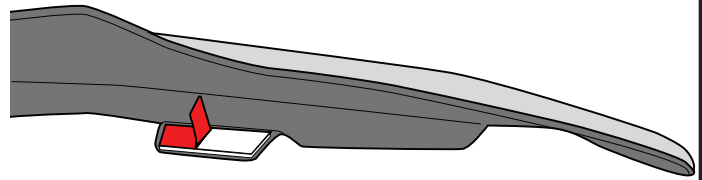

Vuelva a colocar el protector de la campana con las pestañas deslizándose entre la campana y el sello de goma y alinee con los orificios.

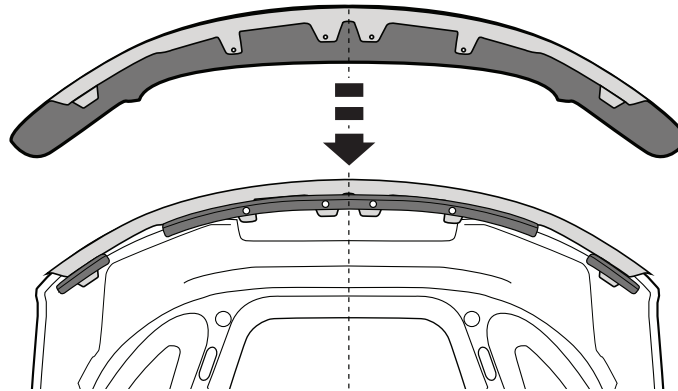

Inserte (4) tornillos y arandelas a través de la junta de goma, el protector del capó y dentro del capó. Apriete firmemente.

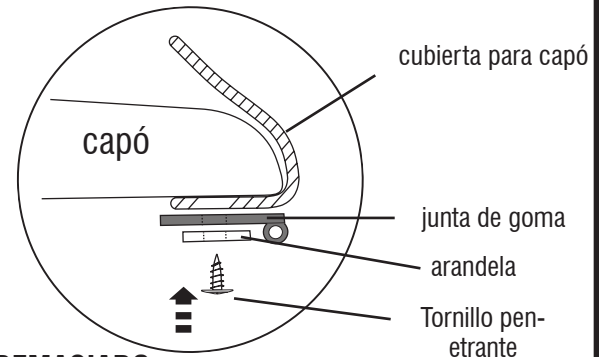
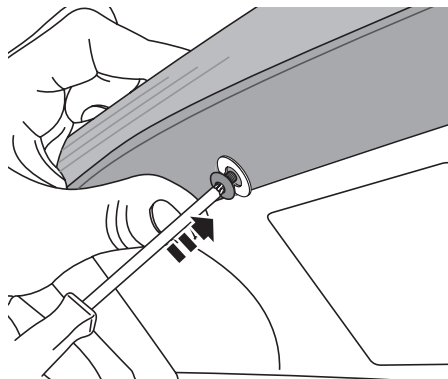

NO AJUSTE DEMASIADO

Aplique presión firme a las pestañas EXTERIORES para asegurar la adhesión de la cinta a la superficie de la campana.

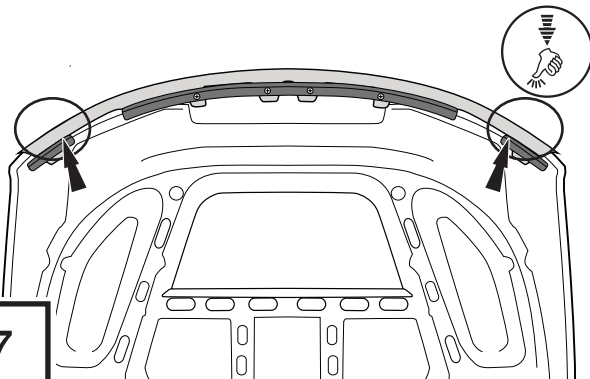

A su vez tanto de la campana paragolpes hacia la izquierda 1 1 / 2 vueltas.

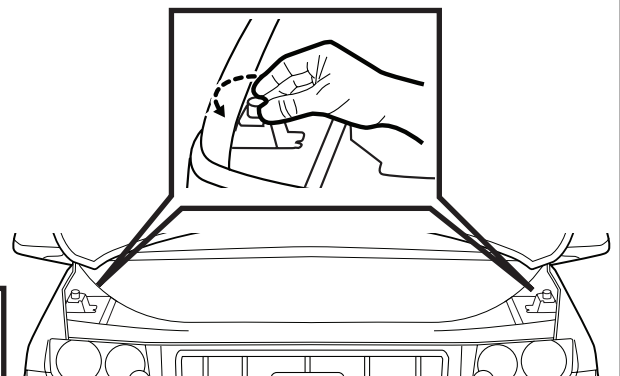

Pasos de instalación

NOTA: El uso real puede variar levemente de ilustraciones.

Cierre el capó.

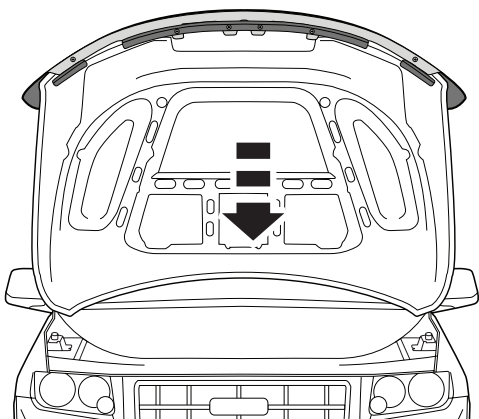

Coloque (4) los soportes en la superficie del capó.

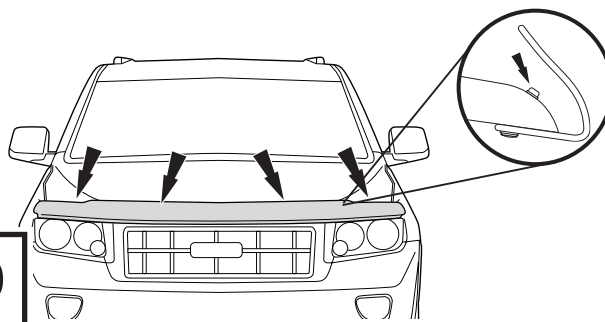

Cuidado y limpieza

- Limpie solamente con agua jabonosa tibia y seque con un paño limpio.



El material del que está hecho el producto puede reciclarse. Considere también reciclar el embalaje en el que viene el producto.



Felicidades

Usted ha comprado uno de los tantos artículos de calidad de Auto Ventshade™ ofrecidos por Lund International. Nuestros productos son nuestro mayor orgullo. Deseamos que disfrute de años de satisfacción con su inversión. Hemos realizado todos los esfuerzos para asegurarnos de que su producto sea de la mejor calidad en cuanto a ajuste, durabilidad, acabado y facilidad de instalación.



Lund International

800-241-7219 • Visite nuestro sitio Web: lundinternational.com

© 2020 Lund, Inc. Todos los derechos reservados.

Auto Ventshade™, el logo de Auto Ventshade™ y el logo de AVS™ son marcas comerciales de Lund, Inc.

