

INSTALLATION INSTRUCTIONS

OUTLAW NERF STEP BARS



APPLICATION:

2015-2019 Ford F-150 SuperCab; 2017-2019 Ford F-250/350

SuperCab

PART NUMBER:

58-53935

CONTENT			
ITEM	QUANTITY	DESCRIPTION	TOOLS NEEDED
1	1	DRIVER SIDE STEP BAR	13MM SOCKET
2	1	PASSENGER SIDE STEP BAR	13MM WRENCH
3	2	MOUNTING BRACKET A	16MM SOCKET
4	2	MOUNTING BRACKET B	16MM WRENCH
5	4	MOUNTING BRACKET C	RATCHET
6	16	M8 SPLIT LOCK WASHER	TORQUE WRENCH
7	16	M8 FLAT WASHER	
8	16	M8 HEX NUT	
9	4	M8 SQUARE NECK BOLT	
10	8	M10 HEX HEAD CAP SCREW	
11	8	M10 BELLVILLE WASHER	
12	8	M10 SERRATED FLANGE NUT	
13	12	M8 PLASTIC RETAINER SQUARES	

ANTI-SEIZE LUBRICANT MUST BE USED ON ALL STAINLESS STEEL FASTENERS TO PREVENT THREAD DAMAGE AND GALLING

Passenger Side Opposite

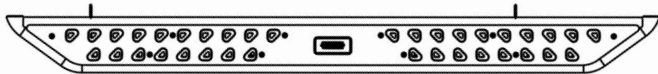

ITEM 1

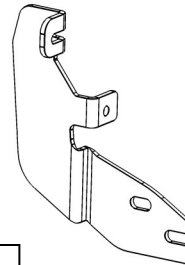

ITEM 3

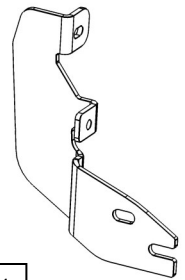

ITEM 4

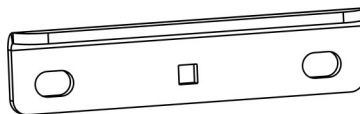

ITEM 5



Westin Automotive Products, Inc.
320 W. Covina Blvd
San Dimas, Ca. 91773

Thank you for choosing Westin products
for additional installation assistance please call
Customer Service (800) 793-7846

www.westinautomotive.com

DATE: 03/26/19

PROCEDURE

1. Remove contents from box, verify if all parts listed are present and free from damage.
Carefully read and understand all instructions before attempting installation.
Failure to identify damage before installation could lead to a rejection of any claim.

2. Start installation on driver's side. On the rocker panel find locations of factory studs. In each location there should be 3 studs. **See Figure 1.**
3. Insert (1) M8 Plastic Retainer (Item 13) on each factory stud. **See Figure 2.**

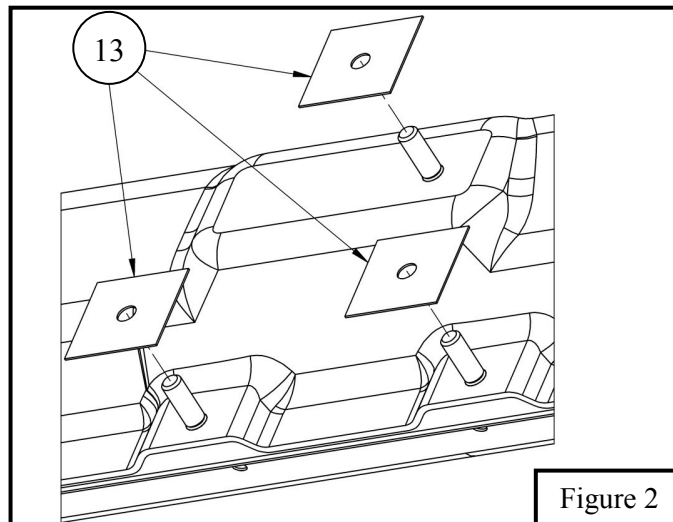
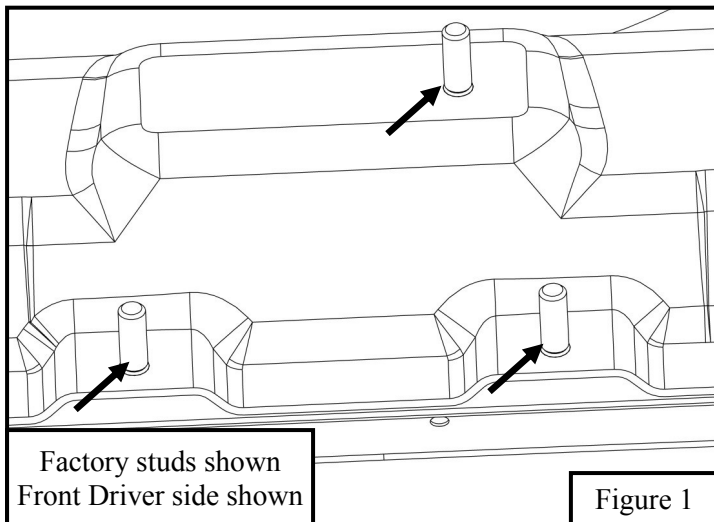

4. Insert the M8 round head square neck bolt (Item 9) through the Mounting Bracket C (Item 5) square hole. Then insert the M8 round head square neck bolt through mounting brackets (Item 3-5) bottom circular hole. Loosely secure with (1) M8 hex nut, (1) M8 split lock washer, and (1) M8 flat washer. **See Figure 3.**
5. Align sub-assembly with the 3 factory studs. Lower 2 factory studs will align with Mounting Bracket C and top factory stud will align with mounting brackets. Loosely secure sub-assembly with (3) M8 hex nut, (3) M8 split lock washer, and (3) M8 flat washer. **See Figure 4.** (Note: See page 3 for bracket orientation)
6. Repeat **Step 3-4** for every mounting location.

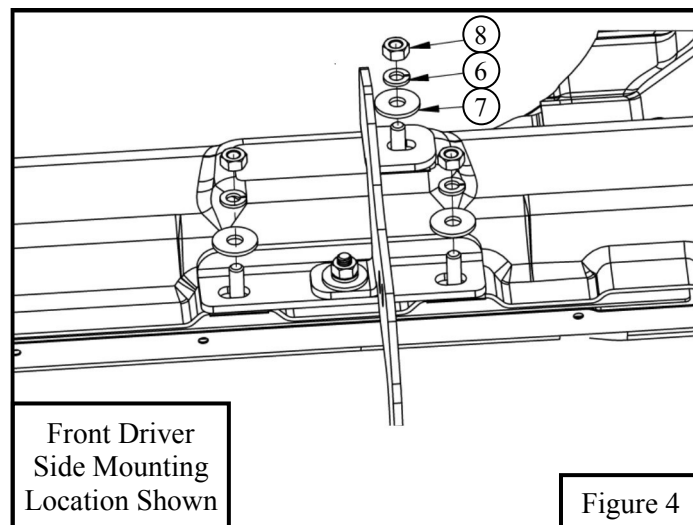
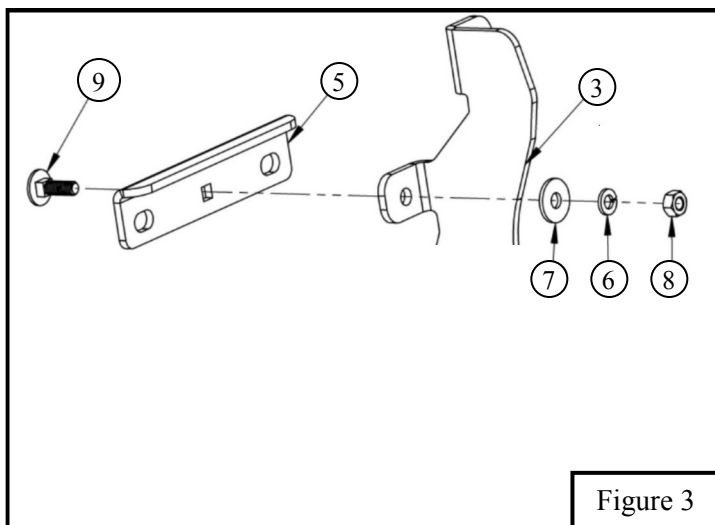

WESTIN

Westin Automotive Products, Inc.
320 W. Covina Blvd
San Dimas, Ca. 91773

Thank you for choosing Westin products
for additional installation assistance please call
Customer Service (800) 793-7846

www.westinautomotive.com

7. For step bar installation, use the supplied M10 Hardware to loosely secure the step bar to the preinstalled brackets. See **Figures 5 & 6**. *Note: Mounting Bracket A is shown; bar installs to other brackets similarly.*
8. Align and adjust the step bars and brackets as needed, then fully tighten all hardware: M8 to 18 ft-lbs, M10 to 38 ft-lbs.

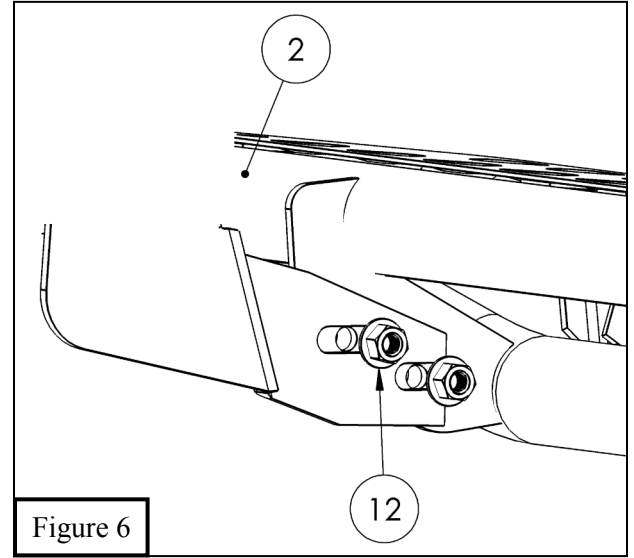
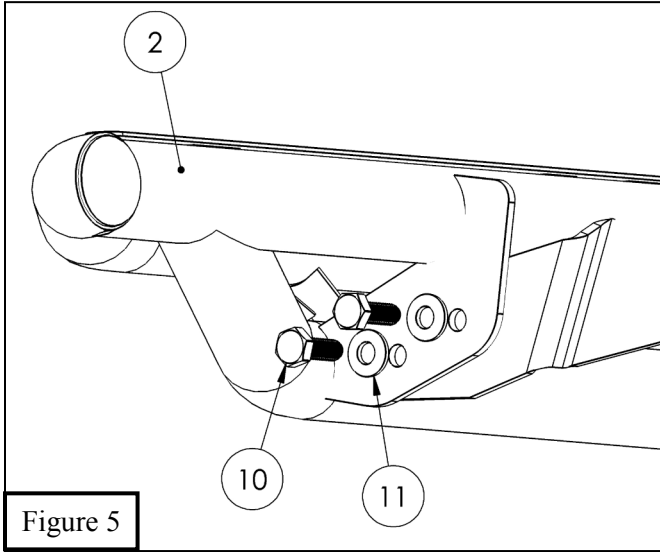

ROCKER PANEL BRACKET LOCATIONS

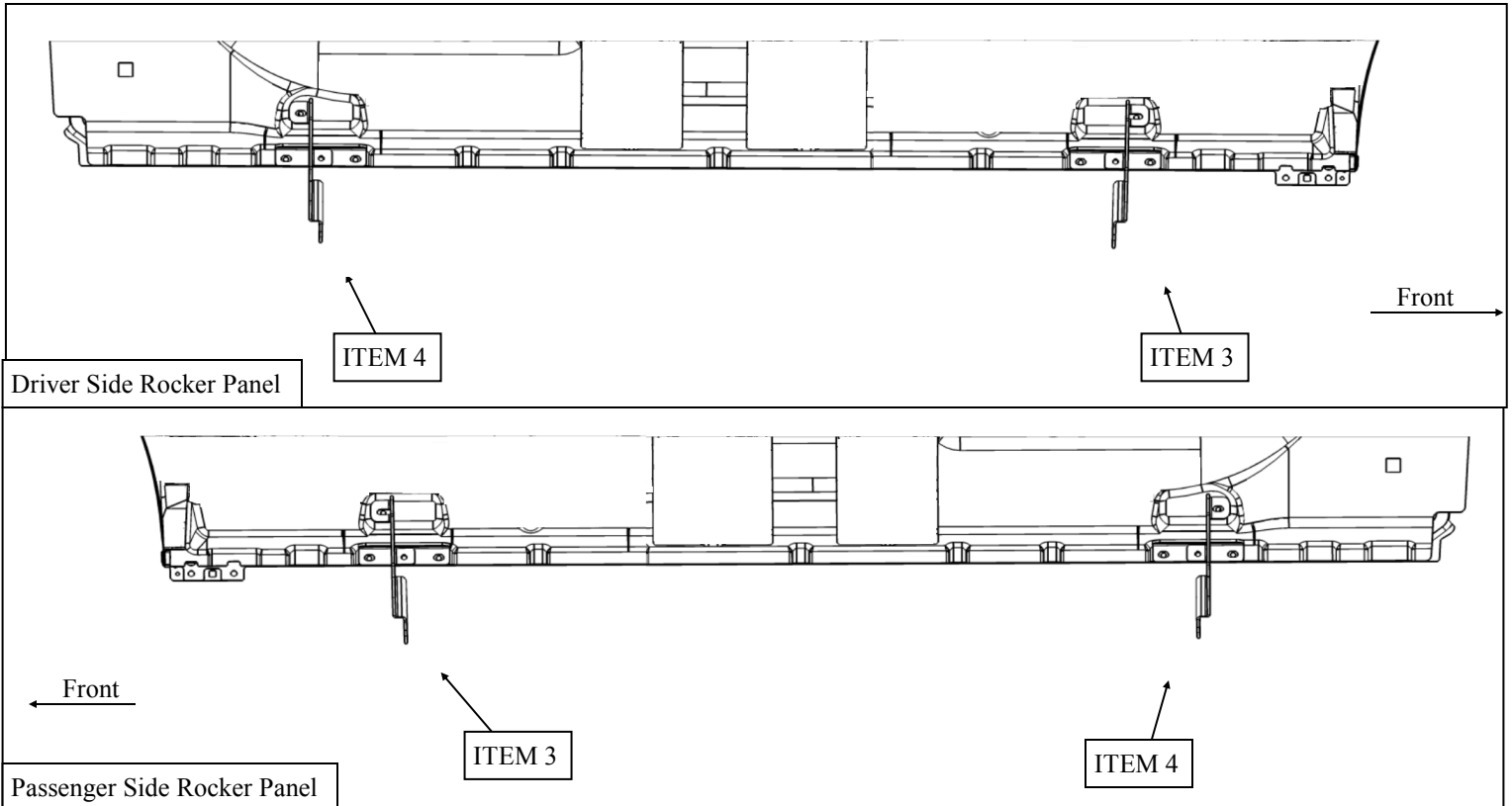

INSTALLATION COMPLETE



CARE INSTRUCTIONS

- REGULAR WAXING IS RECOMMENDED. DO NOT USE ANY TYPE OF POLISH OR WAX THAT MAY CONTAIN ABRASIVES.
- STAINLESS STEEL PRODUCTS CAN BE CLEANED WITH MILD SOAP AND WATER. STAINLESS STEEL POLISH SHOULD BE USED TO POLISH SMALL SCRATCHES.
- GLOSS BLACK FINISHES SHOULD BE CLEANED WITH MILD SOAP AND WATER

WESTIN

Westin Automotive Products, Inc.
320 W. Covina Blvd
San Dimas, Ca. 91773

Thank you for choosing Westin products
for additional installation assistance please call
Customer Service (800) 793-7846

www.westinautomotive.com



WARNING



Failure to follow these instructions could lead to death, personal injury, and / or property damage.

Failure to follow these instructions could lead to death, personal injury, and / or property damage.

FASTENERS:

All Westin supplied fasteners must be utilized and installed in accordance with the installation instructions and apply torque to the specifications as defined. **DOUBLE CHECK ALL FASTENERS BEFORE INITIAL USE, AND PERIODICALLY IN THE FUTURE TO ENSURE PROPER FUNCTION AND SAFETY.**

DRILLING:

Most Westin products do not require drilling for installation. If drilling is defined as required, use caution when drilling a vehicle. **FAILURE TO REVIEW AN AREA TO BE DRILLED MAY RESULT IN PERSONAL INJURY AND/OR INJURY TO OTHERS AS WELL AS VEHICLE DAMAGE.**

EYE PROTECTION:

ALWAYS WEAR SAFETY GLASSES OR GOGGLES DURING THE INSTALLATION PROCESS TO AVOID PERSONAL INJURY.

MAXIMUM TOWING/CARRYING CAPACITY: (if applicable)

The Westin Receiver Hitches will have a visible tow rating label affixed directly on the product. User should never exceed the vehicle manufacturers maximum tow and weight rating regardless of the capacity of the hitch. **FAILURE TO FOLLOW THESE GUIDELINES WILL VOID THE WESTIN WARRANTY AND MAY RESULT IN PERSONAL INJURY AND/OR INJURY TO OTHERS AS WELL AS VEHICLE DAMAGE.**

FOR CALIFORNIA RESIDENTS ONLY-PROP 65 WARNING:

Some products may contain chemicals such as DEHP, which can cause cancer, birth defects or other reproductive harm. For more info go to www.p65warnings.ca.gov



Westin Automotive Products, Inc.
320 W. Covina Blvd
San Dimas, Ca. 91773