

General Fitting Guide - For WHITELINE swaybars.

Page 1 of 2

Universal swaybar fitting guide for replacement and full kit swaybars, to be used whenever specific fitting instructions are not supplied or as a supplementary fitting instruction sheet.

Sound motor vehicle mechanical knowledge is expected.

Stage 1. Swaybar fitment.

- For replacement type swaybars, take note of the fitment, alignment and clearances of OEM swaybar, endlink and any other associated components before removing.
- Apply supplied grease to the contact surfaces of new bushings.
- Place the swaybar in position and connect to the chassis. Parts supplied, procedure to follow and configuration type will vary between individual swaybars.
- In some cases, it may be necessary to raise the vehicle and/or remove road wheels and/or suspension, drive-train or exhaust system components. It is critical that vehicle is safely secured on hoist or on chassis stands.

If suspension components need to be removed, it may be beneficial to measure original wheel alignment settings before continuing

- Proper safety procedures must be followed, and care taken. Be extra careful when working with hot components.
- Always use new hardware if supplied.
- Only tighten fittings with the vehicle at ride height.

Stage 2. Swaybar link assembly fitment and adjustment.

- Swaybar endlink assembly, fitment and tensioning is best done with the vehicle at normal ride height to ensure correct alignment, clearance and operation.
- Fit the swaybar link assembly in place. Parts supplied, procedure to follow and configuration type will vary between individual swaybars.
- For replacement type swaybars supplied without links, re-use factory links and hardware.
- For swaybars supplied with new links and hardware, refer to Figures 1 to 4 for bushing type endlink and their correct assembly. Refer page 2 for Ball-style.
- Whiteline Blade adjustable swaybars vary between 2, 3 and 4 holes per side, depending on application. Refer to Fig. 5 to work out the desired setting on how to connect the endlink. If multi-hole endlink brackets are supplied, choose the hole that maintains the endlink close to vertical.

Caution: WHITELINE recommends starting with softer setting rather than harder.

- Always use new hardware if supplied.
- Tighten all fittings with the vehicle at ride height.

Caution: Do not over tighten swaybar pin type link bushes, refer Fig 1. Nuts should be tightened until washer meets the bush & stops rotating. Then tighten a further $\frac{2}{3}$ of a turn. Over tightening compresses and pre-loads the polyurethane bush which reduces articulation and may cause premature failure.

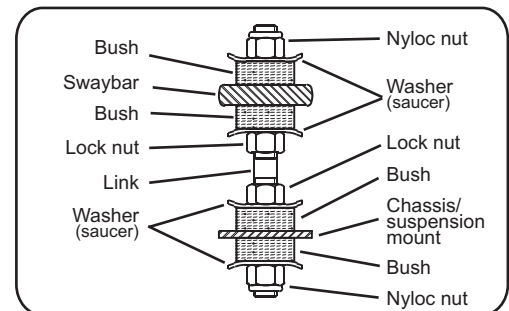

Fig.1. Whiteline double pin type link.

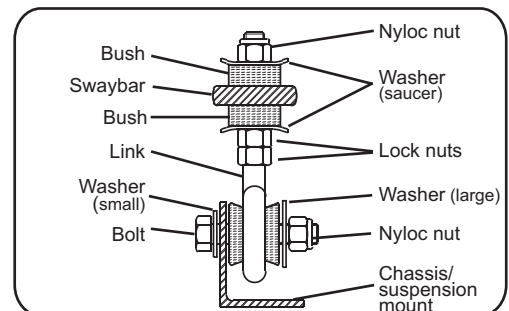

Fig.2. Whiteline pin/eye type link.

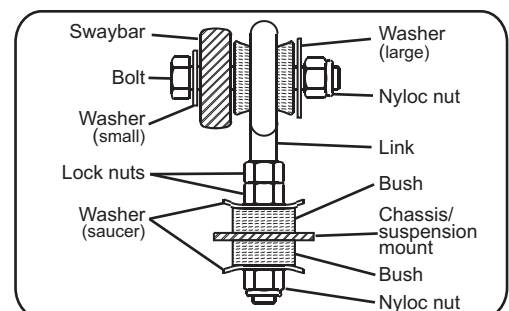

Fig.3 Whiteline eye/pin type link.

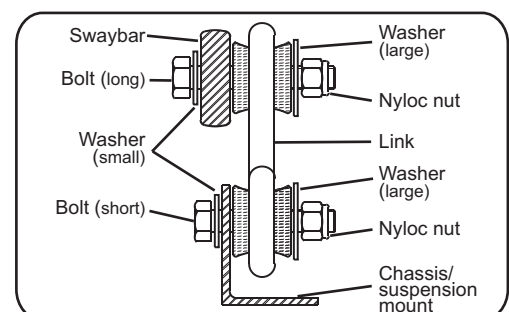

Fig.4 Whiteline double eye type link.

Warning: Please drive carefully while you accustom yourself to the changed vehicle behaviour.

General Fitting Guide - For WHITELINE swaybars.

Continued - Page 2 of 2

Universal swaybar fitting guide for replacement and full kit swaybars, to be used whenever specific fitting instructions are not supplied or as a supplementary fitting instruction sheet.

Stage 3. Post installation check and maintenance.

- Depending on the application and the removal of suspension components during installation in stages 1 and 2, wheel alignment settings may have been altered. Check wheel alignment settings, and adjust as required.
- Re-tension all fittings after a settling-in period, but not later than 100kms (60miles) after installation.
- For noise and friction free operation, carry out periodic inspections and maintain proper bushing lubrication.

WHITELINE swaybar lateral locks may be supplied (or purchased) - refer supplementary install guide Z5160 also supplied in kit. Refer image below -

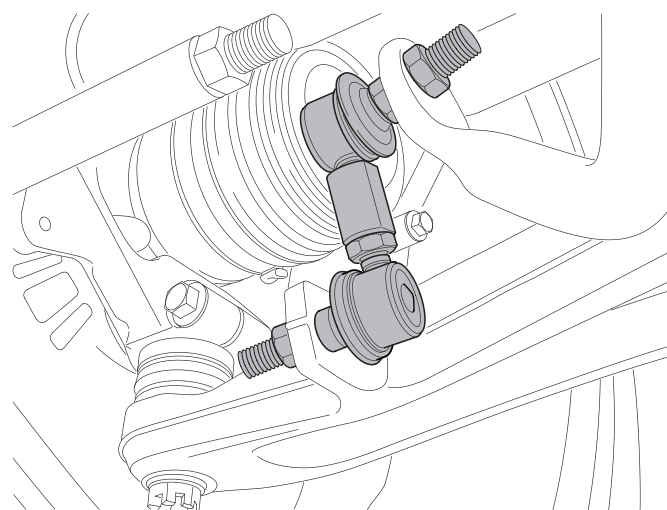
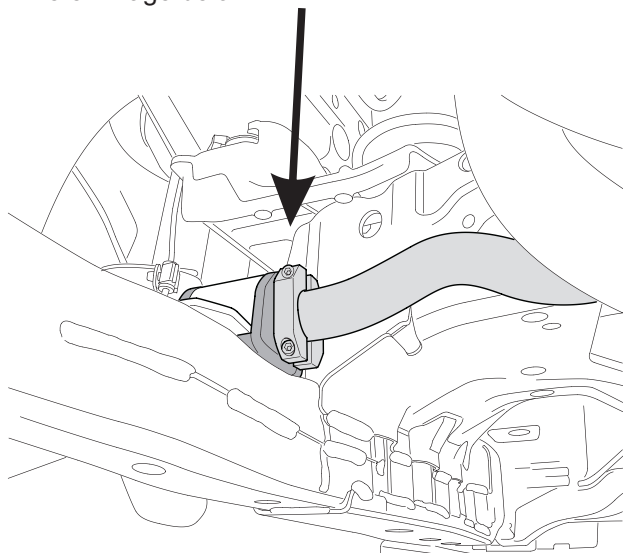

WHITELINE Ball-style links - refer supplementary install guide Z5146 also supplied in kit.

Fig.5 WHITELINE 3 hole Blade swaybar



WHITELINE Blade adjustable swaybar - rate adjustment guide

Warning: Please drive carefully while you accustom yourself to the changed vehicle behaviour.

Installation Guide

Performance Swaybar Links - Live Adjustable

(This installation guide should be used in conjunction with the workshop manual)

WHITELINE HEAVY DUTY swaybar links improve swaybar function and reaction time - due to forged steel, low-compliance ball joints along with live-adjustable turn buckles made from 6061 heat treated aluminium.

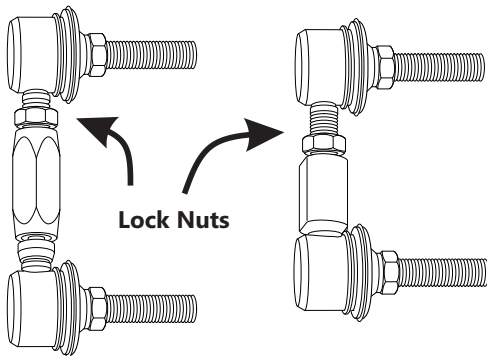

- Raise vehicle evenly and safely support.

Never rely on a Jack only

Note - Swaybar links are best accessed with wheels at full droop.

- Lubricate all threads before un-bolting old links

Take note of original link position and stud direction before removing. Or replace one link at a time.

- Remove old link and place next to new WHITELINE link.
- Loosely adjust WHITELINE link to similar length to old link length - do not tighten lock nuts yet.

Note - if vehicle is very low (or high) - a different length link may be entertained — *Refer Page 2*

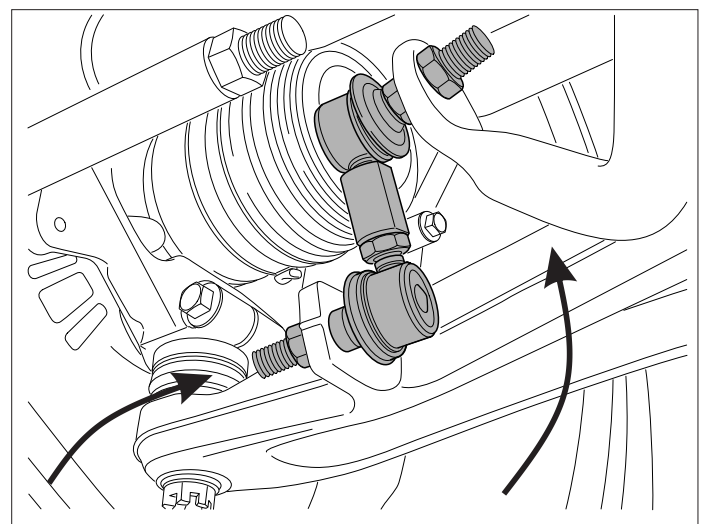

Subaru Example - note swaybar location and link stud direction

Installation Guide

Performance Swaybar Links - Live Adjustable

(This installation guide should be used in conjunction with the workshop manual)

IMPORTANT - Big diameter/performance swaybars add significant stress to swaybar links. WHITELINE recommends a minimum thread engagement of 13-14mm - refer image below. WHITELINE supply 'hardened/thick washers' to maintain solid contact to swaybar blade, ensuring excellent operation.

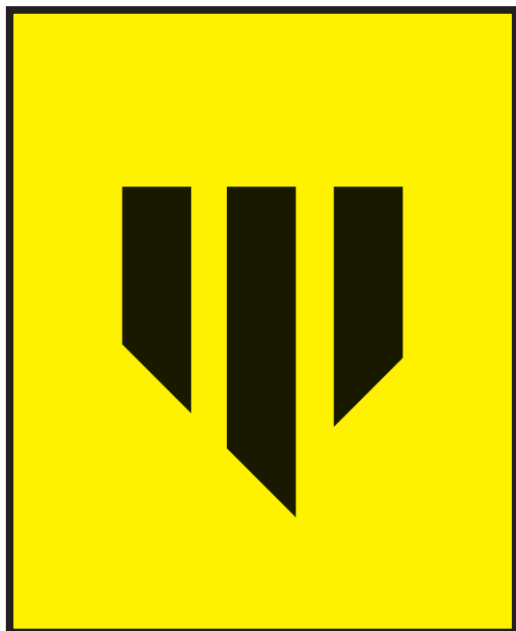

Toyota Example below - swaybar performance is best with swaybar near 90 degrees to swaybar link

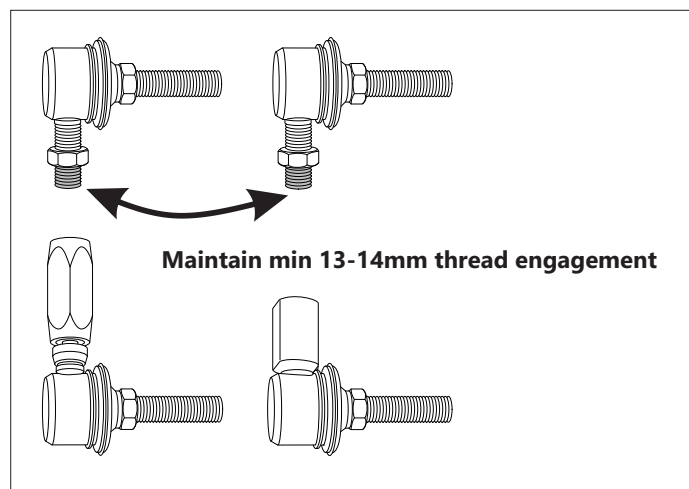

Subaru Example below - place hardened washers either side of swaybar blade

- Place 1x hardened washer over each stud before pushing through swaybar hole.
- Proceed to bolt up new links to vehicle.

IMPORTANT - confirm supplied hardened washers are placed either side of swaybar blade (and vehicle control arm)

- Tighten ball joints with supplied flange nuts, then proceed to fine tune turn buckles.

WIND centre turn buckles - lengthen or shorten link length until there is **zero** pre-load on swaybar. Now tighten lock nuts.

If possible, this is best done at ride height.
(wheels on ramps)

- All nuts to be re-torqued after 100-200kms



GREASE FREE TECHNOLOGY



Introducing Grease Free Technology Bushings

Bushings supplied in this kit feature not only the latest synthetic elastomer bushing material technology but a high performing PTFE inner lining boasting an extraordinary low coefficient of friction. This inner lining eliminates the need to lubricate the bushing on installation and therefore makes these bushing 'grease free'!

Superior friction management

- reduces heat build up known to deform or degrade bushing over time
- dramatically reduces high frequency noises (squeaking)
- eliminates the need for maintenance/ greasing

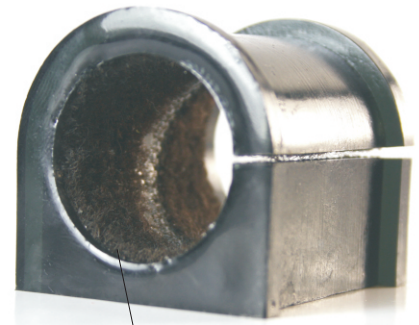

PTFE LINING

Installation tip

Ensure a clean mating surface when installing these bushings for optimum performance!

Frequently Asked Questions

What happens if I do apply grease to the lining?

Don't stress, simply wipe away as much of the lubricant from the surface as possible and install. Adding grease does not further improve the bushings function/ performance nor does traces of lubricant impede the function/ performance.

Do I need to grease other areas of the bushing?

Simply, no! Unless the kit is supplied with a grease packet and lubrication instructions, no other area of the bushing requires lubrication.

Do these bushings require maintenance?

Significant improvements in grease retention within bushing design has dramatically improved over recent years, however this new grease free technology does away with all lubricants and subsequent or periodical maintenance.

Is this technology available across the entire range?

For the most up to date offering of grease free technology bushings visit the website!

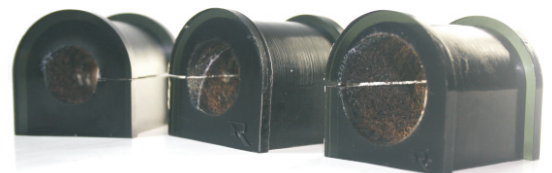
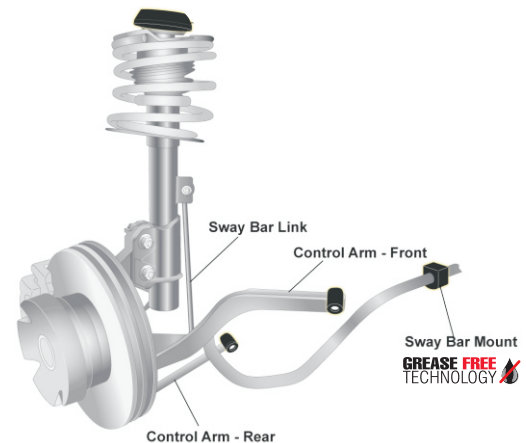

FRICION FREE | SILENT OPERATION | MAINTENANCE FREE