



*Stylish & Economical Roll-Up Cover*



## INSTALLATION INSTRUCTIONS AND OWNER'S MANUAL

Thank you for purchasing an ACCESS® TONNOSPORT™ Cover. ACI has manufactured this roll-up cover with pride using superior quality materials and craftsmanship. With proper care, your cover will provide years of service and enjoyment.

**NOTICE TO INSTALLER:** It is recommended you take the time to read these instructions before installing this cover even if already familiar with the product. Often improvements are made without prior notice. Always handle cover and components with care to avoid damage. If you find a part missing or defective, or if you are having trouble installing this product, please have serial number ready (found on decal under rear bar by tailgate) and call the customer service number on the back page. **When done, these instructions and warranty information** must be given to the consumer.

**NOTICE TO CONSUMER:** Before using this product, read the operating instructions, maintenance and safety sections of this owners manual and save for future reference.

### FOR YOUR RECORDS:

DATE PURCHASED \_\_\_\_\_

WHERE PURCHASED \_\_\_\_\_

SERIAL NUMBER \_\_\_\_\_

(Located on decal under rear bar by tailgate)

### WARRANTY REGISTRATION

Promptly confirm your warranty by registering on-line at [www.tonnosport.com](http://www.tonnosport.com)

# HELP LINE

**Problems? Questions? Missing or Damaged Parts? Installation Questions?**

**Visit Us Online First! [www.agricover.com/index.php/faq](http://www.agricover.com/index.php/faq)**

**PARTS KEY**

**Driver Side**

rear

**A**



**Passenger Side**

rear

**B**

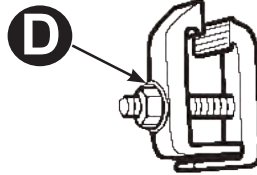
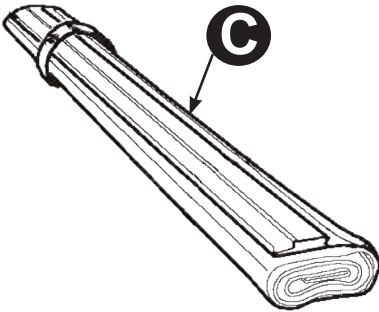
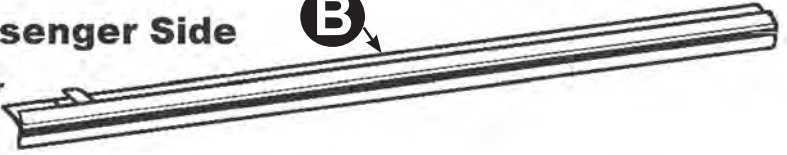

6X

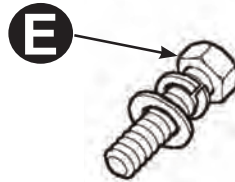

2X

**TOOLS NEEDED**



**1/2"**



**9/16"**



**(2X)**

# INSTALLATION INSTRUCTIONS:

(NOTE: For additional installation assistance visit us at [tonnosport.com](http://tonnosport.com))

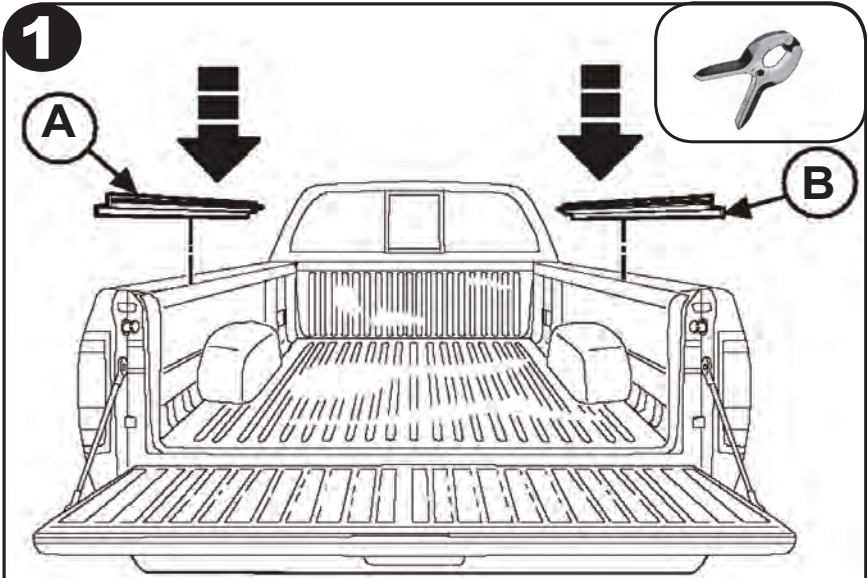

**Driver Side** - end of rail with slotted hole goes to front behind cab, trigger latch to rear.

**Passenger Side** - end of rail with slotted hole goes to front behind cab.

**Weather seal**---side of rails go against inside edge of pickup box.

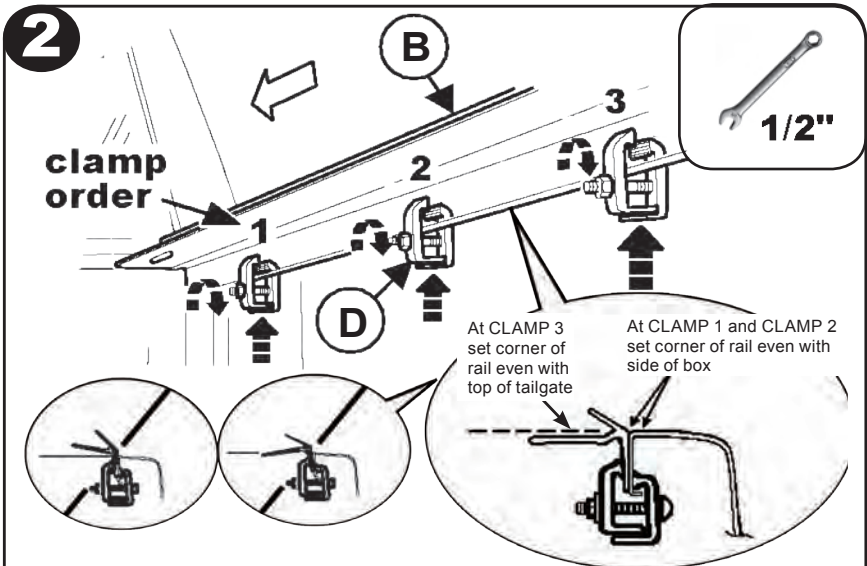

Position front and rear clamp about 8 inches from ends and one clamp in middle. Follow clamp order sequence in diagram. Clamps can be moved up or down for rail leveling adjustment.

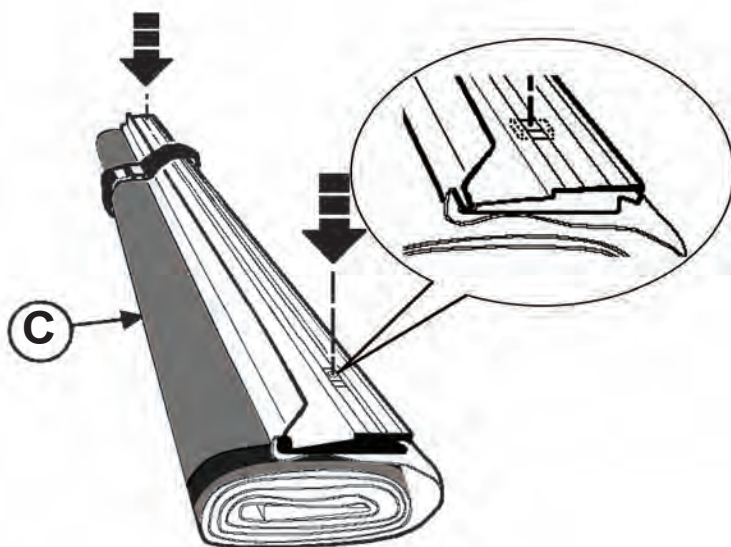
**3**

Cover is shipped in preassembled rolled open position. The visible bar (with nuts in channel) goes to front behind cab.

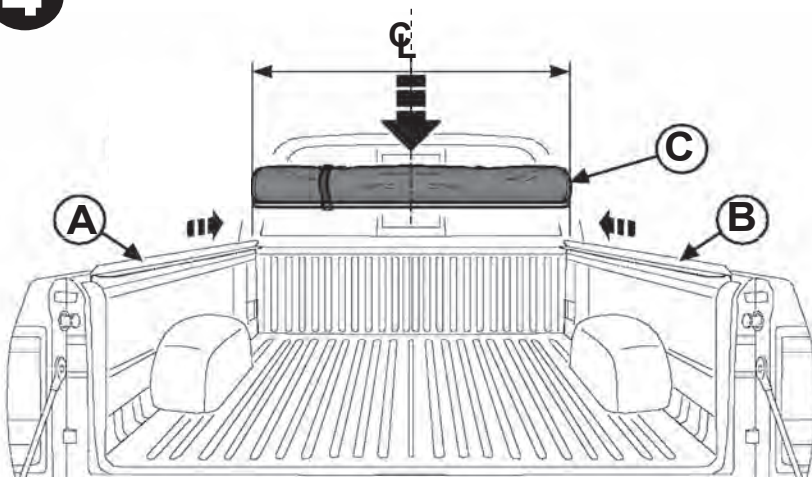
**4**

Place cover roll on top of rails at front behind cab-- with bar setting on rails-- centered between them. (Storage strap to driver side)

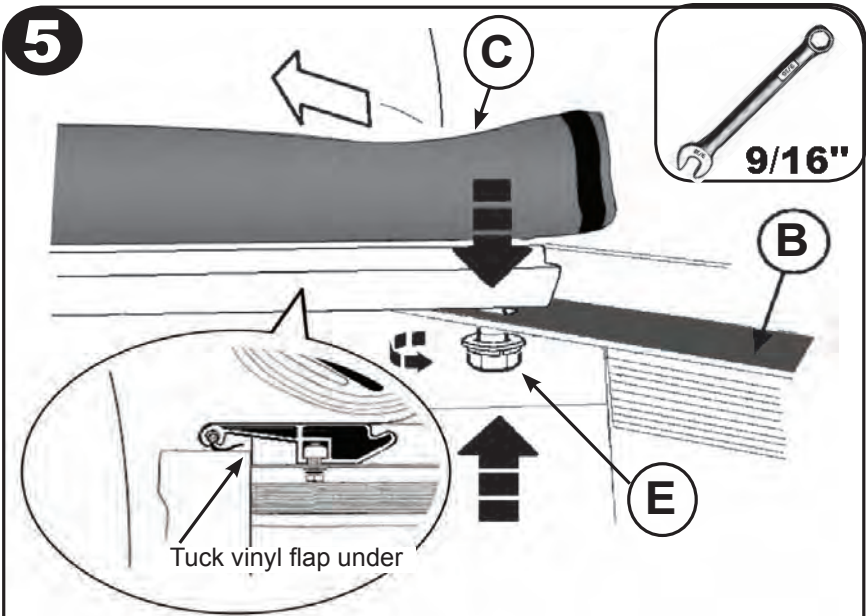

At each end, align nut in front bar with slotted hole on rail. Insert a bolt, flat and lock washer up through slotted hole and turn into nut. Center bar between rails. Then adjust bar until bolt is centered in slotted hole and tighten. Do same with bolt at other end.

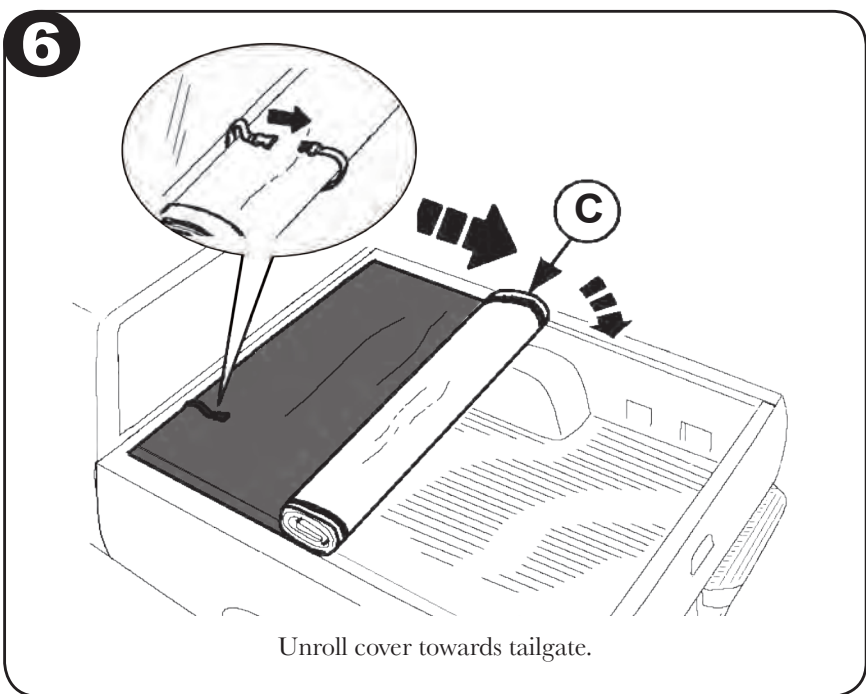

7

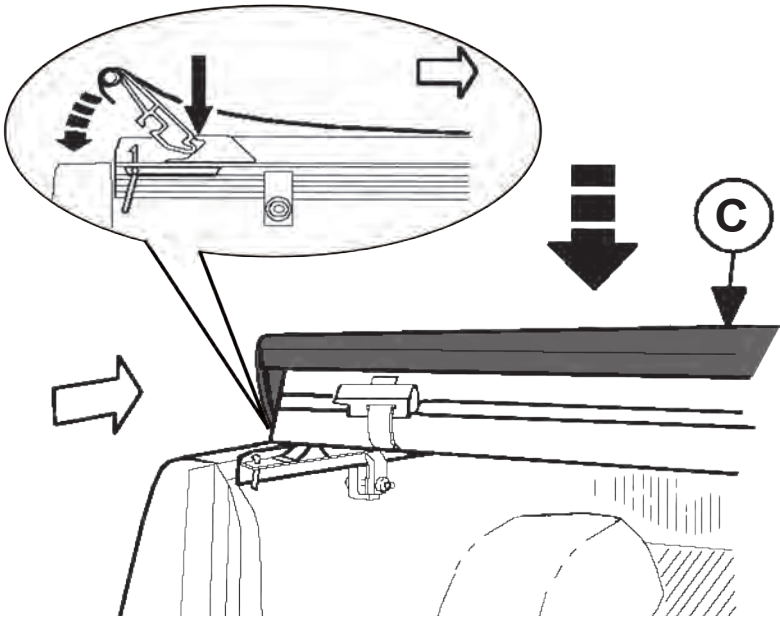

Engage rear bar into strike on rail and push down to latch.

8

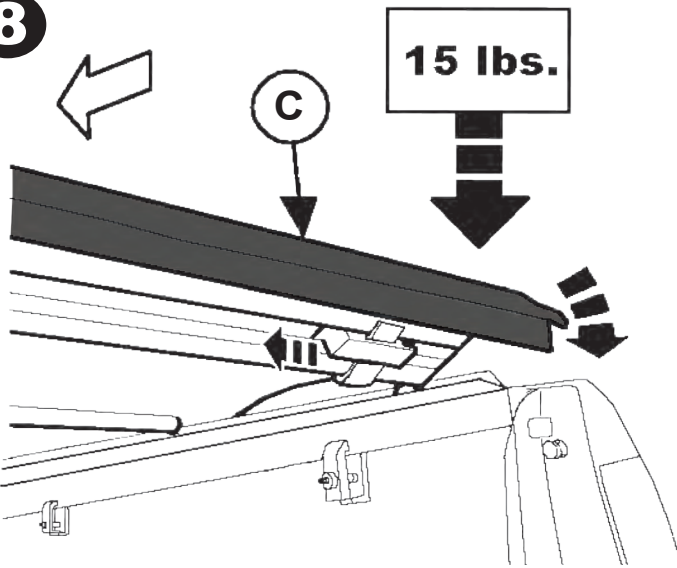

Check tailgate closing. Adjust rear of rails up for more tailgate clearance, or down for less clearance. Check cover tension with tailgate down. Closing bar down and latching should take about 15 lbs. of pressure.

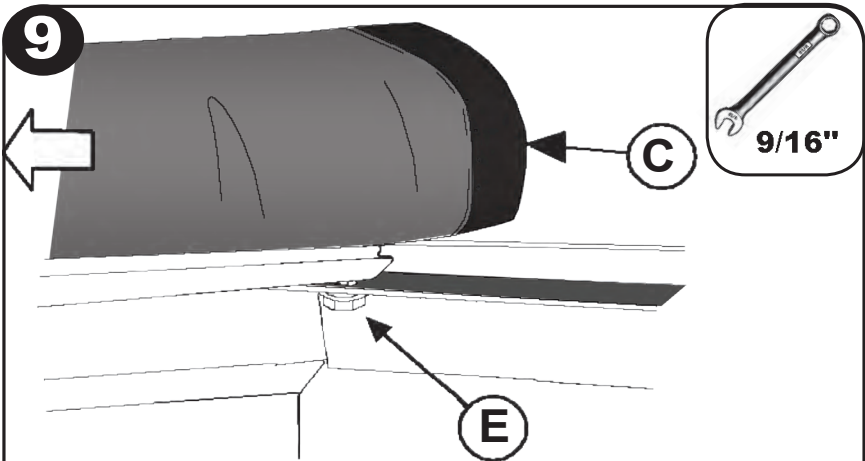

- To **adjust** tension, roll cover open, loosen each bolt under front bar.
- To **increase** tension push each end of bar toward CAB about 1/16-1/8 inch at a time. Tighten bolts and close cover to check tension. Repeat if needed.
- To **decrease** tension, push each end of bar away from CAB about 1/16-1/8 inch at a time. Tighten bolts and close cover to check tension. Repeat if needed.
- On occasion, it may be necessary to set one end of front bar slightly forward of opposite end. Doing this will swing rear of cover to one side or other. This adjusts cover for better fit at tailgate.

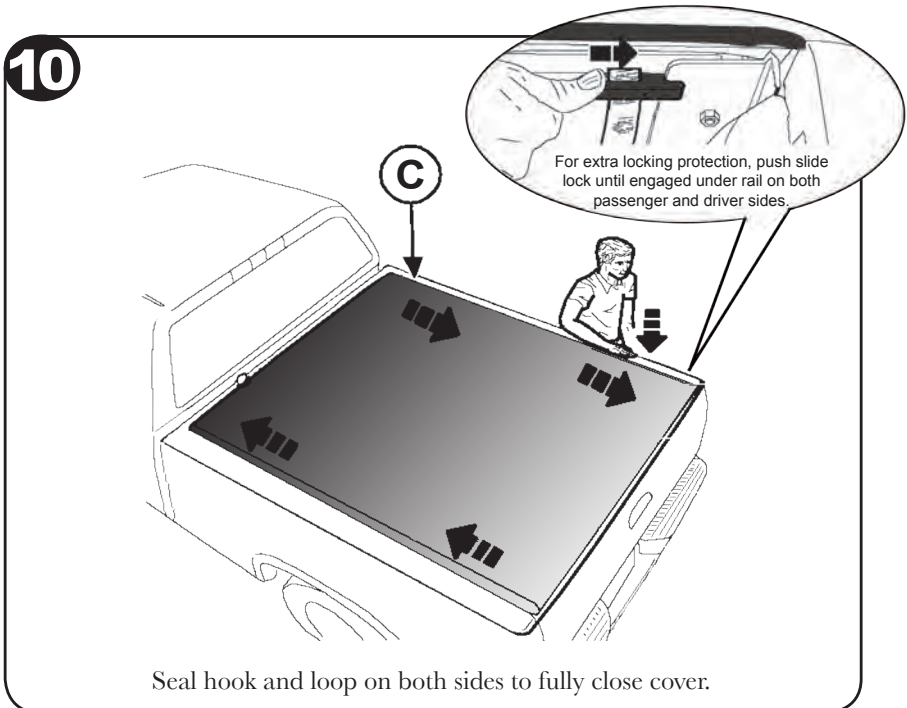

## OPENING/CLOSING THE COVER

### OPENING FROM CLOSED POSITION



### CLOSING FROM OPEN POSITION

- Release the storage strap and roll cover toward tailgate
- Position the roll-up bar against the strikes. Push down on bar until secure  
Optional - push slide lock(s) into place
- Seal hook and loop on sides of the cover

## SAFETY INFORMATION

- Do not cover cargo that is higher than the cover.
- Do not place object(s) on or against the cover or its framework at any time
- Always secure cargo so it cannot shift and damage the cover or its parts.
- Do not use the covers framework to tie down cargo.
- Never stand, sit or ride on the cover or allow others to do so.
- Do not leave valuables in an unattended vehicle as cover does not prevent theft of contents in truck box.
- The cover does not eliminate moisture and dust from entering the truck box. Special wrappings or packaging of the contents may be necessary.
- Due to poor ventilation, if you allow a pet/animal in the box, leave cover open. Do not allow people or animals to occupy box with the cover closed.
- When towing vehicle backwards, cover must be rolled fully open and secured with safety straps or fully closed and secured with manual slide lock.
- ALWAYS finish securing the cover. Use caution when operating cover in windy conditions.
- Periodically check and/or retighten clamp bolts as needed.
- Periodically check and/or retighten front bar tensioning bolts as needed.

## TROUBLESHOOTING

PROBLEM	SOLUTION
Cover too loose	Loosen bolts under front bar and move bar forward. Retighten bolts
Cover too tight	Loosen bolts under front bar and move bar rearward. Retighten bolts
Gap between roll-up bar and tailgate	Rails set too high (Refer to #2)
Cover is too wide ...too narrow	Check rails. Rails in - too wide - push all clamps to top of rail Rails out - too narrow - pull all clamps down on rail (Refer to #2)
Lopsided cover too much on one side	Check front bar. It must be centered side to side (Refer to #4)
Top of tailgate hits rear bar when attempting to close	Raise side rails at rear of box until tailgate closes without pushing rear bar up (Refer to #2)
Manual slide locks too loose or too tight	Use 1/8" allen wrench and adjust set screw tighter or looser as desired. Lock performs best with some friction (Refer to #10)

## INSPECTION, MAINTENANCE & TIPS (FOR A LONGER LASTING COVER)

- Inspection and much of the maintenance can be done by the operator. It may be necessary to review the installation and operating instructions.
- Periodically inspect the cover assembly. Check for loose bolts and parts and then tighten if needed. Test the operation to ensure that the parts are functioning properly and that the cover is in top operational condition.
- If latch has been damaged replace with new one. NOTE: Inspection and/or maintenance should also be performed anytime a malfunction is observed or suspected. If you need assistance inspecting and/or servicing your cover, or if you want to order a replacement part, call the customer service number listed in the warranty. Always use original equipment replacement parts for your cover.
- Vinyl cover can be treated with water based vinyl protectants. Avoid silicon based products.
- When cleaning, for best results use mild liquid soap and water. Never clean with petroleum or citrus based products.
- Always keep cover closed when not in use.
- Keep hook and loop sealed when cover is closed.
- Keep the cover tight, cover vinyl should sound drum-like when tapped on.
- Engage manually operated slide locks while traveling and before entering drive-through car washes.
- Avoid storing cover in its rolled-up position for long periods of time.
- Avoid allowing cargo to rub against cover while transporting, whether in open or closed position.

**NOTE ON BED LINERS:** With an under-the-rail drop in bed liner, installation is possible with minimal trim cutting of bed liner at front corner of box and back by tailgate to allow side rail to install properly. Considerable trim cutting is required with an over-the-rail drop in bed liner.



# MANUFACTURER'S PREMIUM COVER™ LIMITED WARRANTY

Agri-Cover, Inc. extends the following limited warranty to the original retail purchaser of any ACCESS® TONNOSPORT Roll-Up Cover:

Agri-Cover, Inc. warrants to the original purchaser, for a period of three (3) years from the date of purchase of the cover, that its ACCESS® TONNOSPORT cover is free from defects in material and workmanship, under normal use, as long as the original purchaser owns the truck on which the cover was originally installed and as long as the cover remains properly installed on said truck.

Agri-Cover, Inc.'s sole obligation under this limited warranty is limited to the repair or replacement, at its option, of defective parts only. No labor or service allowance is given or implied. **INNO EVENT SHALL AGRI-COVER, INC. BE LIABLE FOR INCIDENTAL, CONSEQUENTIAL, OR SPECIAL DAMAGES. AGRI-COVER, INC. EXPRESSLY DISCLAIMS ANY AND ALL IMPLIED WARRANTIES OF MERCHANTABILITY, AND THERE ARE NO WARRANTIES WHICH EXTEND BEYOND THE LIMITED WARRANTY DESCRIPTION CONTAINED HEREIN.**

For warranty performance, call our Customer Service Department at 701-251-1427 to determine if only a replacement part is needed or if the cover needs to be returned for inspection and repair. **Warranty registration must be on file and/or proof of original purchase (detailed and dated receipt) required for warranty to be effective. Goods to be returned must have a pre-authorized RA # (Returned Authorization Number) - obtained by calling the number above.** Mark the number on the package and ship it freight prepaid to address below. Agri-Cover, Inc. will pay freight to return goods to sender.

This limited warranty does not cover any damage due to accident, abuse, misuse, alteration, neglect, improper installation, or ordinary wear and tear.

This limited warranty gives you specific legal rights and you may have other rights, which vary, from state to state.



Agri-Cover, Inc.  
Customer Service Dept  
3000 Hwy 281 SE  
PO Box 508  
Jamestown, ND 58402  
Phone: 701-251-1427

## **ACCESS - A Division of Agri-Cover, Inc.**

ACCESS is a registered United States trademark of AGRI-COVER, INC.  
U.S. Patent Nos. 6,543,835; 6,672,644; 6,851,738; 7,048,227;  
7,008,000; 7,104,586; 7,066,524 ;7,472,941; 7,621,582; and other patents pending.

**PHONE 701-251-1427 7:30 am - 5:30 pm Central Standard Time  
Monday thru Friday except Holidays**

# You May Also Be Interested In Our SnowSport Utility Plows

## 3 DISTINCT MODELS TO CHOOSE FROM



- Simple bolt on install, mounts in minutes
- No electric or hydraulic components to freeze or malfunction
- Won't scratch concrete or pavers, remove gravel or turf
- Easy storage between snowfalls or during off season
- Made model specific for your application
- Fits trucks, suvs, atvs, utvs, zero turn mowers and more

### RUST RESISTANT BLADE



Heavy duty, corrosion-resistant, anodized aluminum blade repels rust, so it never needs painting.

### TURF FRIENDLY



Built in trip edge won't scratch concrete, brick or black top, tear up grass surfaces or remove gravel.

### NO EXTRA LIGHTS



The practical design does not block headlights in plow or transport position.

### EASY TO LIFT



Our plows are easily lifted by one person. Lower the blade, plow until finished, then lift the blade back to transport position.

**Call or go online to get yours today!**

# HOW THE SNOWSPORT PLOWS OPERATE

## LIFT BLADE



To begin plowing, remove pin, lift blade one end at a time and lower it over push frame, then replace the pin.

## DRIVE FORWARD

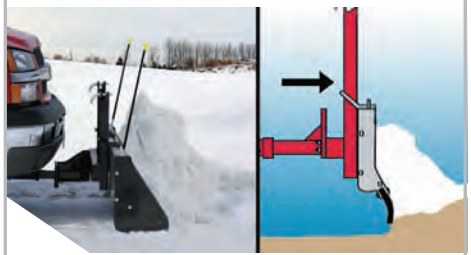

The blade is guided by a push frame that allows it to slide up and down with the grade of the terrain.

## BACK UP

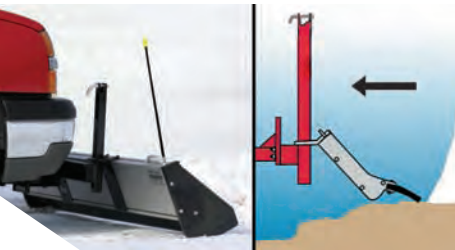

When backing up, the blade lies back, skimming over the ground. When driving forward, blade automatically re-engages for plowing. All you do is drive.

## LIFT BLADE WHEN DONE



When finished plowing simply remove pins and lift one end at a time into holders and secure with pins. It's that easy!

*"I love this plow! First thing I'm asked is does it work? And then, where did you get this? We get some crazy weather here in Michigan, we can get snow every day and sometimes we get snow all at once, this plow handled all of my conditions wonderfully. Once my neighbors saw that this plow did not ruin the grass or move away all of the stones on the driveway, I was asked if I could plow their areas."*

Bob Werbrouck  
Fenton, MI

*"My first use of the Snow Sport 180 came after a 14" snow fall. It worked Great! It took about 20 minutes to get the hang of driving backwards and pushing snow but after that I have recommended to friends and co-workers to check them out. Took an hour to plow what would have taken me 4-5 hours to blow with a 10 hp snow blower. Great product!"*

Barry R Bender  
Dillsburg, PA

*"I bought the 6 ft plow for my 2009 Yamaha Rhino 450 and one word - Awesome!! I am critical of any product but this one is up to snuff. Performs just like described and better."*

Doug Parks  
Cambridge, MD

**877-289-0648**

**[mysnowsport.com](http://mysnowsport.com)**

# Check out our Accessory Products

## The perfect complement to your roll-up cover purchase.

### Access™ EZ-Retriever®



Easily grab items that slid to the front of your truck bed from driving.

Works great for pushing items to the front of the truck bed.

Extends to 5' 9". Easily adjusts to the perfect length for any size bed.

### Access™ TrailSeal® Tailgate Gasket



Seals gaps around the perimeter of the tailgate.

Prevents dust, rain and snow from entering through the tailgate.

The tailgate does not tightly seal without Access™ TrailSeal®.

### Access® Truck Bed Pockets HD



6" tall diamond tread, aircraft grade aluminum.

Allows you to store gear at the rear of the truck bed.

Allows full space between wheel wells.

### Access™ Total Bed Seal



Seals gaps in the box of 07-10 GM/Chevy new body truck beds.

Prevents dust, rain and snow from entering the truck bed.

The kit works with tonneaus, toppers and lids.

### Access® Truck Bed Pockets G2



5" tall, galvanized with a smooth, polished finish.

Creates extra storage from wasted space.

Provides easy accessibility to cargo at the rear of the truck bed.

### Formula 2 Tonneau Cleaner



Water-based spray cleaner that conditions, cleans, and protects.

20 oz. plastic spray bottle.

No oily mess and no destructive silicone.

### Access Cargo Management HD & G2

Access® Truck Bed Pockets and Access™ EZ-Retriever® combined in one Cargo Management Kit.

Prevents items from sliding to the front of the bed.

Available in both Access® Truck Bed Pockets HD and G2.



**Get Yours Today!**

**877-289-0648**

**accesscover.com**