

Care and Cleaning

1. Wash only with mild soap & dry with a clean cloth.
2. Do not use automatic "brush - style" car washes.
3. Do not use cleaning solvents of any kind.
4. Pressure car washes are okay as long as you hold the wand no closer than two feet from the cover.
5. We recommend the same quality products normally used for vinyl tops to keep your cover clean. When using a protectant, be sure that it is water based.
6. Periodically check clamps for shifting due to road vibrations.
7. Do not use any part of this tonneau as a tie down.
- ⚠ 8. Do not drive with the cover partially attached. This may cause damage to your truck and your cover.

Congratulations!

You have purchased one of the many quality Lund® branded products offered by Lund International, Inc.

We take the utmost pride in our products and want you to enjoy years of satisfaction from your investment.

We have made every effort to ensure that your product is top quality in terms of fit, durability, finish and ease of installation.



Lund International, Lund Accessories Division
300 Horizon Drive
Suwanee, GA 30024
800-328-5863 • Fax 800-782-5448 • Visit us at lundinternational.com



© 2004 Lund International, Inc. All rights reserved.
Lund ® and the Lund ® logo are trademarks of Lund International, Inc.



Genesis™ Snap Tonneau Instructions

For proper installation and best possible fit, please read all instructions BEFORE you begin.
For technical assistance or to obtain missing parts, please call Customer Relations at 1-800-328-5863
NOTE: If installing on truck with bedliner, see step 9 before installing.

Contents

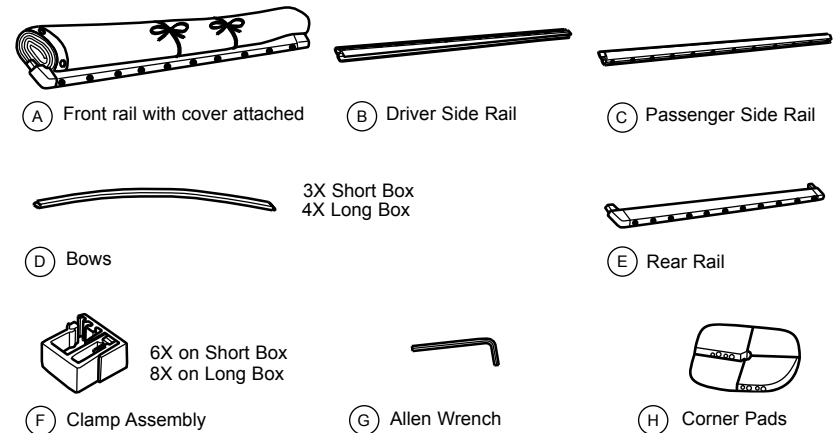

Tools Required

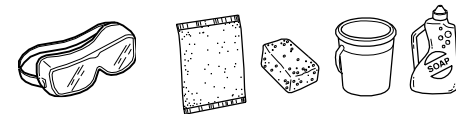

Important Safety Information

⚠ WARNING

- Do not drive with the cover partially attached. This may cause damage to your truck and your cover.
- Do not use any part of this tonneau as a tie down.
- Periodically check clamps for shifting due to road vibrations.
- Pressure car washes are okay as long as you hold the wand no closer than two feet from the cover.
- Do not use cleaning solvents of any kind.
- Do not use automatic "brush - style" car washes.

Preparation Before Installation

- Wash the upper rail surfaces of the truck bed.
- Be sure to completely dry the upper surfaces of your truck bed before installing your rails.

Installation Steps

1703096
Rev.1

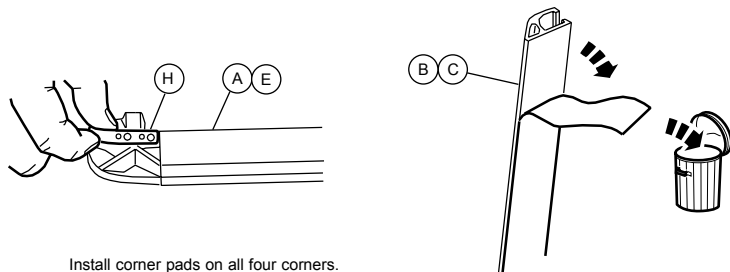

Install corner pads on all four corners.

Remove and discard the protective paper liner from the underside of the tonneau rails.

1

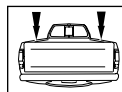
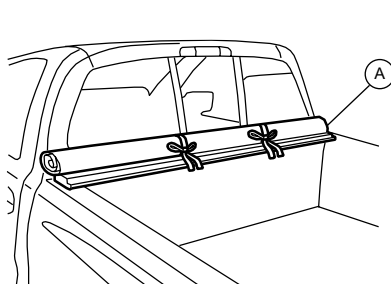

Place the front rail and cover assembly on the top of the truck bed next to the cab.
The cover has tie straps to keep it from being damaged when bulk hauling.

2

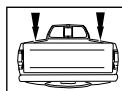
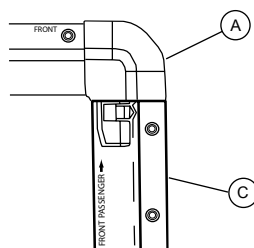

Connect the driver and passenger rails to the front rail. The arrow points to the front of the truck.
Slide the rail over molded leg of the front rail corner. You will hear a click sound when rail is in the correct position.
With tailgate closed, install the rear rail onto the side rails.

3

Installation Steps

1703096
Rev.1

⚠ CAUTION: USE SAFETY GLASSES WHEN CUTTING



For installation with bedliners.

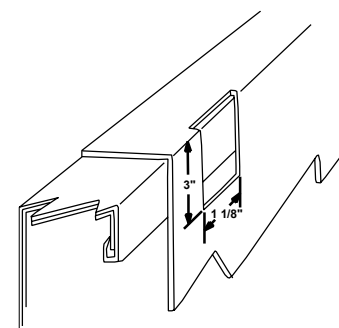

Cut a 1 1/8" x 3" hole in the bedliner at each clamp location.

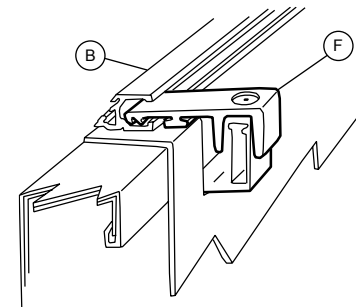

9

Inspection After Installation

1. After installation is complete, confirm proper operation and that all clamps are tightened.

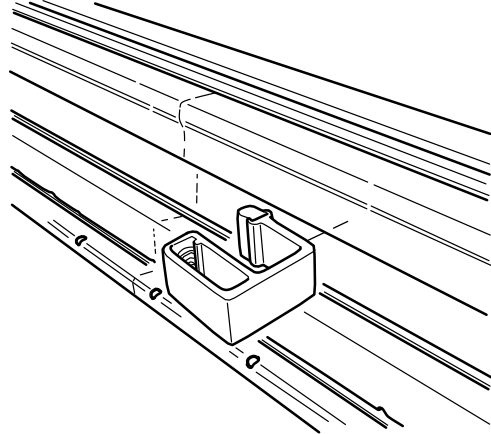

1703096
Rev.1

Installation Steps

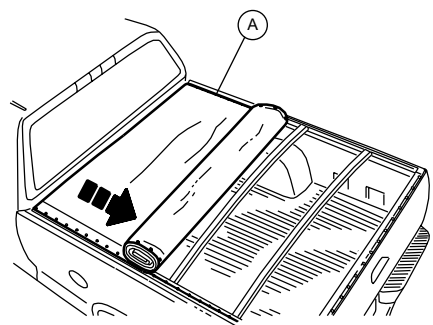

Unroll cover.

7

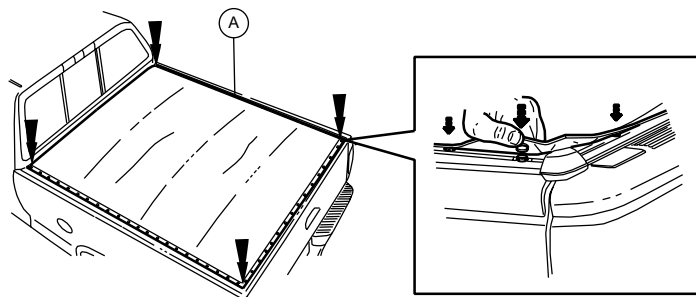

Start at corners and fasten cover to tonneau rails.

8

1703096
Rev.1

Installation Steps

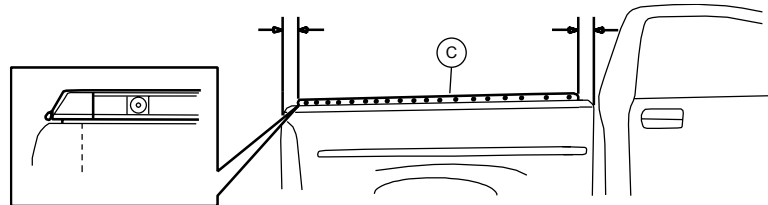

Center the frame on the truck. Next, center the side rail system from side to side.

4

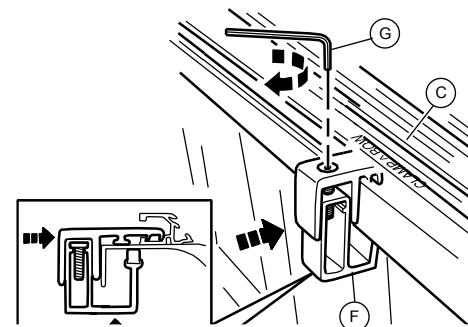

For ease of installation the side rails have been marked with the clamp locations. Place a clamp centered at each of the locations marked on the side rails.

Insert the upper clamp all the way into the side rail and tighten with the allen wrench (G) provided.

For application with bed liners refer to the bed liner instruction in Frame #9.

5

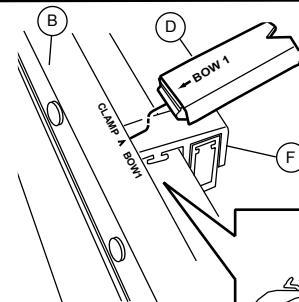

The bow rests upon the top of the clamp with each of its legs draped over the sides.

Some truck boxes are not square and require bows of different lengths. On these trucks the bows will be marked as Bow 1, Bow 2, etc. The location closest to the cab is bow 1.

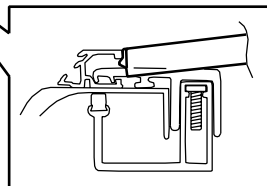

6